

INSTRUCTION MANUAL

THIS MODEL IS NOT A TOY!

THESE INSTRUCTIONS SHOULD BE READ BY A SUPERVISING ADULT

MAD SHARK RTR MINI EP F1 SPEED BOAT

ITEM NO. 8203

CONTENTS OF SET

- | | |
|--|--|
| 1) MAD SHARK RTR MINI EP F1 SPEED BOAT | 5) Boat Stand |
| 2) Transmitter | 6) 9V Dry battery (for Transmitter) |
| 3) 7.4V Power Pack | 7) 2.5mm Allen Key (For pushrod tighten) |
| 4) 2S balance charger with DC adapter | 2.0mm Allen Key (for Grub Screws) |

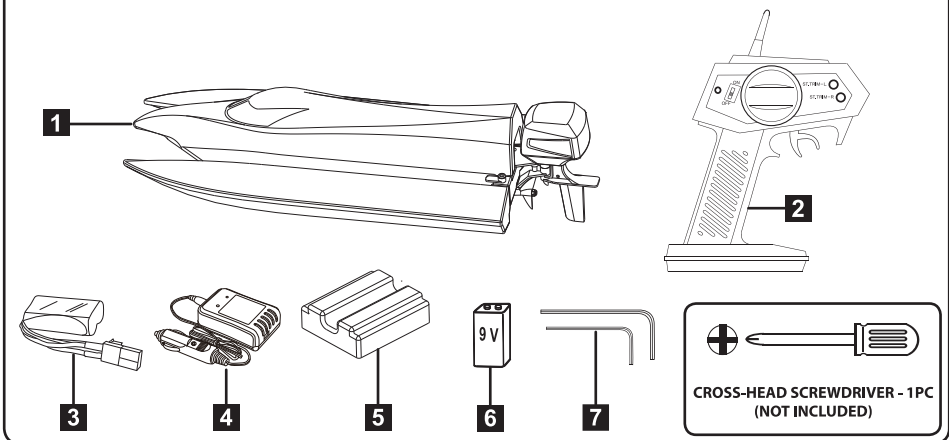

Caution for Li-Ion battery:

ESC with low voltage hard cut off at 3.2V per cell, when driving your boat, as soon as you notice boat speed slow down, that means ESC low voltage cut off effective, you should immediately drive boat back to shore in slow speed, recharge battery and race again. don't keep racing boat when ESC low voltage cut off effective, otherwise, you will allow battery over discharge, battery voltage will reach very low and won't be recharged again.

Caution:

1. Continuous running of the model will generate high heat levels, Which will lead to premature wear of the motor. Once your power pack is exhausted, we recommend that you open model's upper deck and let motor air cool for around 15 minutes before installing a fresh power pack. This action will protect motor and extend its working life.

2. Before racing your model boat, carefully check silicone tube for guarantee good water cooling system; Avoid water inlet on the bottom of hull become deformed, otherwise, water cooling system failure, this may lead to ESC burned out and motor defected.

IMPORTANT

The Mad Shark is designed for use in fresh water only. It is not designed for use in salt water!
The Mad Shark is not intended for persons under 14 years of age, unless closely supervised by an adult.

INSTALLING THE 9V DRY BATTERY IN YOUR TRANSMITTER

Always use a fresh 9V battery in the transmitter.

- 1) Ensure transmitter 'ON/OFF' switch is in the 'OFF' position.
- 2) Remove battery cover screw.
- 3) Remove battery cover by pressing down on the embossed arrow and sliding the cover as indicated.
- 4) Insert 9V battery, noting correct location (polarity + or -).
- 5) Slide battery cover back into place.
- 6) Re-fit transmitter cover screw.

NOTE 1: The Mad Shark is supplied with a start-up 9V dry cell battery. Once this battery is depleted, please replace it with another dry cell 9V battery (alkaline recommended) or fully charged 9V rechargeable battery. Remove 9V battery from the transmitter if you do not intend to use it for a period of time.

NOTE 2: When the transmitter battery (dry cell or rechargeable) is at the end of its life, it should be disposed of at an approved battery recycling centre.

DO NOT DISPOSE OF IT IN HOUSEHOLD WASTE!

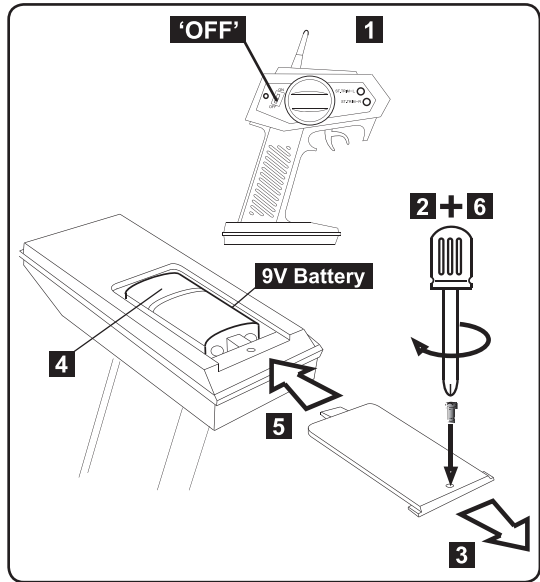

CHARGING THE 7.4V POWER PACK

- 1) Plug the DC adapter into the balance charger.
- 2) Plug the DC adapter into a DC power outlet, such as car cigarette lighter, The red light turn on means power on.
- 3) Plug the white balance plug on 7.4V power pack into the white balance charge port on balance charger, Do not force them together - they only attach one way! The green light turn on means charging.
- 3) Supplied 7.4V power pack will charge from flat in around 45 mins. Green light turn off means charging finished.
- 4) Disconnect the 7.4V power pack from the balance charger, unplug the balance charger from the car.

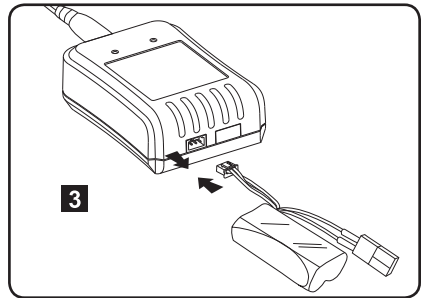
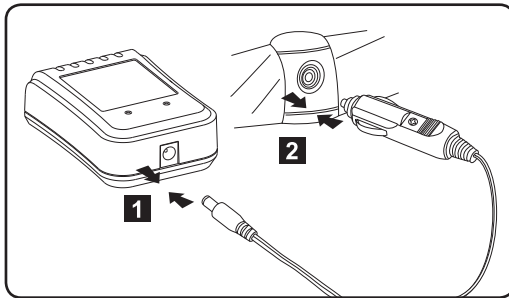

CAUTION:

- 1) The 7.4V Power Pack is not supplied pre-charged and you must charge it fully before using your Mad Shark for the first time.
- 2) The 7.4V Power Pack can be re-charged many times before it needs replacing. When the 7.4V Power Pack no longer holds a charge (is dead), it should be properly recycled.

DO NOT DISPOSE OF IT IN HOUSEHOLD WASTE!

- 3) Never leave the battery unattended during the charging process. Always keep this charger out of reach of children.
- 4) Do not attempt to disassemble the charger
- 5) Un-plug the charger from the vehicles' cigarette lighter if you do not intend to use it for a period of time

NOTE 1: The Mad Shark will typically run for around 8 minutes on a fully charged 7.4V Power Pack. As soon as you notice a drop off in speed you should bring the model back to shore or control may be lost.

NOTE 2: If you want to run your Mad Shark for extended periods, you can purchase additional 7.4V

INSTALLING THE 7.4V POWER PACK IN THE MAD SHARK

1. Switch on transmitter power, the light glows bright red.
2. firstly rotate the plastic lock underneath the boat head, then rotate the four plastic lock at the hatch as photo show to remove the hatch.

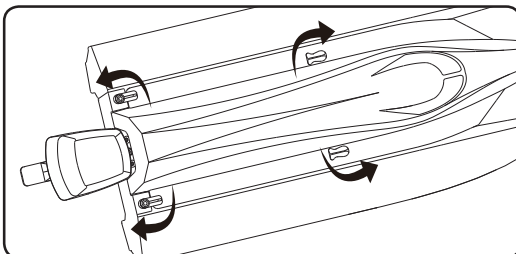
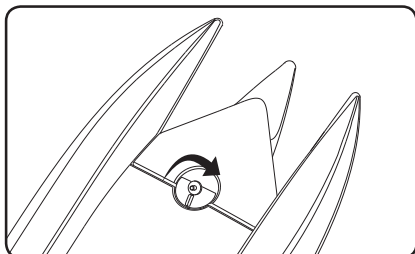

3. Place the boat hull on the polyfoam boat stand
4. Fixt the charged finished battery inside the hull with velco strap.
5. Attach battery connector to the matching connector of ESC.
6. Re-position hatch by rotating plastic locks at the hatch firstly, then rotate the plastic lock underneath the boat head.

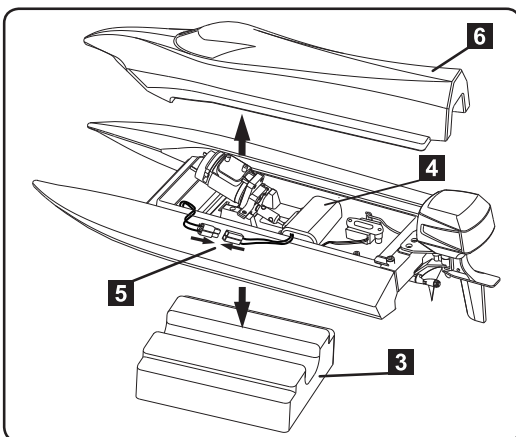

NOTE: 1. There is a water proof rubber ring placed inside the slot of hull, always make sure it's secured positioned before re-position the hatch.

TRANSMITTER/RECEIVER BINDING

The binding process effectively ties the transmitter and receiver together. Under normal circumstances, both items are supplied like this from the factory. If, however, you find that your transmitter and receiver are not bound(receiver's red LED is on), you should do the following:

- 1) Switch "ON" the transmitter.
- 2) Switch "ON" the receiver by Attaching the 7.4V power pack's connector to the matching connector in the Mad Shark boat.
- 3) Press down the "BIND" button on the receiver, the receiver's green LED will be on to indicate that binding has been successful and the receiver will now accept commands from the transmitter.

NOTE 1: During binding process, transmitter and receiver should be no more than one meter apart and no other similar devices should be within 10 meters.

NOTE 1: if the green light flashing, showing the binding failure, please do again as above indication.

HOW TO CONTROL/OPERATE YOUR MAD SHARK

1) Forward Throttle Trigger

Your Mad Shark can be driven forward by pulling the throttle trigger. Release the trigger and the Mad Shark will stop.

2) Left/Right Steering Wheel

The steering wheel controls the Mad Shark's left and right movement. Turn the wheel to the left to steer to the left. Turn the wheel to the right to steer to the right. Release the wheel to go straight.

Racing Tip: The Mad Shark is an oval racer, designed for clockwise racing, and will be less responsive to steering inputs at high speed. Decrease your speed to allow tighter turning.

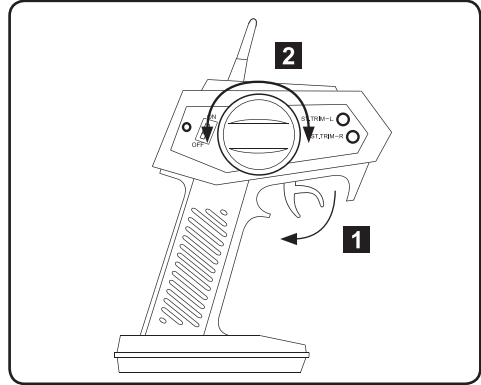

AFTER USE

- 1) When you have finished using your Mad Shark you should first switch 'OFF' the model (disconnect the 7.4V Power Pack), then switch 'OFF' your transmitter.
- 2) Remove all batteries from the transmitter and model.
- 3) Leave the Mad Shark's upper deck off to allow moisture to evaporate. Ideally, place the model in this way in a warm and dry place, like an airing cupboard, until you are sure it is dry and then store it away.
- 4) Remove the rubber ring from the slot of hull, so as to keep the rubber ring flexible for water proof effective in next time boat racing.

NOTE: If the Mad Shark begins to bob when running, it may have taken on an excessive amount of water. In this case, you should immediately return to shore, remove the upper deck and drain the water from the hull.

IF THE MAD SHARK DO NOT RUN IN A STRAIGHT LINE

If your Mad Shark do not run in a straight line when not being steered, you can adjust it by using the steering trim located on the upper right hand side of the transmitter.

- 1) Run your Mad Shark on calm water when adjusting the steering. If your model runs to the right when not being steered, press the "ST.TRIM-L" button. Re-center the model and see if this has corrected the problem. Keep making small adjustments in this way until the model runs straight.

Press the "ST.TRIM-R" button to correct if your model steers to the left without being steered in the same way as detailed above.

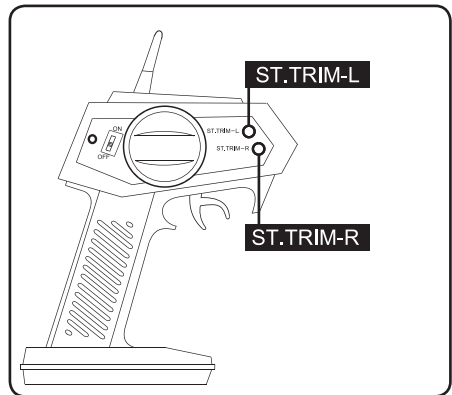

LUBRICATING DRIVE SHAFT

Lubricating the flexshaft is vital to the life of the drivetrain. The lubricant also acts as a water seal, keeping water from entering the hull through the stuffing tube. Lubricating the flexshaft, propeller shaft after every 2 or 3 times of operation.

1. Use the 2mm Allen key to loose the two grub screws of the coupler which connects the flexshaft, then slide the flexshaft w/ prop shaft out of the stuffing tube.
2. Lubricate the flexshaft w/ prop shaft with the water proof marine grease, reinstall the flexshaft w/ prop shaft in reverse order, be sure to retighten the two grub screws of coupler.

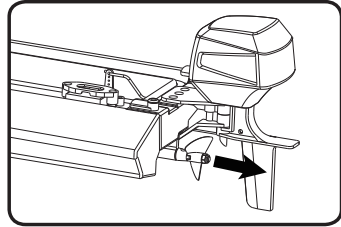
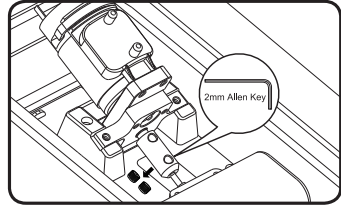

CAUTION!

Please observe the following warnings. DURING OPERATION

- The transmitter's range will vary depending on your surroundings and battery strength. Do not operate Mad Shark too far away or control will be lost.
- Ensure that all batteries are correctly installed and that the 7.4V Power Pack is fully charged.
- Do not operate your Mad Shark in areas with strong currents, in salt water or areas of water with large waves.
- Do not touch moving parts during operation, especially the propeller.
- Do not let your Mad Shark run aground, as this can cause damage.
- If you lose control of your Mad Shark, never wade into deep water or water with strong currents to retrieve it. First, hold the transmitter as high as you can to try to re-establish control. If this does not work, find another way to move closer to the model, but do not endanger yourself in the process!

GENERAL INFORMATION FOR THE SAFE OPERATION OF YOUR MAD SHARK

Please follow these simple rules to ensure safe operation and gain the maximum enjoyment from your model.

- Avoid overloading your model. Never run it in areas where its movement will be restricted, e.g. areas where there is pond weed, etc., as this can over stress the motor.
- Ensure nothing prevents the smooth running of moving parts.
- Do not run your model in confined spaces.
- Never run your model in a public space where it might upset or endanger people or wildlife.
- Immediately switch 'OFF' your model and transmitter if you see lightning or hear thunder. Never use your model in the rain.

Do not dismantle or tamper in any way with this R/C vehicle and its transmitter. The manufacturer and distributor will accept no responsibility, expressed or implied, for accidents or injuries caused as a result of disassembly, modification and/or usage against the Instructions for this product.

Tampering or modification will also invalidate the guarantee.

TROUBLE SHOOTING

Check using the chart below before returning your Mad Shark for repair as many problems can be easily solved.

PROBLEM	CAUSE	REMEDY
Model will not move	No battery in transmitter/model Battery installation is incorrect Weak battery in transmitter Weak batteries in model	Install batteries Install batteries correctly Install a fresh battery Recharge 7.4V Power Pack
No control of model	Weak battery in transmitter	Install a fresh battery
Limited radio range	Weak battery in transmitter	Install a fresh battery

SPARE PARTS

<i>PART NO.</i>	<i>DESCRIPTION</i>
82014	390 motor
82019	7.4V 800mAH Li-Ion Pack
82050	2.4GHz Transmitter-Mad shark brushed
82051	2.4GHz RX,ESC,Servo set-Mad shark brushed
82052	Mad shark Deck(yellow) & gasket
82053	Flex Shaft set for Mad shark
82054	Scale Outboard engine and rudder set
82055	Gear box set
82056	Two Blade Nylon Propeller (PK2)
82057	2S balance charger(800mA)and DC adapter
82058	deck plastic lock set
82059	Aluminium Alloy Coupler w/3 screws



FCC WARNING: Changes or modifications not expressly approved by the party responsible for compliance could avoid the user's authority to operate the equipment.