



www.estesrockets.com

Estes-Cox Corp.
1295 H Street, PO Box 227
Penrose, CO 81240-0227

Printed in China

SUPERNEON™

FLYING MODEL ROCKET KIT INSTRUCTIONS

KEEP FOR FUTURE REFERENCE.

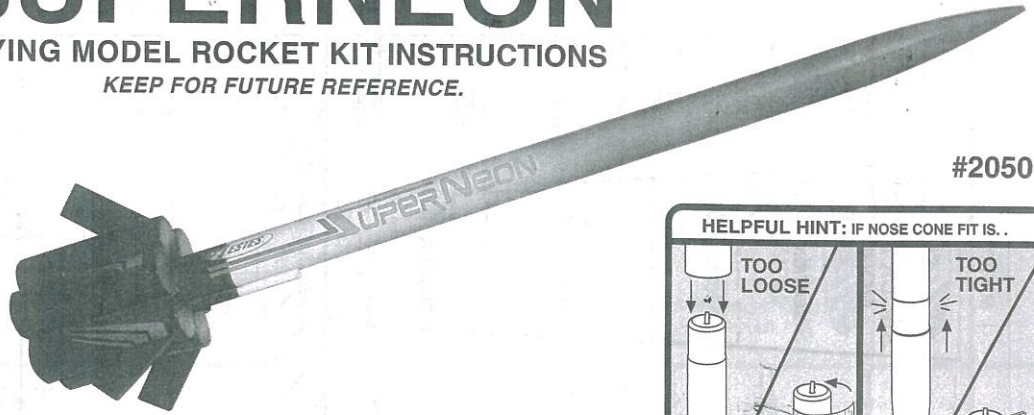

#2050

ASSEMBLY TIP

Read all instructions before beginning work on your model. Make sure you have all parts and supplies.

TEST-FIT ALL PARTS TOGETHER BEFORE APPLYING ANY GLUE. If any parts don't fit properly, sand as required for precision assembly.

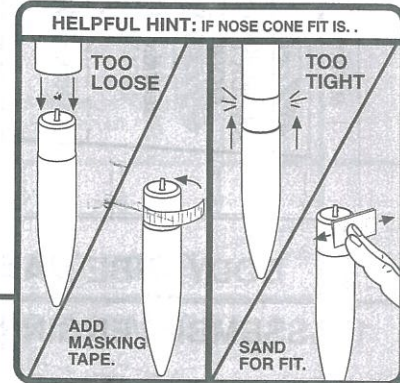

PARTS

Locate the parts shown below and lay them out on the table in front of you. **DO NOT USE THIS DRAWING TO ASSEMBLE YOUR ROCKET.**

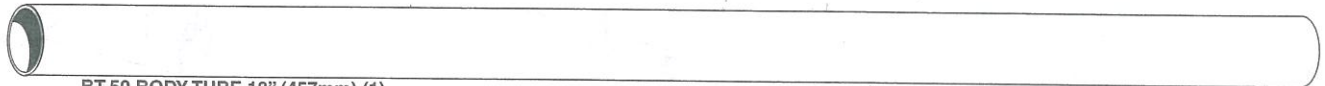

BT-50 BODY TUBE 18" (457mm) (1) (30352)

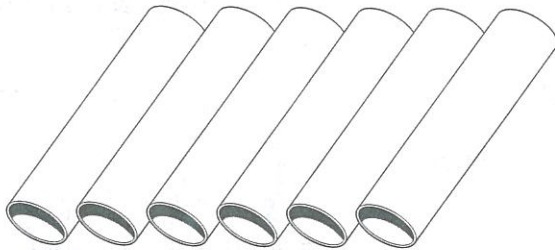

BT-50 FIN TUBES 3-1/2" (89 mm) (6) (30357)

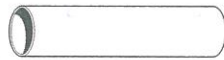

BT-20 ENGINE MOUNT TUBE 2-3/4" (69.9 mm) (1) (30408)

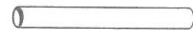

LL-2B LAUNCH LUG 1/8" (3 mm) x 2-3/8" (60 mm) (1) (38178)



PNC-50YR NOSE CONE (1) (72604)

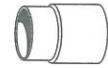

NOSE CONE INSERT (1) (72605)



AR520 GREEN ENGINE BLOCK (1) (30162-2)



RUBBER SHOCK CORD 1/8" X 24" (3 mm X 610 mm) (1) (38367)



2050L ADAPTER RING GREEN (1) (30165-2)



EH-2A ENGINE HOOK (1) (35021)

DECAL SHEET (1) (37491)

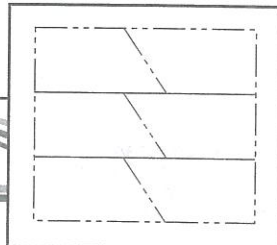
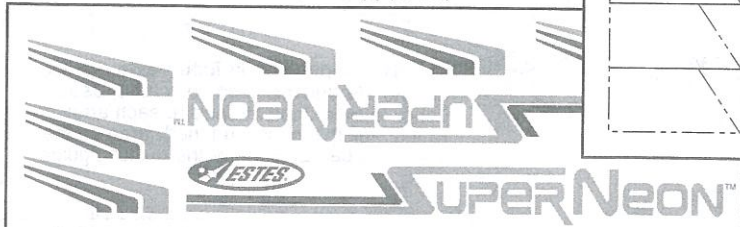

LASER CUT BALSA FIN SHEET (1) (32784)

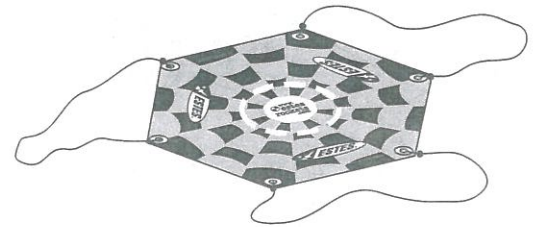

ASSEMBLED PARACHUTE 12" (305 mm) (1) (35801)

SUPPLIES

In addition to the parts included in the kit you will also need:



SCISSORS



PENCIL



RULER



FINE SAND PAPER (#220-400 GRIT)



CARPENTER'S GLUE



MODELING KNIFE



PLASTIC CEMENT



MASKING TAPE



SPRAY PRIMER (WHITE)



SPRAY PAINT WHITE, NEON BLUE, NEON PURPLE



SPRAY CLEAR COAT (OPTIONAL)



RUBBER BANDS

TUBE MARKING GUIDES AND SHOCK CORD MOUNT (Make a copy if you want to keep instructions.)

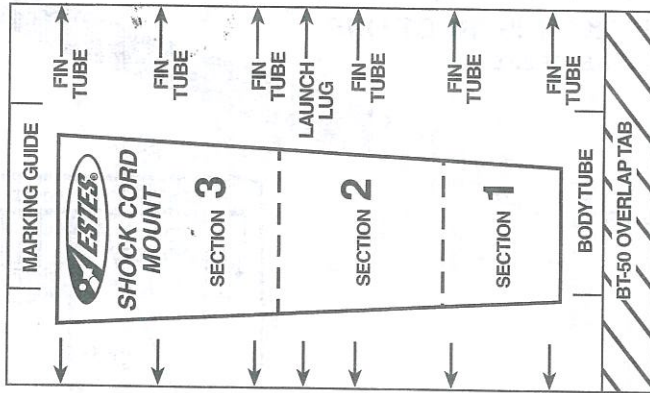

BODY TUBE MARKING GUIDE

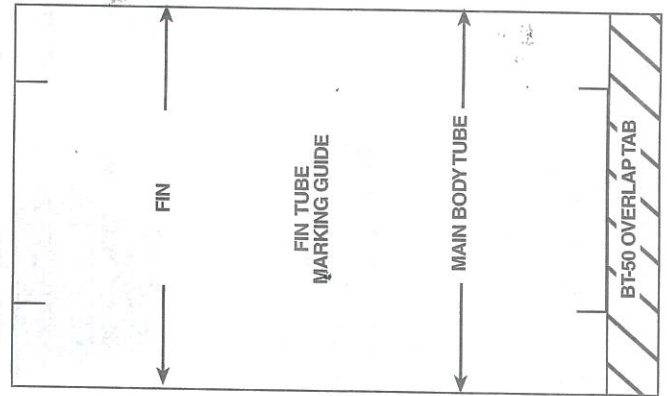

FIN TUBE MARKING GUIDE

1. ASSEMBLE ENGINE MOUNT

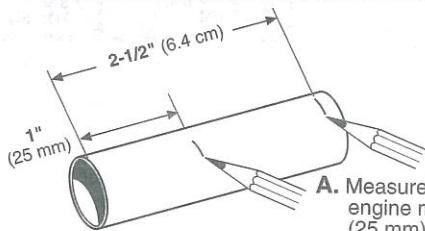

A. Measure and mark engine mount tube at 1" (25 mm) and 2-1/2" (64 mm).

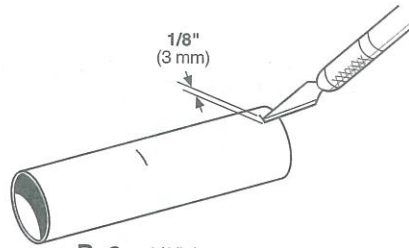

B. Cut 1/8" (3 mm) slit at 2-1/2" (64 mm) mark.

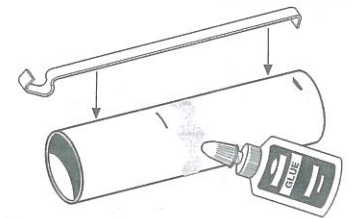

C. Apply glue around tube just above the 1" (25 mm) mark. Position and insert engine hook into slit as shown.

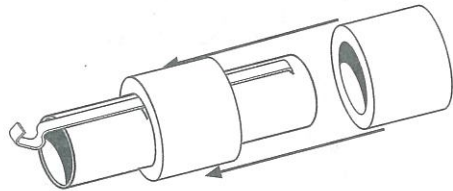

D. Push adapter ring onto engine mount tube to the 1" (25 mm) mark.

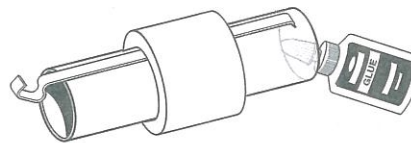

E. Apply glue inside engine mount tube.

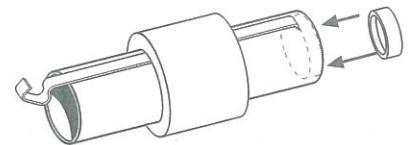

F. Insert engine block ring. Let assembly dry completely.

2. MARK FIN AND LAUNCH LUG LINES

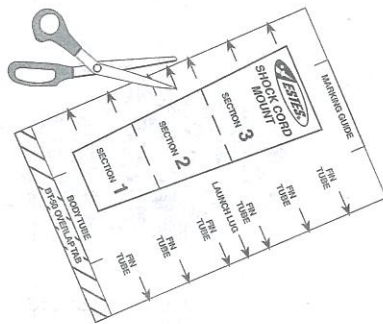

A. Cut out the two tube marking guides from this page. Do not cut out the shock cord mount at this time.

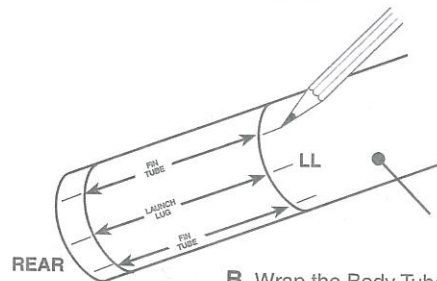

B. Wrap the Body Tube marking guide around the main body tube. Use a pencil to mark tube at each arrow. At the launch lug mark write on the tube LL. Remove the marking guide.

C. Wrap the Fin Tube marking guide around one of the fin tubes. Use a pencil to mark the tube at each arrow point, then remove the guide. Repeat this step for the remaining five fin tubes.

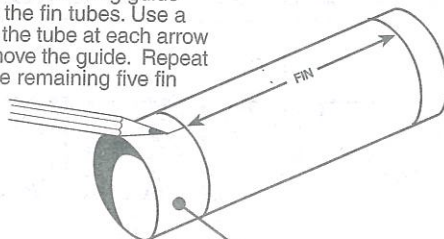

FIN TUBE

D. Hold the body tube against a door frame. Align the LL pair of marks on the body tube with the door stop then draw a light pencil line the length of the body tube. Align the remaining marks with the stop and draw a light pencil line 3" (76mm) from the end of the tube. Repeat for the fin tubes drawing a light pencil line the entire length of the tube a each pair of marks.

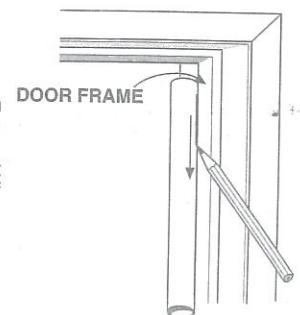

3. PREPARE FINs

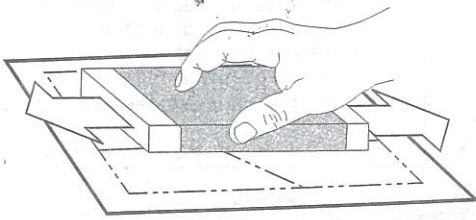

A. Sand both sides of the laser cut balsa sheet with fine sand paper.

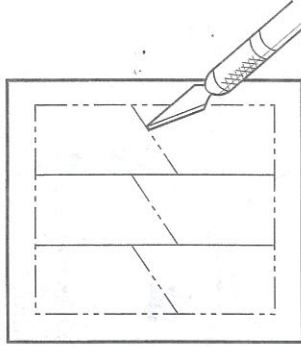

B. Cut fins free with modeling knife.

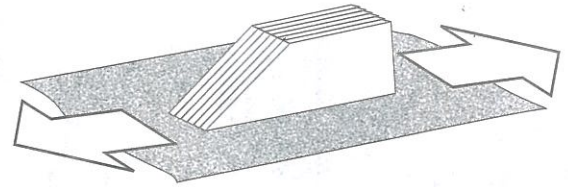

C. Stack fins together and sand edges smooth.

4. INSTALL ENGINE MOUNT

A. Use a piece of scrap balsa to smear glue inside body tube 1-1/2" (35 mm) from rear.

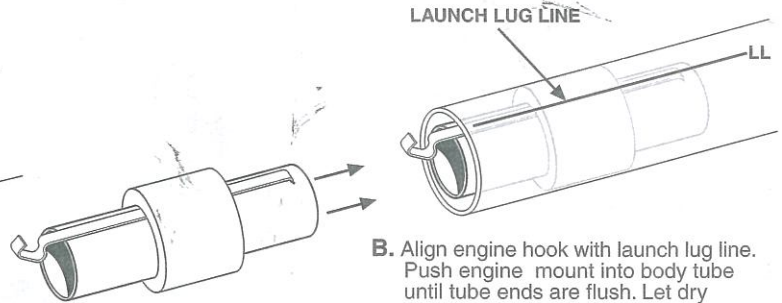
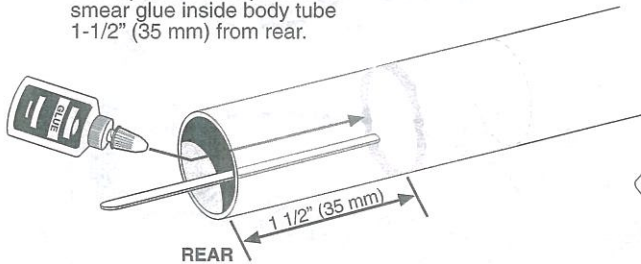

B. Align engine hook with launch lug line. Push engine mount into body tube until tube ends are flush. Let dry completely.

5. ATTACH FIN TUBES

A. Apply glue to body tube alignment line. Align with fin tube alignment line. Repeat for remaining fin tubes.

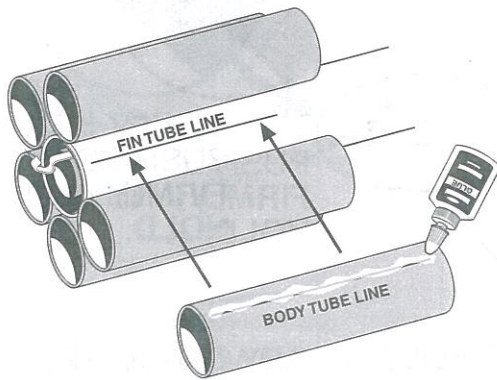

B. Adjust fin tubes to project straight along body tube and flush to rear of body.

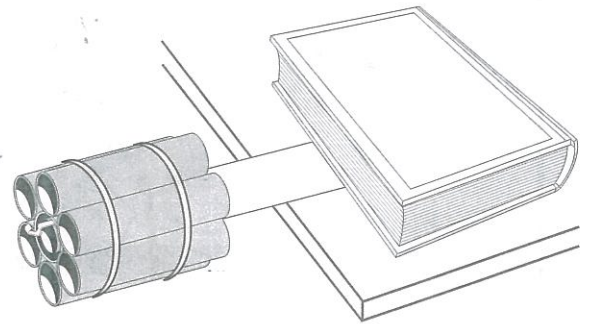
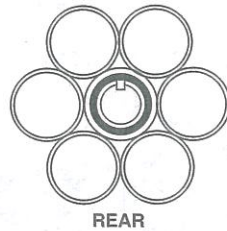

C. Secure fin tubes with rubber bands making sure not to crush tubes. Support rocket as shown until glue dries completely.

NOTE: TUBES MUST BE ATTACHED CORRECTLY FOR A STABLE FLIGHT.

6. ATTACH FINs

A. Mark across each fin tube line with a line 1/8" (3 mm) from front of each fin tube.

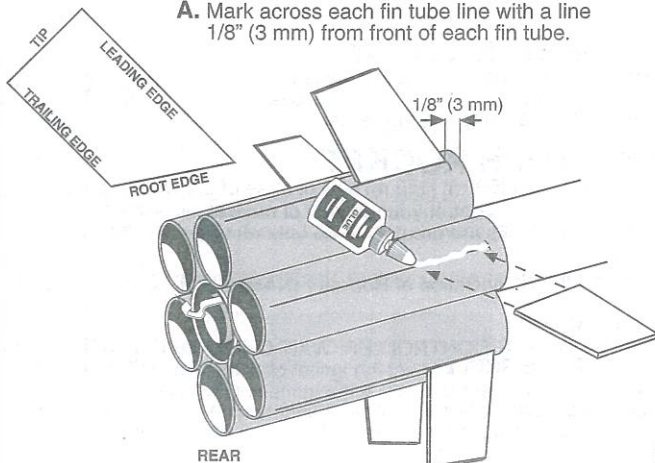

B. One fin at a time, apply a thin line of glue to the root edge and rub it into the balsa with a finger tip. Allow the glue to dry completely. Then one fin at a time, apply a line of glue along the root edge, position the leading edge of the fin at the cross mark, and attach the fin along the alignment line.

C. Using the illustration for reference, adjust each fin as necessary for perfect alignment before the glue sets. Allow all glue to dry completely.

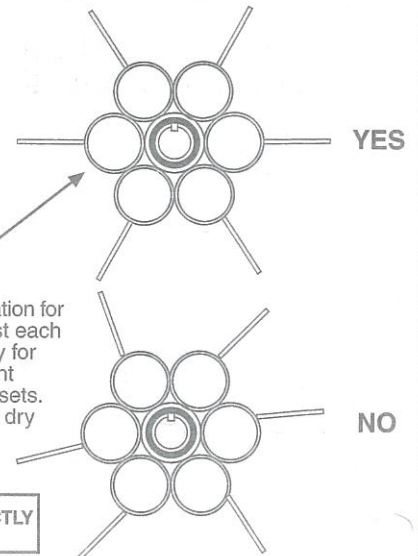

NOTE: FINs MUST BE ATTACHED CORRECTLY FOR A STABLE FLIGHT.

7. ATTACH LAUNCH LUG AND APPLY FILLETS

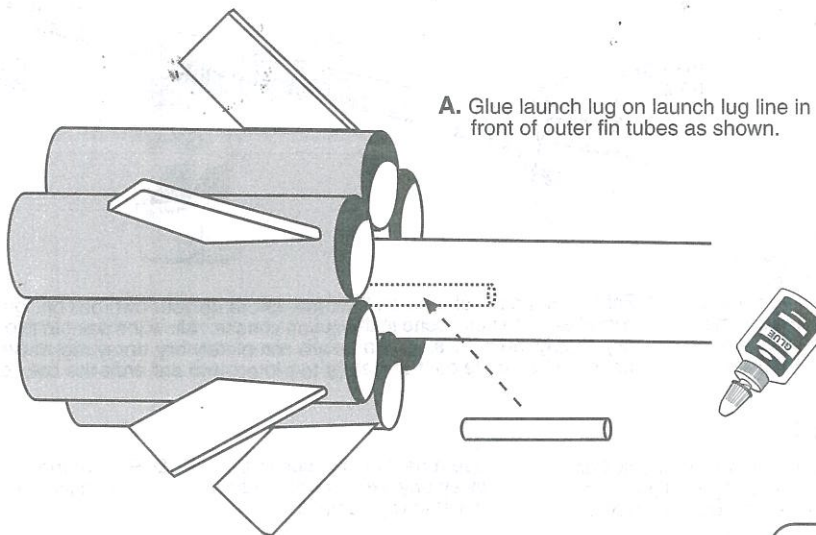

LAUNCH LUG CENTERED BETWEEN OUTER TUBES

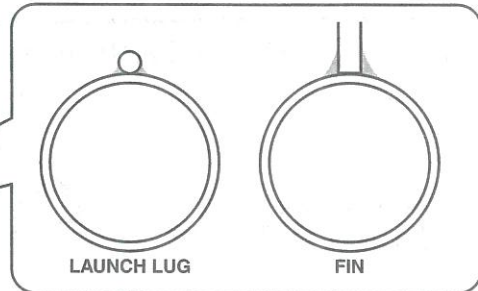
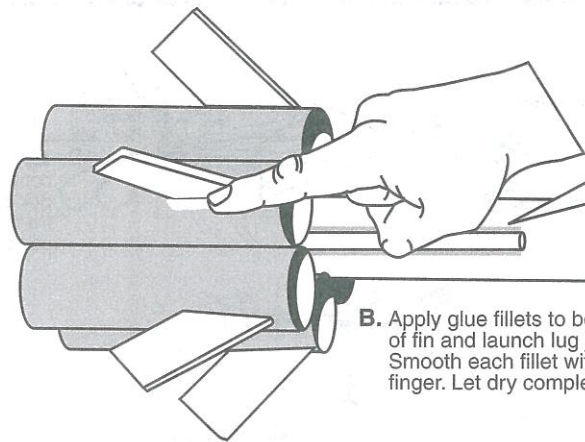
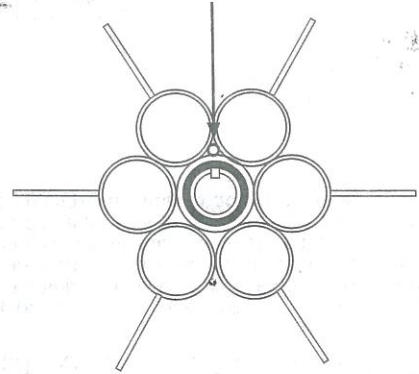

GLUE FILLETS

8. INSTALL SHOCK CORD

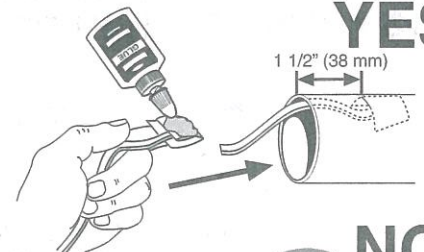
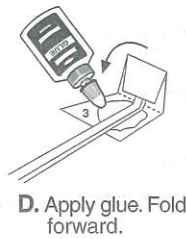
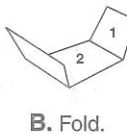
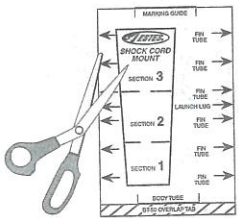

YES

1 1/2" (38 mm)

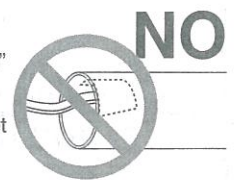

9. ASSEMBLE NOSE CONE

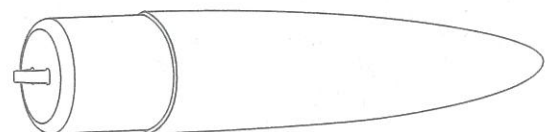
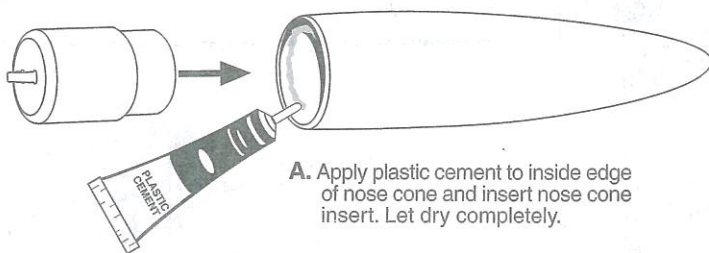

10. FINISHING YOUR ROCKET

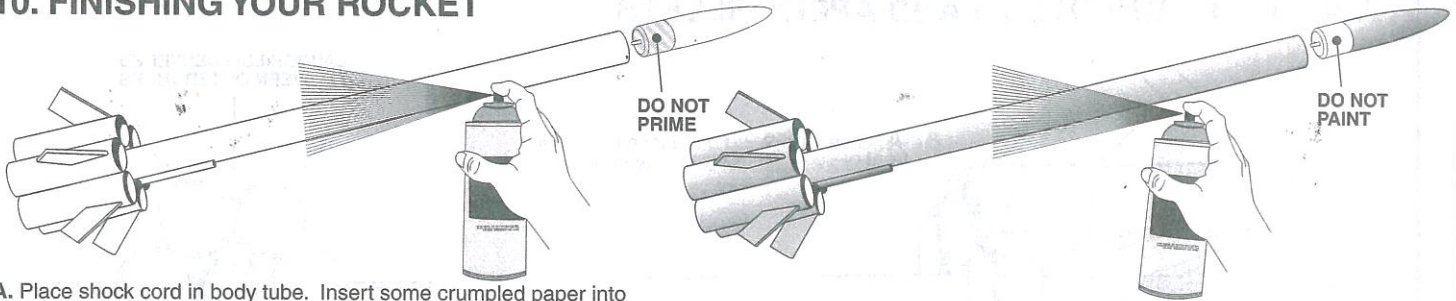

A. Place shock cord in body tube. Insert some crumpled paper into the motor mount and rocket body tube to protect it from primer & paint. Wrap a piece of masking around the adapter of the nose cone to protect it from paint. Apply two or three light coats of spray primer to the body tube and fins. Allow the primer to dry between coats. Then use 400 grit sandpaper to lightly sand the entire model for a smooth finish.

B. Follow the paint scheme on the package, or create your own design. Paint the rocket and the nose cone in the colors you choose. Allow the paint to thoroughly dry. Apply the decals. When decals are completely dry, spray rocket and nose cone with a single coat of clear gloss to protect and enhance the colors.

TO APPLY WATERSLIDE DECALS:

A. Cut out an individual section of the decal and dip in lukewarm water for about 10 seconds (one at a time).

B. When the decal slides freely from the backing paper, slip it onto the model and position in place.

C. Use a napkin or tissue to blot away any excess water. Allow decal to dry completely.

D. Repeat the process for remaining decals.

11. ATTACH PARACHUTE AND NOSE CONE

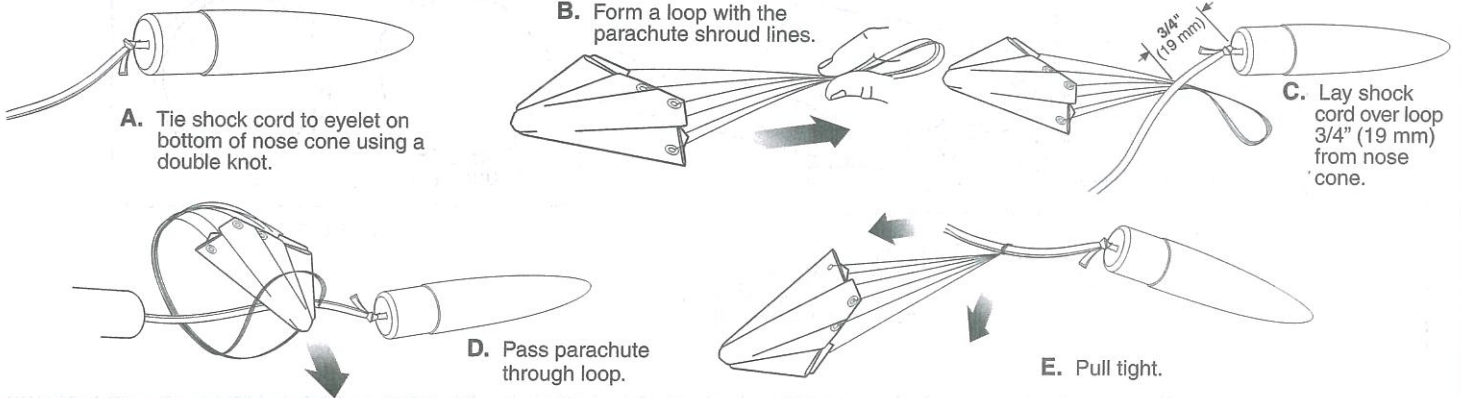

A. Tie shock cord to eyelet on bottom of nose cone using a double knot.

B. Form a loop with the parachute shroud lines.

C. Lay shock cord over loop 3/4" (19 mm) from nose cone.

D. Pass parachute through loop.

E. Pull tight.

12. PREPARE FLIGHT RECOVERY

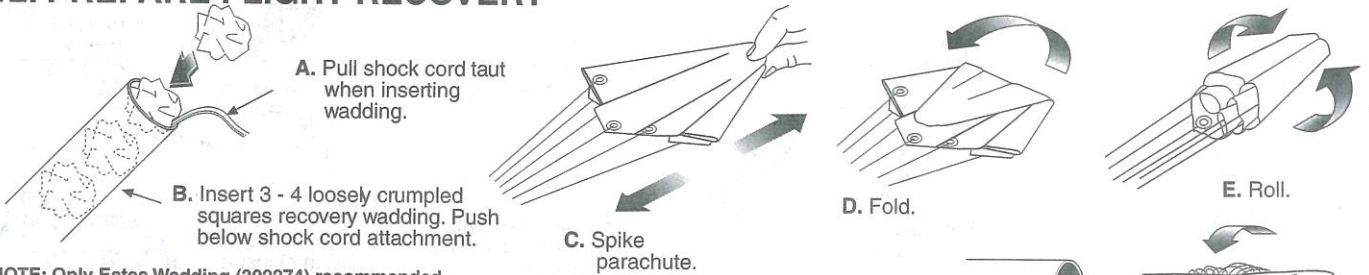

A. Pull shock cord taut when inserting wadding.

B. Insert 3 - 4 loosely crumpled squares recovery wadding. Push below shock cord attachment.

C. Spike parachute.

D. Fold.

E. Roll.

NOTE: Only Estes Wadding (302274) recommended.

13. PREPARE ENGINE

⚠ WARNING: FLAMMABLE

To avoid serious injury, read instructions & NAR Safety Code included with engines.

PREPARE ENGINE ONLY WHEN YOU ARE OUTSIDE AT THE LAUNCH SITE PREPARING TO LAUNCH!

If you do not use your prepared engine, remove the igniter before storing engine.

A. Separate igniter and igniter plug.

B. Insert igniter.

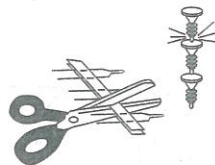

IGNITER MUST TOUCH PROPELLANT!

C. Insert plug.

D. Push down.

E. Gently bend igniters to form leads as shown.

D. Insert engine into rocket.

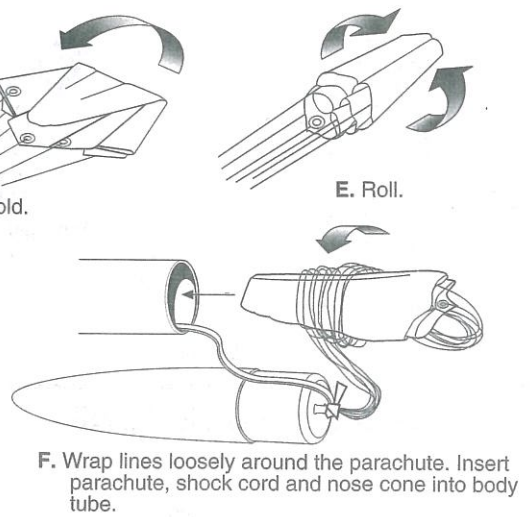

F. Wrap lines loosely around the parachute. Insert parachute, shock cord and nose cone into body tube.

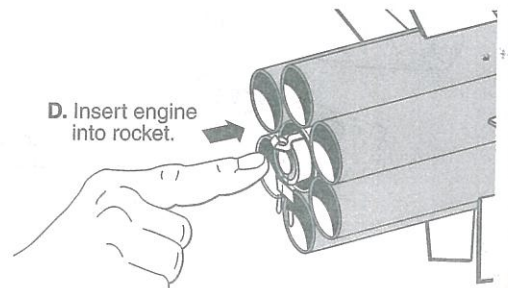

COUNTDOWN AND LAUNCH

ESTES LAUNCH SUPPLIES

- (Sold Separately)
- Porta Pad® II Launch Pad
 - Electron Beam® Launch Controller
 - Recovery Wadding (302274)
 - Igniters (with engines)
 - Igniter Plugs (with engines)
 - Estes Engines: A8-3, B4-4, B6-4, C6-5

KEY ALWAYS OUT UNTIL FINAL COUNTDOWN!

1...

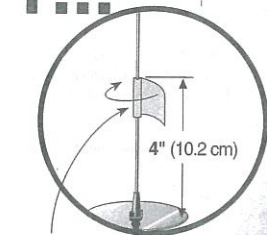

MASKING TAPE

2...



3...

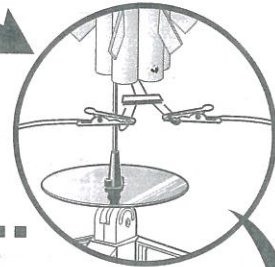

4...

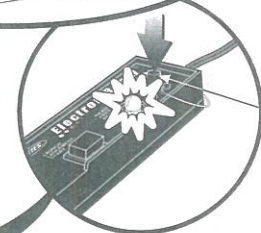

KEY

INSERT KEY. PUSH DOWN FIRMLY AND HOLD.

5...



WHILE HOLDING KEY DOWN, PRESS LAUNCH BUTTON UNTIL LIFTOFF!

PRECAUTIONS



NAR Safety Code



NO DRY GRASS OR WEEDS



PRE-LAUNCH CHECK

For safety, never launch a damaged rocket. Check the rocket's body, nose cone and fins. Also, check the engine mount, recovery system and launch lug(s). Repair any damage before launching the rocket.

FLYING YOUR ROCKET

Choose a large field (500 ft. [153 m] square) free of dry weeds and brown grass. The larger the launch area, the better your chance of recovering your rocket. Football fields and playgrounds are great. Launch only with little or no wind and good visibility.

Always follow the National Association of Rocketry (NAR) SAFETY CODE.

MISFIRES

TAKE THE KEY OUT OF THE CONTROLLER. WAIT ONE MINUTE BEFORE GOING NEAR THE ROCKET! Disconnect the igniter clips and remove the engine. Take the plug and igniter out of the engine. If the igniter has burned, it worked but did not ignite the engine because it was not touching the propellant inside the engine. Put a new igniter all the way inside the engine without bending it. Push the plug in place. Repeat the steps under Countdown and Launch.