

Hawker Sea Fury 400 ARF

Assembly Manual

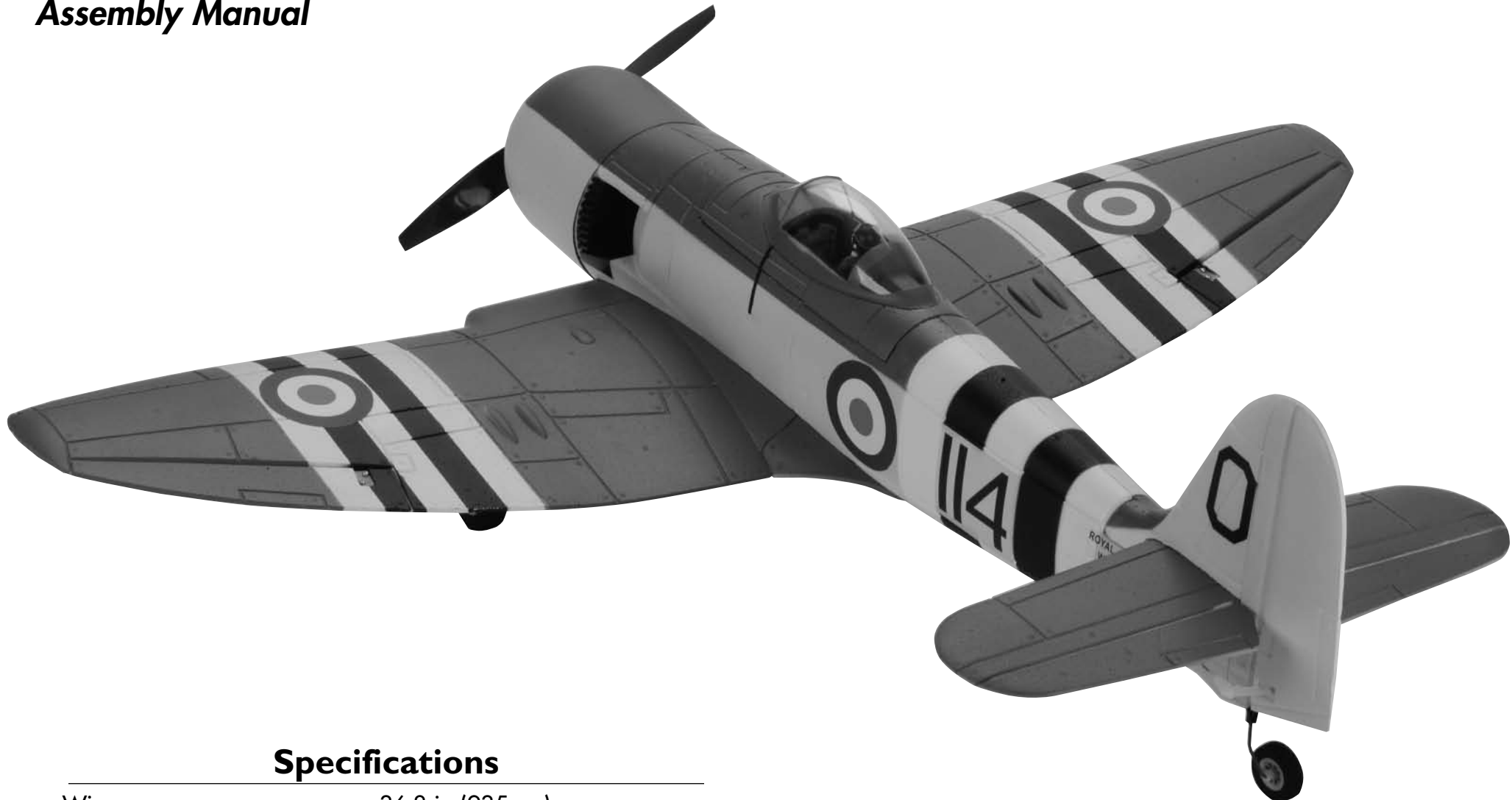

Specifications

Wingspan:	36.8 in (935mm)
Length:	33.3 in (845mm)
Wing Area:	267.8 sq in (17.4 sq dm)
Weight w/ Battery:	25-30 oz (710-850 kg)
Weight w/o Battery:	20-25 oz (565-710 kg)

E-flite[®]
ADVANCING ELECTRIC FLIGHT

Table of Contents

Specifications	1
Introduction.....	2
Using the Manual.....	3
Contents of Kit/Parts Layout.....	3
Required Radio Equipment.....	3
Important Information About Motor Selection	4
Sport Brushless Outrunner Setup	4
High Power Brushless Outrunner Setup	4
Optional Accessories	4
Required Tools and Adhesives	4
Notes Regarding Servos and ESC	5
Note on Lithium Polymer Batteries	5
Warning	5
Warranty Information	5
Safety, Precautions, and Warnings	7
Fixed Gear Installation.....	8
Retract Installation	9
Aileron Servo Installation	12
Main Wheel Installation.....	16
Motor and Cowling Installation	17
Radio Installation - Fuselage	23
Tail Gear Installation - Fixed Rudder	24
Optional Operable Rudder	25
Stabilizer/Elevator Installation.....	29
Final Assembly.....	33
Control Throws.....	36
Center of Gravity	37
Range Test Your Radio	37
Instructions for Disposal of WEEE by Users in the European Union	37
Preflight.....	38
Flying Your Hawker Sea Fury ARF.....	38
2008 Official AMA National Model Aircraft Safety Code ...	39

Introduction

The Hawker Sea Fury was a British fighter aircraft developed by Hawker for the Royal Navy during the Second World War. The Sea Fury was designed as a single piston engine, propeller driven fighter for aircraft carrier take-offs and landings. It is known for being one of the fastest single piston engine aircraft ever built and while it arrived too late for service during WWII, it did serve admirably during the Korean War. The well known historical event for the Hawker Sea Fury was on August 9, 1952, when Lieutenant Peter "Hoagy" Carmichael of the Royal Navy shot down a MiG-15 jet-powered fighter in combat. This was one of very few piston-engine powered fighters to successfully engage a turbine-powered adversary. E-flite has produced the Hawker Sea Fury 400 ARF as an EPS injection-molded foam model to offer lightweight, durable and easily repairable construction. The scale detail is complete with accurately molded panel lines and a factory painted and installed cockpit, pilot figure and canopy. For additional scale detail, optional factory finished rockets and retractable landing gear can also be installed. This 400-sized aircraft boasts factory installed spars, hinges, and control horns. You have the option to select between the included fixed landing gear or retractable landing gear. All of the parts are included for either of the landing gear options.

The E-flite Hawker Sea Fury has an elliptical shaped wing that offers gentle flight characteristics not typically found in this class of model. The bolt-on wing is easily removed for transportability and access to on-board electronics. Other electronics are easily accessible through the magnetic battery hatch. The Sea Fury has lightly loaded flight characteristics resulting in smooth handling and ease of flight. This warbird gives the modeler different power options with the factory installed stick motor mount. This model is perfect for mounting 400-480 size outrunner brushless motors. The model is matched with popular sized batteries for excellent power and flight duration potential. This warbird boasts scale details, a high level of prefabrication, and flight characteristics that are unmatched by the competition.

Using the Manual

This manual is divided into sections to help make assembly easier to understand, and to provide breaks between each major section. In addition, check boxes have been placed next to each step to keep track of its completion. Steps with a single circle (○) are performed once, while steps with two circles (○○) indicate that the step will require repeating, such as for a right or left wing panel, two servos, etc.

Remember to take your time and follow the directions.

Contents of Kit/Parts Layout

Large Parts:

EFL6055	Cowling
EFL6059	Spinner
EFL6060	Retract Set
EFL6061	Straight Wire Struts for Retracts
EFL6062	Bent Wire Struts for Fixed Gear
EFL6063	Fixed Landing Gear Set

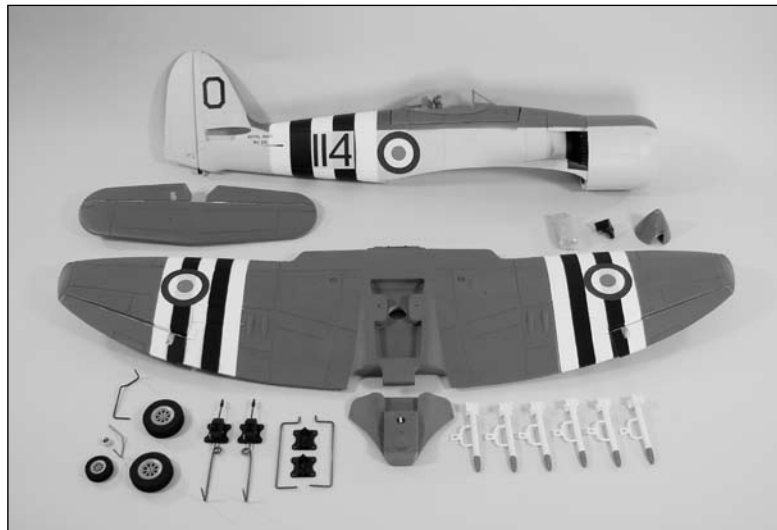

Required Radio Equipment

You will need a minimum 3-channel transmitter, crystals, receiver, and three sub-micro servos. You can choose to purchase a complete radio system. If you are using an existing transmitter, just purchase the other required equipment separately. We recommend the crystal-free, interference-free Spektrum™ DX6i 2.4GHz DSM® 6-channel system. If using your own transmitter, we recommend the E-flite® S75 Sub-Micro Servos.

If you own the Spektrum DX6i radio, just add the AR6100E DSM2™ 6-channel receiver and three (to six) of our E-flite S75 Sub-Micro Servos.

Complete Radio System

SPM6600 DX6i DSM 6CH system

Or Purchase Separately

JRPR720UL UltraLite 7-Channel ScanSelect™
FM Receiver (72MHz)
JRP790UL UltraLite 7-Channel ScanSelect
PCM Receiver (72MHz)

Or

SPMAR6100E AR6100E DSM2 6-Channel Receiver
UltraLite (for DX6i on DX7)

And

EFLRS75 7.5-Gram Sub-Micro Servo (3–6)
EFLREX6L 6-inch Servo Extension, Lightweight (3)
EFLREX9L 9-inch Servo Extension, Lightweight (2)
(Optional Retracts)
EFLRYH3 3-inch Y-Harness, Lightweight
(2 required without computer radio)

Important Information About Motor Selection

We recommend the E-flite Park 450 Brushless Outrunner Motor, 890Kv (EFLM1400) for sport performance or the E-flite Park 480 Brushless Outrunner Motor, 1020Kv (EFLM1505) for maximum performance.

Sport Brushless Outrunner Setup

EFLM1400	Park 450 Brushless Outrunner Motor, 890Kv
EFLA1025	25A Pro Brushless ESC with 4 servos or less or 40A Pro Switch-Mode BEC Brushless ESC (EFLA1040) with 5+ servos
EFLB21003S	E-flite 3S 11.1V 2100mAh 20C Li-Po or Thunder Power 3S 11.1V 2200mAh 25C eXtreme V2 Li-Po (THP22003SXV)
EFLAEC311	EC3 Extension Lead w/6" Wire, 16GA

High Power Brushless Outrunner Setup

EFLM1505	Park 480 Brushless Outrunner Motor, 1020Kv
EFLA1025	25A Pro Brushless ESC with 4 servos or less or 40A Pro Switch-Mode BEC Brushless ESC (EFLA1040) with 5+ servos
EFLB21003S	E-flite 3S 11.1V 2100mAh 20C Li-Po or Thunder Power 3S 11.1V 2200mAh 25C eXtreme V2 Li-Po (THP22003SXV)
EFLAEC311	EC3 Extension Lead w/6" Wire, 16GA

Optional Accessories

EFLA110	Power Meter
EFLC3005	Celectra™ 1- to 3-Cell Li-Po Charger
EFLC505	Intelligent 1- to 5-Cell Balancing Charger

Required Tools and Adhesives

Tools & Equipment

EFLA250 Park Flyer Tool Assortment, 5-piece

Or Purchase Separately

EFLA257 Screwdriver, #1 and #2 Phillips (or included with EFLA250)

Pin drill

Drill bit: 1/16-inch (1.5mm), 1/8-inch (3mm)

Razor saw

Hex wrench: 1.5mm

Felt-tipped pen

Hobby knife w/new #11 blades

Phillips screwdriver: #00, #0, #1

Ruler

Sandpaper

Foam-safe CA

Notes Regarding Servos and ESC

WARNING: Use of servos other than those we recommend may overload the BEC of the recommended Electronic Speed Control (ESC). We suggest the use of only the servos we recommend when utilizing the recommended ESC's BEC, or the use of a separate BEC (like the UBEC) or receiver battery pack when using other servos.

Note on Lithium Polymer Batteries



Lithium Polymer batteries are significantly more volatile than alkaline or Ni-Cd/Ni-MH batteries used in RC applications. All manufacturer's instructions and warnings must be followed closely. Mishandling of Li-Po batteries can result in fire. Always follow the manufacturer's instructions when disposing of Lithium Polymer batteries.

Warning

An RC aircraft is not a toy! If misused, it can cause serious bodily harm and damage to property. Fly only in open areas, preferably at AMA (Academy of Model Aeronautics) approved flying sites, following all instructions included with your radio.

Keep loose items that can get entangled in the propeller away from the prop, including loose clothing, or other objects such as pencils and screwdrivers. Especially keep your hands away from the propeller.

Warranty Information

Warranty Period

Horizon Hobby, Inc., (Horizon) warrants that the Products purchased (the "Product") will be free from defects in materials and workmanship at the date of purchase by the Purchaser.

Limited Warranty

(a) This warranty is limited to the original Purchaser ("Purchaser") and is not transferable. REPAIR OR REPLACEMENT AS PROVIDED UNDER THIS WARRANTY IS THE EXCLUSIVE REMEDY OF THE PURCHASER. This warranty covers only those Products purchased from an authorized Horizon dealer. Third party transactions are not covered by this warranty. Proof of purchase is required for warranty claims. Further, Horizon reserves the right to change or modify this warranty without notice and disclaims all other warranties, express or implied.

(b) Limitations- HORIZON MAKES NO WARRANTY OR REPRESENTATION, EXPRESS OR IMPLIED, ABOUT NON-INFRINGEMENT, MERCHANTABILITY OR FITNESS FOR A PARTICULAR PURPOSE OF THE PRODUCT. THE PURCHASER ACKNOWLEDGES THAT THEY ALONE HAVE DETERMINED THAT THE PRODUCT WILL SUITABLY MEET THE REQUIREMENTS OF THE PURCHASER'S INTENDED USE.

(c) Purchaser Remedy- Horizon's sole obligation hereunder shall be that Horizon will, at its option, (i) repair or (ii) replace, any Product determined by Horizon to be defective. In the event of a defect, these are the Purchaser's exclusive remedies. Horizon reserves the right to inspect any and all equipment involved in a warranty claim. Repair or replacement decisions are at the sole discretion of Horizon. This warranty does not cover cosmetic damage or damage due to acts of God, accident, misuse, abuse, negligence, commercial use, or modification of or to any part of the Product. This warranty does not cover damage due to improper installation, operation, maintenance, or attempted repair by anyone other than Horizon. Return of any goods by Purchaser must be approved in writing by Horizon before shipment.

Damage Limits

HORIZON SHALL NOT BE LIABLE FOR SPECIAL, INDIRECT OR CONSEQUENTIAL DAMAGES, LOSS OF PROFITS OR PRODUCTION OR COMMERCIAL LOSS IN ANY WAY CONNECTED WITH THE PRODUCT, WHETHER SUCH CLAIM IS BASED IN CONTRACT, WARRANTY, NEGLIGENCE, OR STRICT LIABILITY. Further, in no event shall the liability of Horizon exceed the individual price of the Product on which liability is asserted. As Horizon has no control over use, setup, final assembly, modification or misuse, no liability shall be assumed nor accepted for any resulting damage or injury. By the act of use, setup or assembly, the user accepts all resulting liability.

If you as the Purchaser or user are not prepared to accept the liability associated with the use of this Product, you are advised to return this Product immediately in new and unused condition to the place of purchase.

Law: These Terms are governed by Illinois law (without regard to conflict of law principals).

Safety Precautions

This is a sophisticated hobby Product and not a toy. It must be operated with caution and common sense and requires some basic mechanical ability. Failure to operate this Product in a safe and responsible manner could result in injury or damage to the Product or other property. This Product is not intended for use by children without direct adult supervision. The Product manual contains instructions for safety, operation and maintenance. It is essential to read and follow all the instructions and warnings in the manual, prior to assembly, setup or use, in order to operate correctly and avoid damage or injury.

Questions, Assistance, and Repairs

Your local hobby store and/or place of purchase cannot provide warranty support or repair. Once assembly, setup or use of the Product has been started, you must contact Horizon directly. This will enable Horizon to better answer your questions and service you in the event that you may need any assistance. For questions or assistance, please direct your email to productsupport@horizonhobby.com, or call 877.504.0233 toll free to speak to a service technician.

Inspection or Repairs

If this Product needs to be inspected or repaired, please call for a Return Merchandise Authorization (RMA). Pack the Product securely using a shipping carton. Please note that original boxes may be included, but are not designed to withstand the rigors of shipping without additional protection. Ship via a carrier that provides tracking and insurance for lost or damaged parcels, as **Horizon is not responsible for merchandise until it arrives and is accepted at our facility**. A Service Repair Request is available at www.horizonhobby.com on the "Support" tab. If you do not have internet access, please include a letter with your complete name, street address, email address and phone number where you can be reached during business days, your RMA number, a list of the included items, method of payment for any non-warranty expenses and a brief summary of the problem. Your original sales receipt must also be included for warranty consideration. Be sure your name, address, and RMA number are clearly written on the outside of the shipping carton.

Warranty Inspection and Repairs

To receive warranty service, you must include your original sales receipt verifying the proof-of-purchase date. Provided warranty conditions have been met, your Product will be repaired or replaced free of charge. Repair or replacement decisions are at the sole discretion of Horizon Hobby.

Non-Warranty Repairs

Should your repair not be covered by warranty the repair will be completed and payment will be required without notification or estimate of the expense unless the expense exceeds 50% of the retail purchase cost. By submitting the item for repair you are agreeing to payment of the repair without notification. Repair estimates are available upon request. You must include this request with your repair. Non-warranty repair estimates will be billed a minimum of ½ hour of labor. In addition you will be billed for return freight. Please advise us of your preferred method of payment. Horizon accepts money orders and cashiers checks, as well as Visa, MasterCard, American Express, and Discover cards. If you choose to pay by credit card, please include your credit card number and expiration date. Any repair left unpaid or unclaimed after 90 days will be considered abandoned and will be disposed of accordingly. ***Please note: non-warranty repair is only available on electronics and model engines.***

Electronics and engines requiring inspection or repair should be shipped to the following address:

Horizon Service Center
4105 Fieldstone Road
Champaign, Illinois 61822

All other Products requiring warranty inspection or repair should be shipped to the following address:

Horizon Product Support
4105 Fieldstone Road
Champaign, Illinois 61822

Please call 877-504-0233 with any questions or concerns regarding this product or warranty.

Safety, Precautions, and Warnings

As the user of this product, you are solely responsible for operating it in a manner that does not endanger yourself and others or result in damage to the product or the property of others.

Carefully follow the directions and warnings for this and any optional support equipment (chargers, rechargeable battery packs, etc.) that you use.

This model is controlled by a radio signal that is subject to interference from many sources outside your control. This interference can cause momentary loss of control so it is necessary to always keep a safe distance in all directions around your model, as this margin will help to avoid collisions or injury.

- Always operate your model in an open area away from cars, traffic, or people.
- Avoid operating your model in the street where injury or damage can occur.
- Never operate the model out into the street or populated areas for any reason.
- Never operate your model with low transmitter batteries.
- Carefully follow the directions and warnings for this and any optional support equipment (chargers, rechargeable battery packs, etc.) that you use.
- Keep all chemicals, small parts and anything electrical out of the reach of children.
- Moisture causes damage to electronics. Avoid water exposure to all equipment not specifically designed and protected for this purpose.

Fixed Gear Installation

Required Parts

Fixed main gear wire (right and left)
Landing gear block (2) 2mm x 10mm shoulder screw (4)
3mm x 6mm countersunk sheet metal screw (8)

Required Tools and Adhesives

Phillips screwdriver: #0, #1

- ○ 1. Insert the landing gear into the landing gear block.

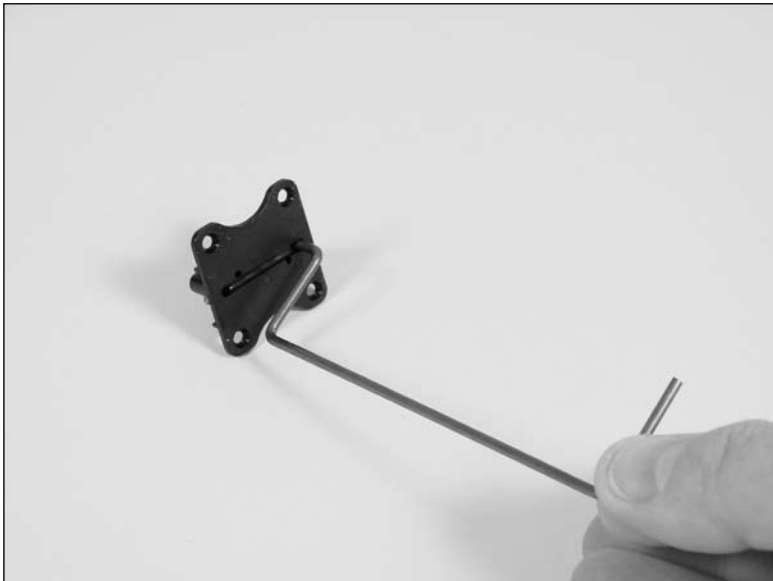

- ○ 2. Use two 2mm x 10mm shoulder screws and a #0 Phillips screwdriver to secure the landing gear to the landing gear block.

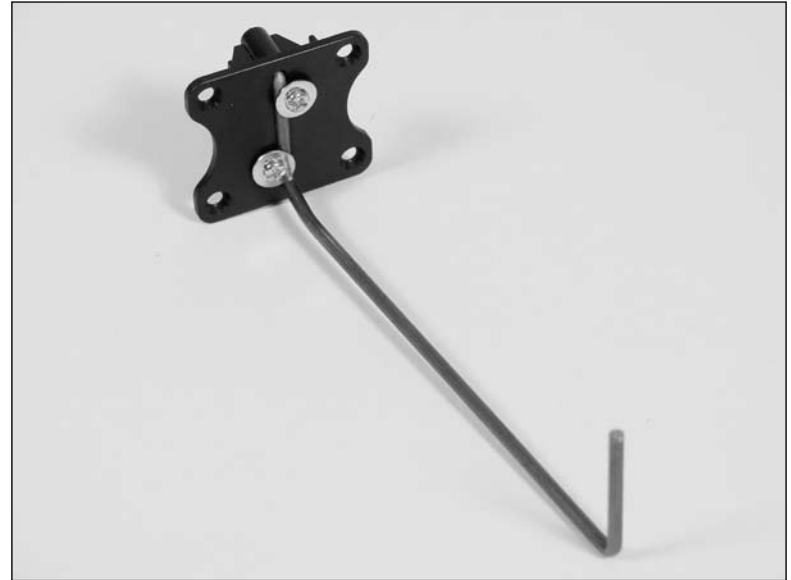

- 3. Repeat Steps 1 and 2 to assemble the second landing gear. (Make one left and one right)



- ○ 2. Apply a piece of double-sided tape onto each servo, on the side opposite the servo arm.

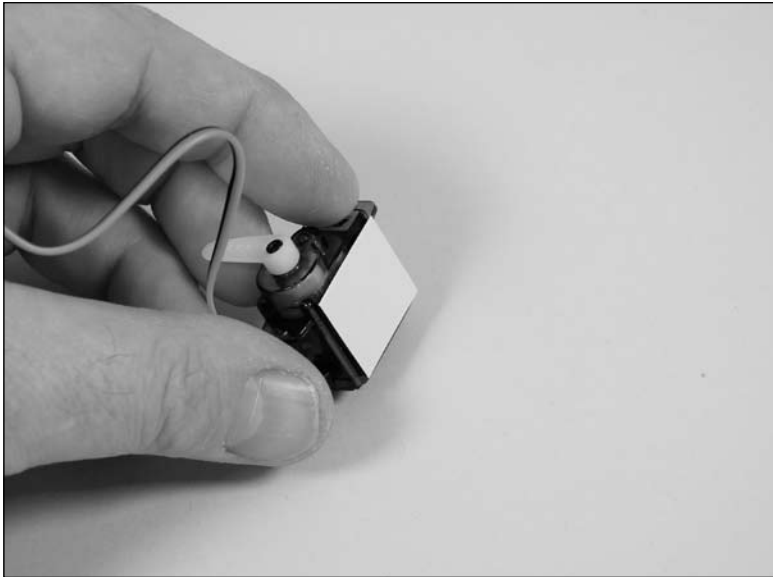

- ○ 3. Connect the retract linkage to the retract actuator arm.

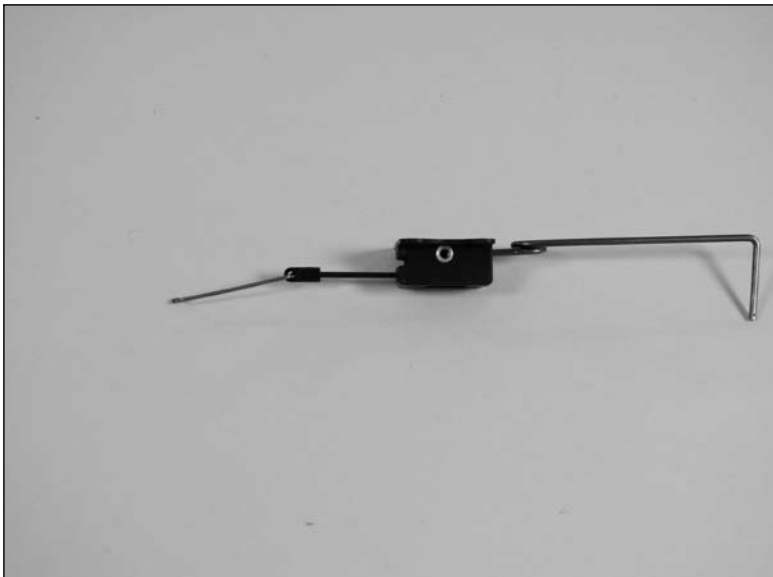

- ○ 4. Secure the retract assembly in the wing using a #1 Phillips screwdriver and four 3mm x 6mm countersunk sheet metal screws per assembly.

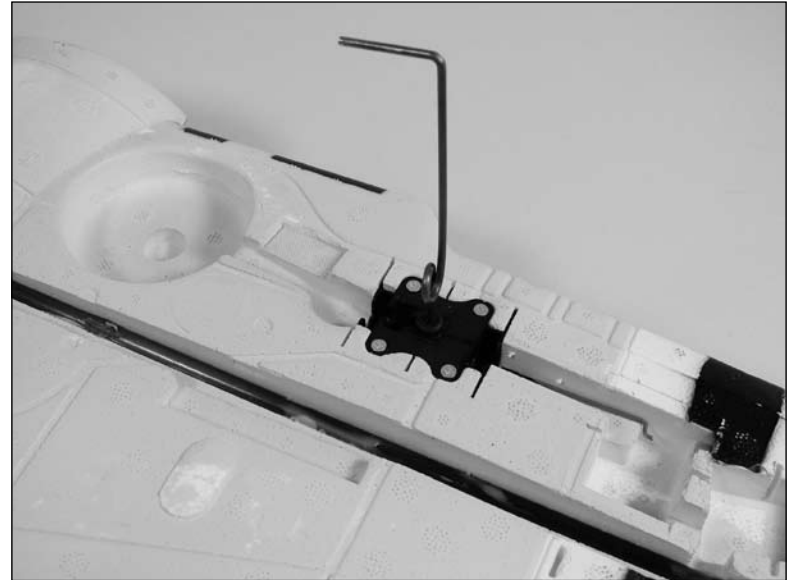

- 5. Place the retract in the Up position and insert the retract servo in the pocket. **Do not connect the linkage to the retract servo at this time.** Use the radio to move the servo arm to the Up position. Hold the linkage to the arm to make sure the linkage aligns with the servo arm. Adjust the end point at the radio to align the arm with the linkage.

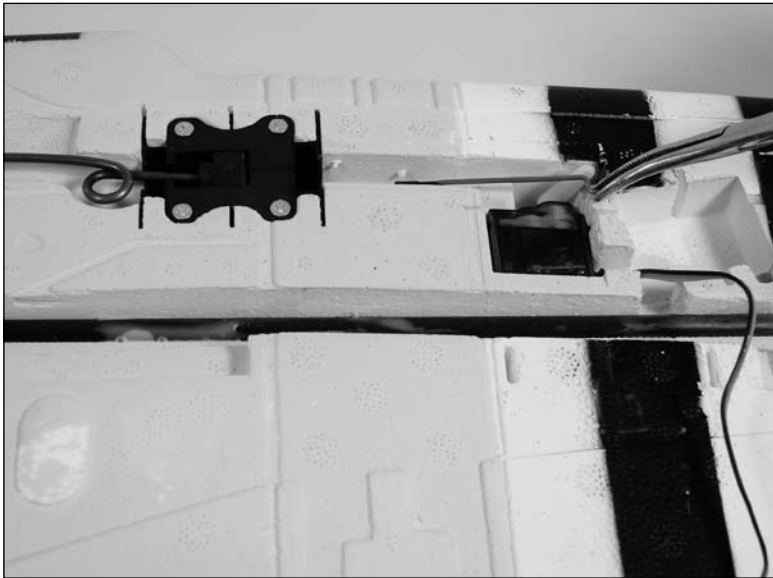

- 6. Place the retract in the down position and use the radio to move the servo to the down position. **Do not connect the linkage to the retract servo at this time.** Hold the linkage to the arm to make sure the linkage aligns with the servo arm. Adjust the end point at the radio to align the arm with the linkage.

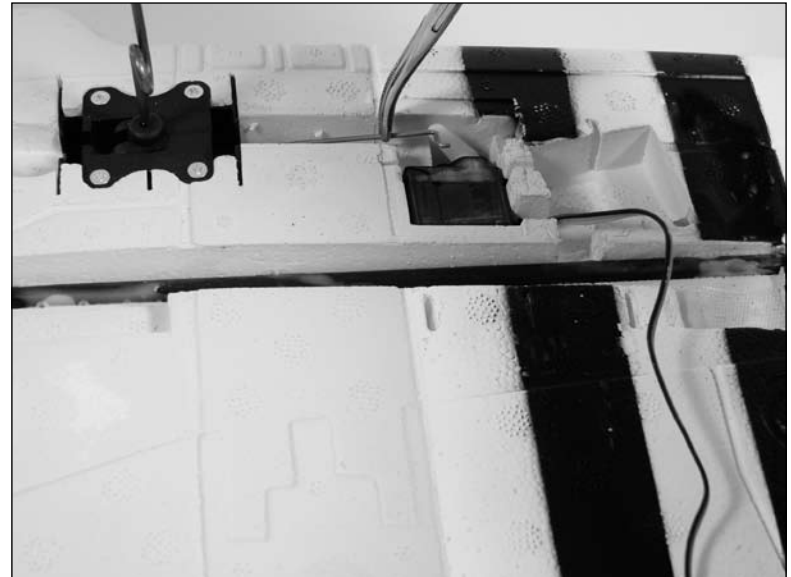

- ○ 7. Remove the servos once the end points have been adjusted and attach the linkage to the servo. Use a hobby knife to enlarge the hole in the servo arm if needed. Peel the backing tape off of the servo and mount it in position.

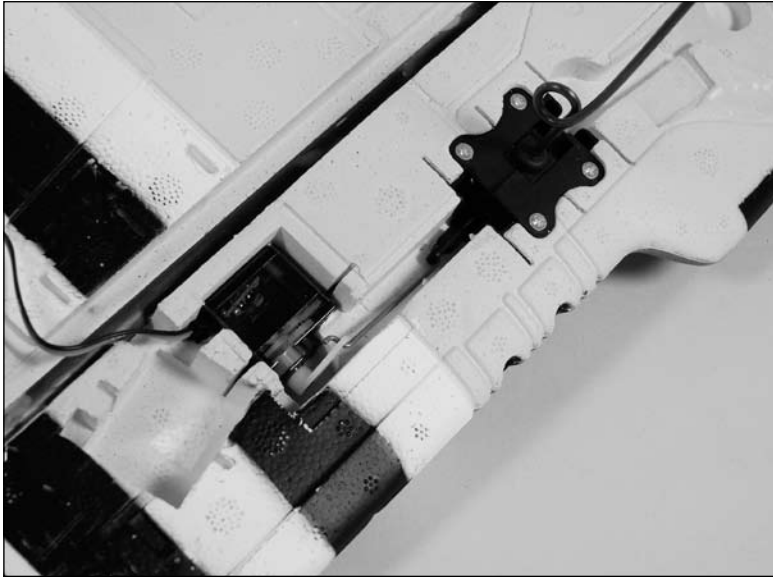

Note: If you are using a 6-channel or more computer radio you can use a separate channel for each of the retract servos. Using two channels and mixing them together will give you the option for independent adjustment of the travel adjustment of each servo. If you are not using a computer radio with mixing you will need to use a reversing Y-harness (EXRA320) instead.

- 8. Repeat Steps 2 through 7 to install the remaining retract and servo.

Aileron Servo Installation

Required Parts

- Aileron linkage w/clevis and keeper (2)
- Wing extension
- Wing Servo (2)
- Double-sided tape (2 pcs)
- 6-inch (152mm) extension
- 9-inch (228mm) extension (2) (for optional retracts)

Required Tools and Adhesives

- Hobby knife Foam-safe CA
- Phillips screwdriver: #0

- 1. Locate the wing extension and test fit it to the rear of the wing. Use foam-safe CA to glue the extension directly to the wing.





- 2. Prepare the aileron servos by installing the servo arms on the servos. Use your radio to center these servos at this time.

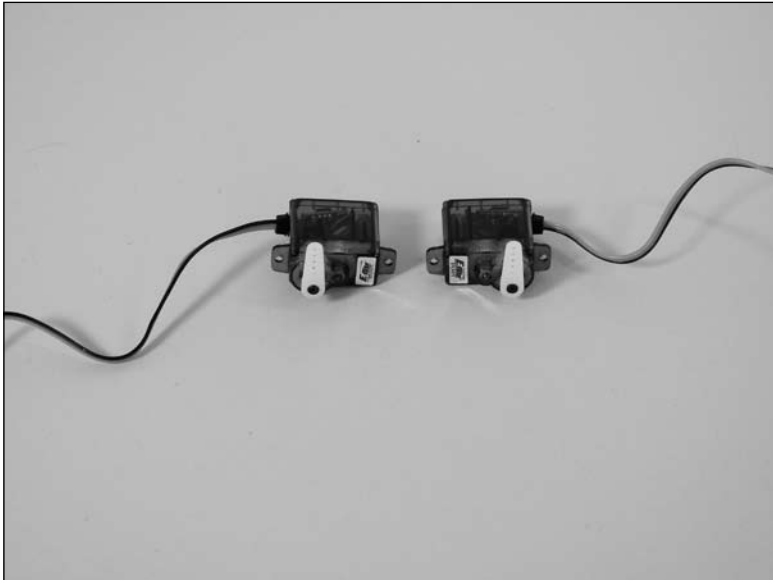

- 3. Apply a piece of double-sided tape onto each servo, on the side opposite the servo arm.

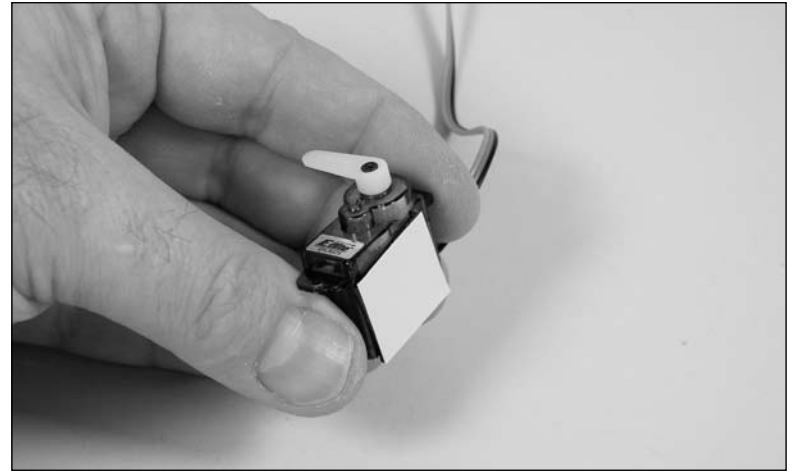

- 4. Remove the backing from the double-sided tape. Position the servo so the arm is facing toward the aileron and the outboard side off the wing. Press each aileron servo into the openings in the wing.



- 5. Connect a 6-inch (152mm) extension to each aileron servo lead. If you have opted to install retracts, attach a 9-inch (228mm) extension to each retract servo lead. Use string to secure the extension(s) so they do not unplug accidentally.

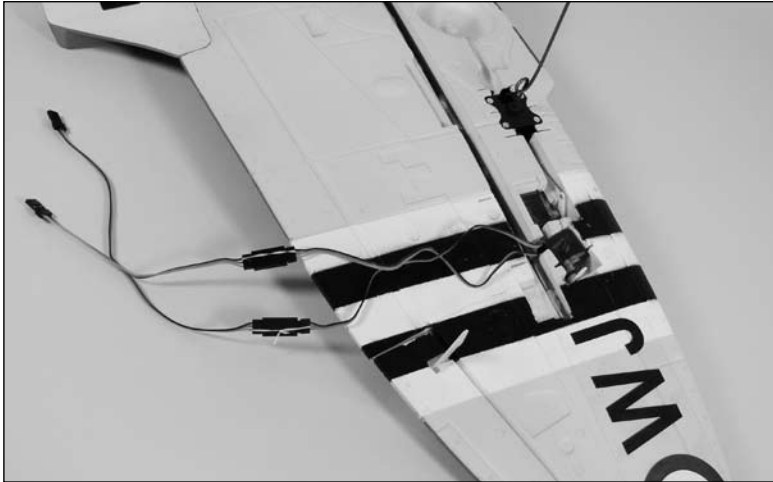

- 6. Route the leads for the aileron (and retract) servo(s) along the channel in the wing. The extension(s) then pass to the top of the wing through the hole in the center of the wing.

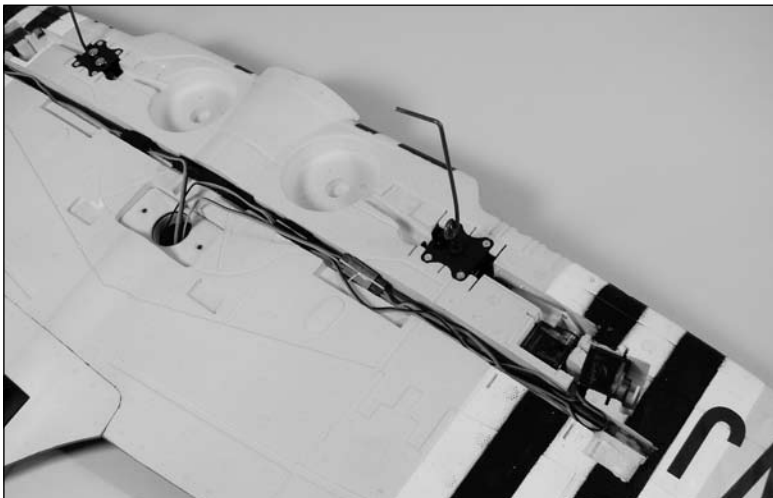

- 7. Remove the backing from the double-sided tape on the wing cover.

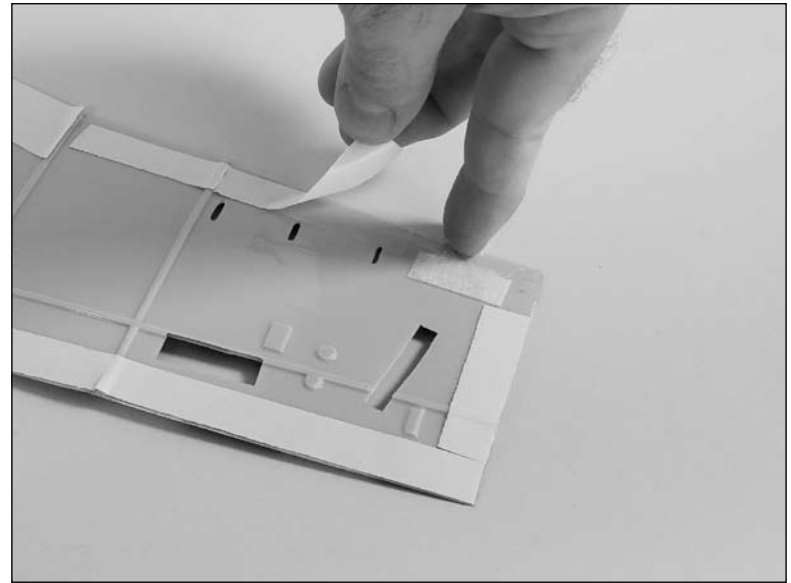

- 8. Carefully position the wing cover on the bottom of the wing. Make sure to align the cover when positioning it.

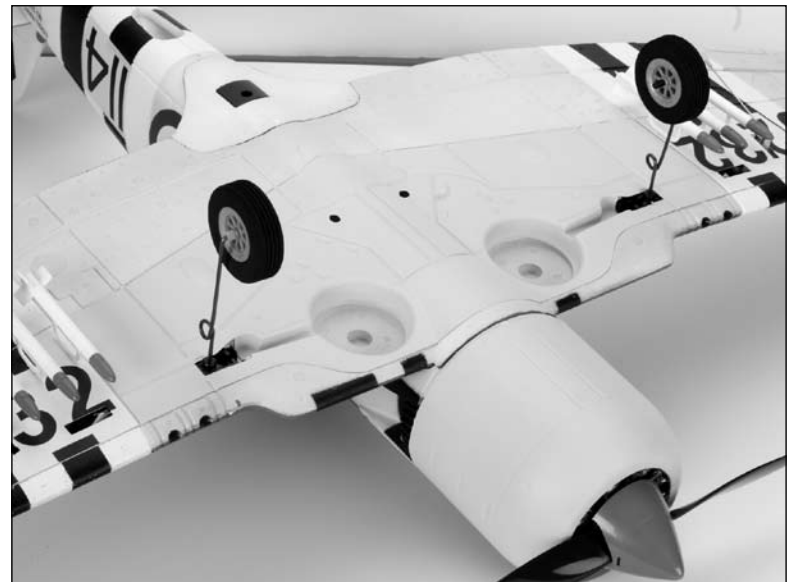

- ○ 9. Use a hobby knife to enlarge the outer hole on the aileron servo arm to accept the aileron linkage.



- ○ 10. Insert the Z-bend on the aileron linkage into the outer hole of the aileron servo horn.



- ○ 11. Connect the clevis of the aileron linkage to the aileron control horn. With the radio on, it may be necessary to adjust the length of the linkage so the aileron is centered.

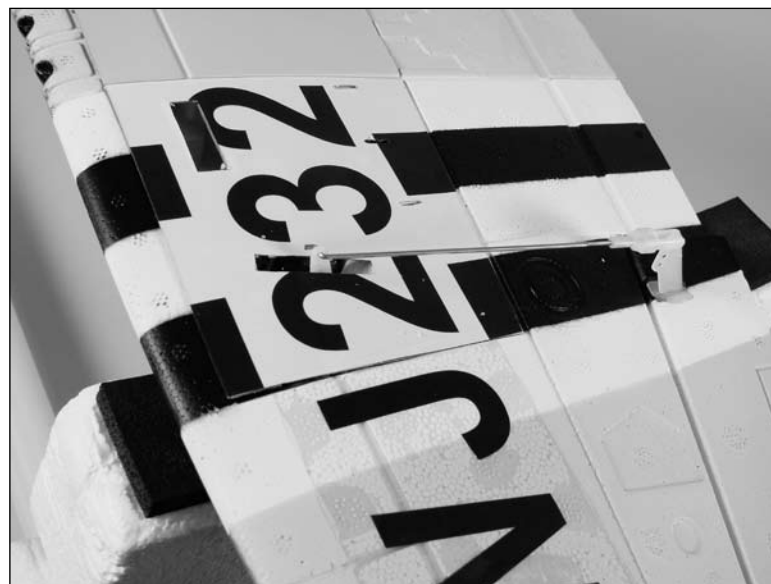

- 12. Repeat Steps 9 through 11 to connect the remaining aileron linkage.

Main Wheel Installation

Required Parts

Wheel spacer (2) Main wheel (2)
Wheel axle cap (2)

Required Tools and Adhesives

Foam-safe CA

Note: The wheel installation is the same for both fixed gear and retracts.

- 1. Slide the wheel spacer onto the landing gear axle.



- 2. Slide the wheel onto the landing gear axle.



- 3. Secure the wheel using the wheel axle cap and foam-safe CA. Use care not to get CA between the landing gear and wheel, which will prevent the wheel from rolling.



- 4. Repeat Steps 1 through 3 to install the remaining wheel.

Motor and Cowling Installation

Required Parts

Motor mount	6-inch (152mm) servo extension
Electronic speed control	1.5mm x 10mm self-tapping screw
Propeller	6-inch (152mm) battery extension
Motor w/accessories	Spinner backplate
Spinner cone	Spinner washer
3mm x 10mm machine screw (4)	
1/8-inch (3mm) spacer (4)	

Required Tools and Adhesives

Razor saw Phillips screwdriver: #00, #1

- 1. Attach the Park 450 motor to the mount using a #1 Phillips screwdriver and four 3mm x 10mm machine screws and the four 1/8-inch (3mm) spacers as shown.. Use threadlock on the screws to prevent the vibrations of the motor from loosening the screws.

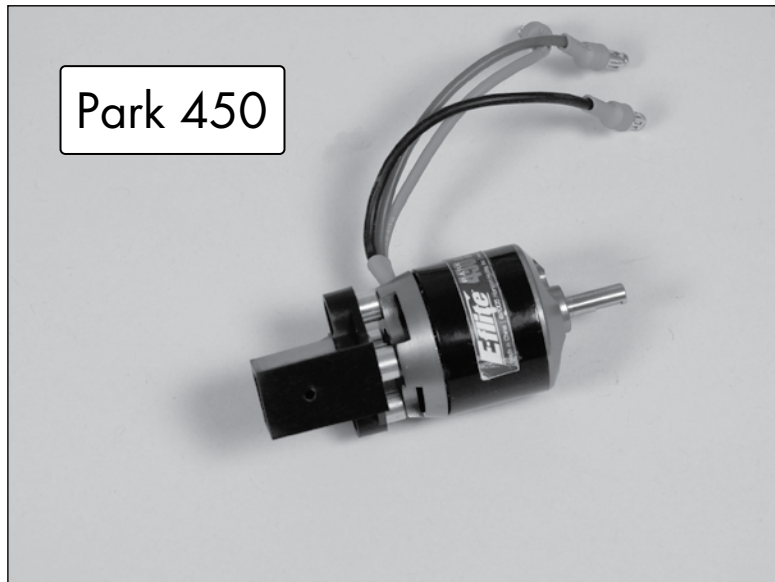

Note: When installing the Park 480 motor, use a #1 Phillips screwdriver, four 3mm x 10mm machine screws and the four 1/8-inch (3mm) spacers as shown. Use threadlock on the screws to prevent the vibrations of the motor from loosening the screws.

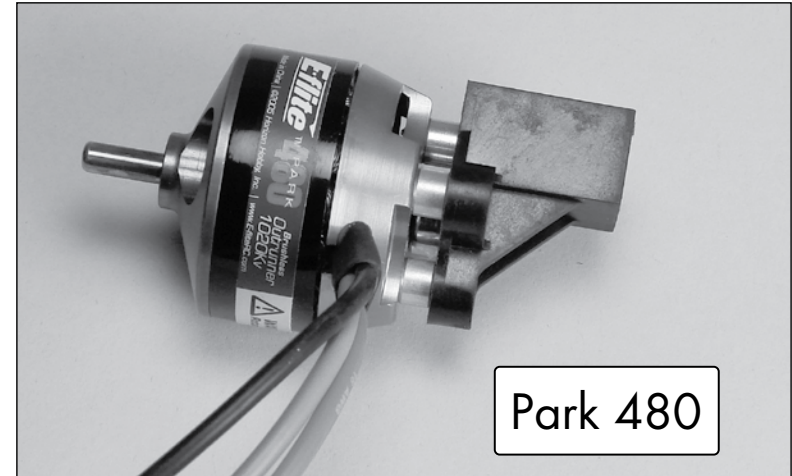

- 2. Use a razor saw to cut the length of the motor mounting stick to 15/16-inch (24mm) as shown below.

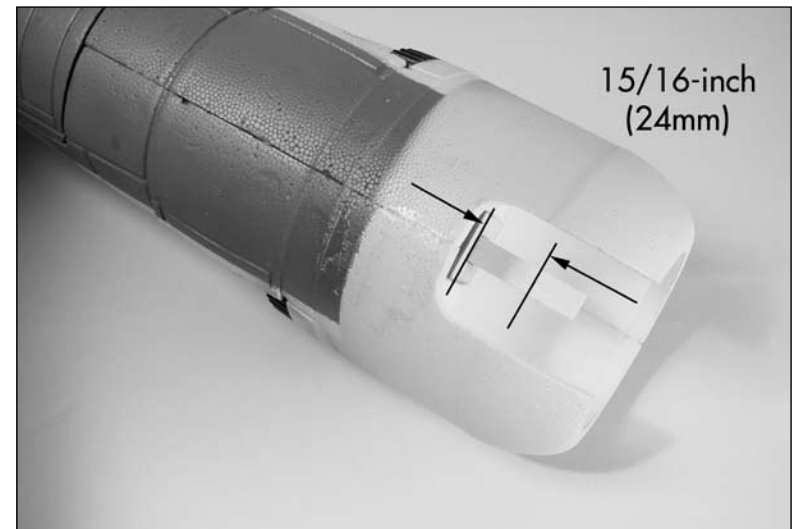

- 3. Lift the hatch from the fuselage as shown.

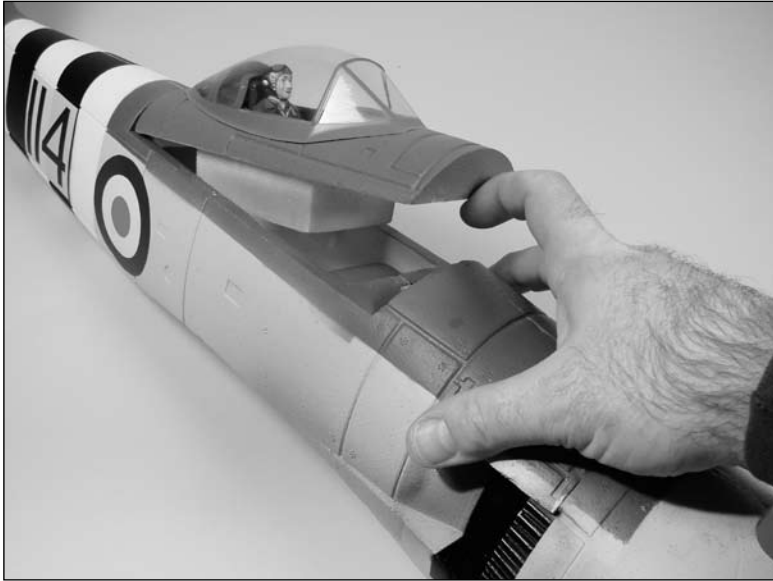

- 4. Remove the battery stop from the inside of the fuselage by sliding it rearward and out of the fuselage.



Important Information About Your Brushless ESC

Make sure your ESC brake is programmed to Off. Also, be sure to use an ESC with the proper low-voltage cutoff and have it set correctly for the batteries you are using.

Note: Never check the motor rotation on the bench with the propeller installed. The plane could move and cause serious injury. Always check the motor without the propeller to avoid injury.

- 5. Connect the battery and servo lead extensions to the speed control. Secure them using string to prevent them from being unplugged inside the fuselage.



- 6. Pass the battery and servo extensions into the lower hole in the fuselage and into the main radio compartment as shown below.



- 7. Secure the speed control inside the motor compartment using double-sided tape.

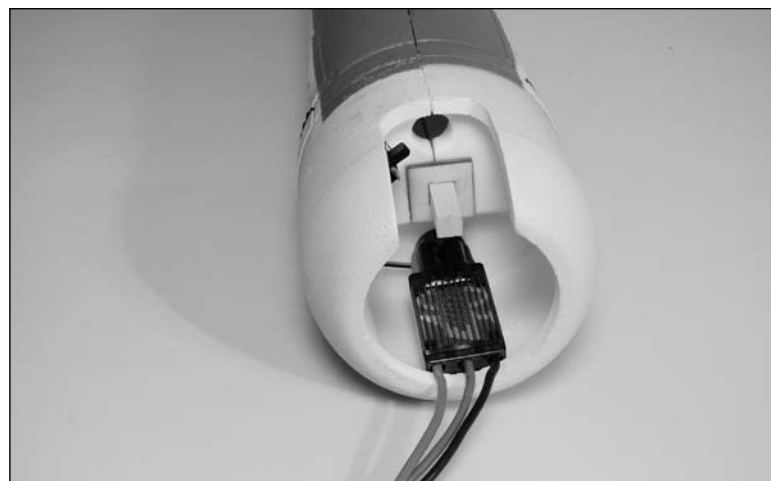

Note: If using the the Eflite 40-amp speed control, we recommend that you tape the switch in the On position and mount it inside the motor compartment or extend the leads so that it will reach the radio compartment.

- 8. Connect the leads from the motor to the speed control. Slide the motor mount onto the motor stick.



- 9. Secure the motor mount using the 1.5mm x 10mm self-tapping screw and a #00 Phillips screwdriver. Secure the wires inside the motor compartment so they will not interfere with the operation of the motor.



- 10. Check the operation of the motor at this time. It should rotate counterclockwise when viewed from the front of the aircraft. If not, follow the instructions provided with your speed control to correct the situation.
- 11. Remove the backing from the double-sided tape on both sides of the fuselage.

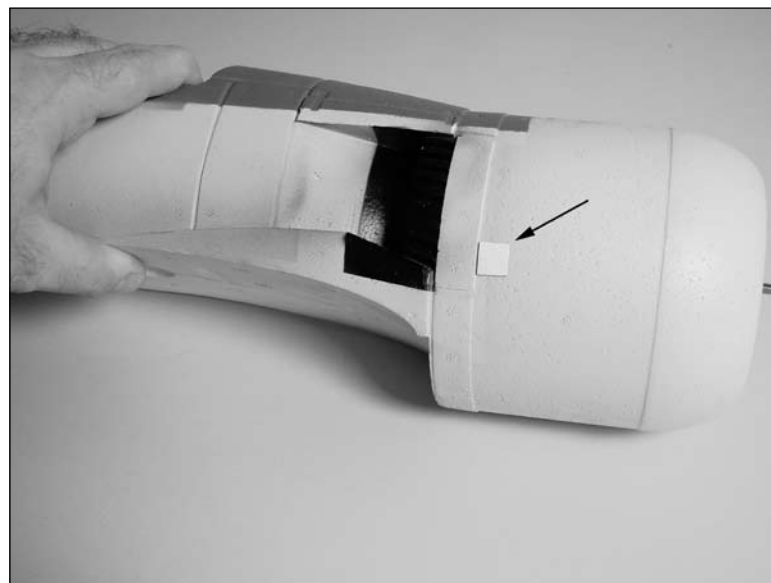

- 12. Slide the cowling onto the fuselage. Press the cowling against the tape to secure it in position.

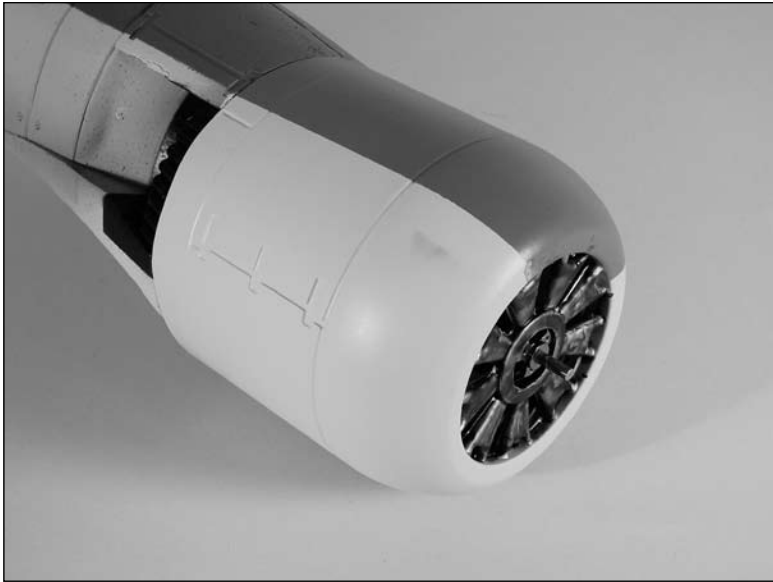

Important Information About Your Propeller

It is also very important to check to be sure the propeller is balanced before installing onto the shaft. An unbalanced propeller may strip the gears or cause poor flight characteristics.

Note: If it is necessary to enlarge the hole in the propeller or the spinner, make sure to check the balance of each afterwards.

- 13. Slide the propeller adapter into the propeller.



- 15. The spinner backplate is then placed on the adapter.



- 14. Next, slide the supplied washer onto the adapter.



- 16. Install the adapter nut, but do not tighten it at this time.



- 17. Place the spinner assembly on the motor shaft. Check that the positioning of the assembly will allow the backplate and propeller to spin without rubbing on the cowling. Tighten the adapter nut once all is well.

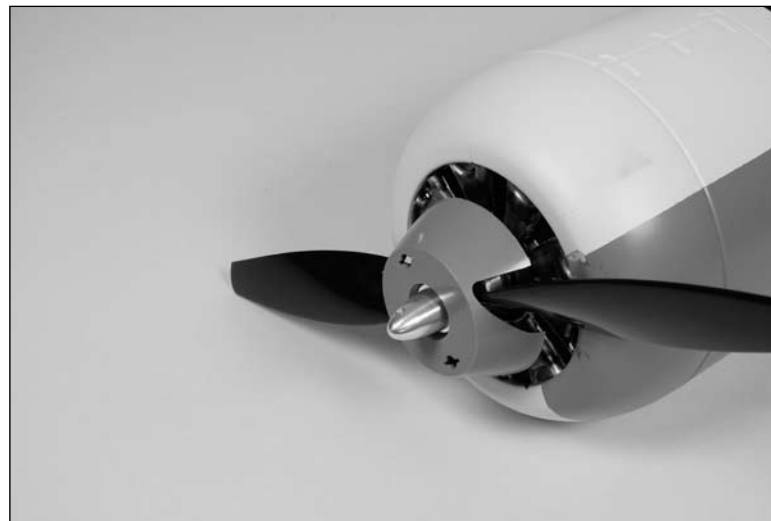

- 18. Snap the spinner cone onto the spinner backplate to complete the motor assembly.

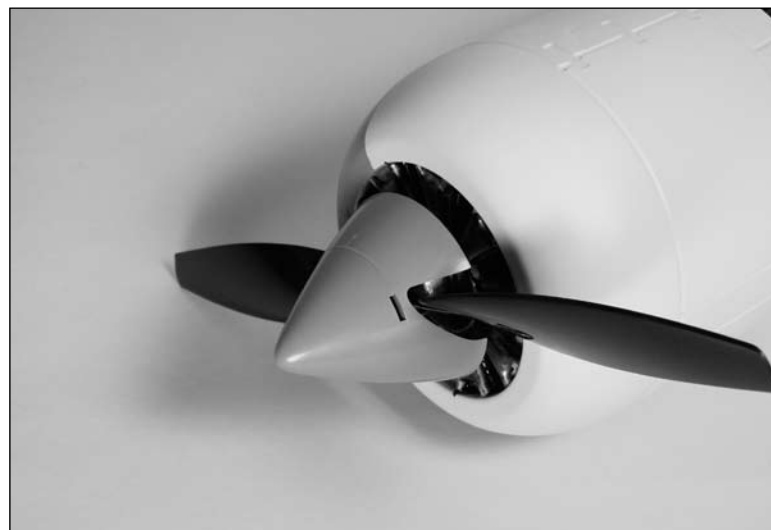

Radio Installation - Fuselage

Required Parts

Hook and loop tape Receiver
Y-harness (ailerons)
Servo (two required if using rudder control)

Required Tools and Adhesives

Phillips screwdriver: #0 Pin drill
Drill bit: 1/16-inch (1.5mm)

- 1. Mount the rudder and elevator servos in the fuselage using a pin drill and 1/16-inch (1.5mm) drill bit and the hardware provided with the servo.

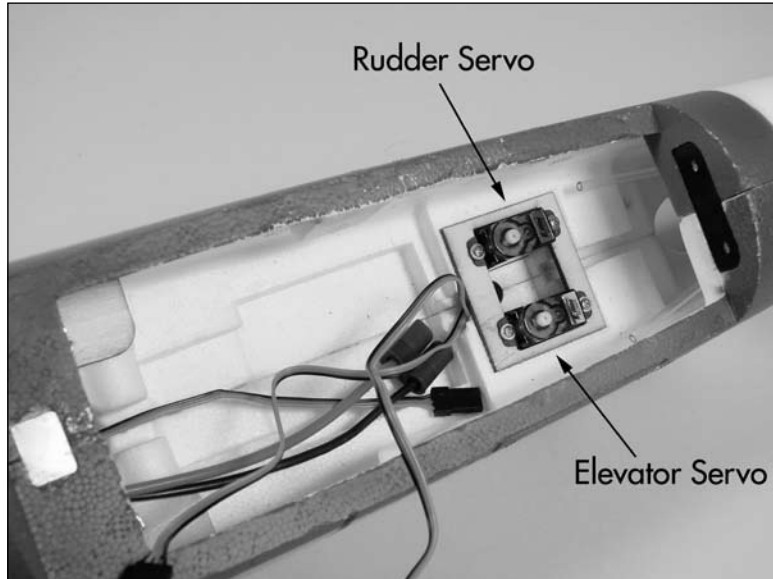

Note: If you have elected not to install the optional rudder, you will not need to install the rudder servo.

- 2. Plug the leads from the servos and speed control to the appropriate outputs on the receiver. Also connect the harness for the aileron servo to the receiver.

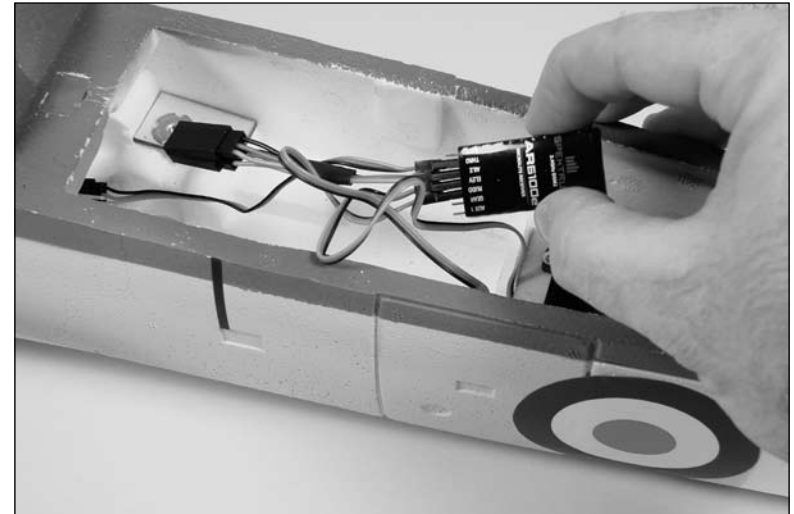

- 3. Use double-sided tape to secure the receiver in the fuselage as shown.



Tail Gear Installation - Fixed Rudder

Required Parts

Tail wheel collar w/setscrew Tail wheel
Wheel spacer Wheel axle cap
Fixed tail gear wire

Required Tools and Adhesives

Hex wrench: 1.5mm Foam-safe CA

Note: If you will be installing the operational rudder, skip to the next section of the manual.

- 1. Slide the tail wheel collar onto the tail wheel bearing. Align the setscrew with the notch in the bearing.

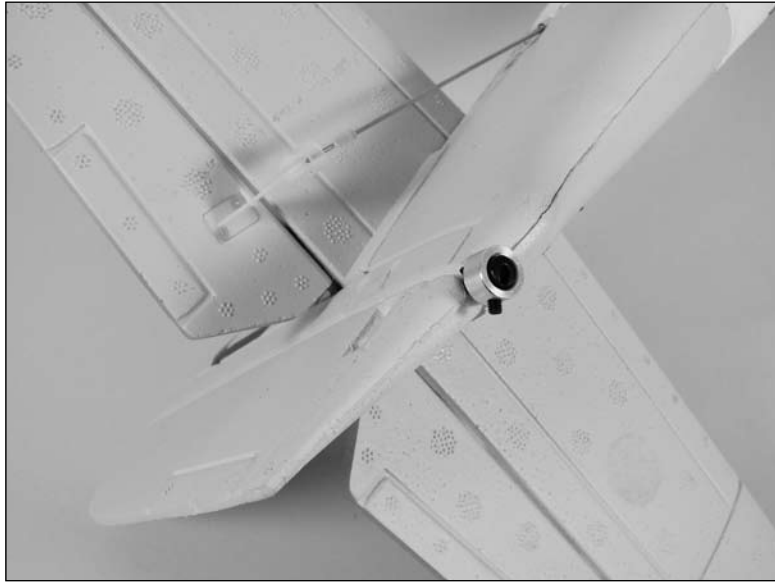

- 2. Slide the fixed gear tail wire into the bearing, then use a 1.5mm hex wrench to tighten the setscrew. The wire has a flat area for the setscrew to be tightened onto.



- 3. Slide the wheel spacer onto the tail gear wire.



- 4. Slide the tail wheel onto the tail gear wire.



- 5. Secure the wheel using the wheel axle cap and foam-safe CA. Use care not to get CA between the tail gear wire and wheel, which will prevent the wheel from rolling.



Optional Operable Rudder

Required Parts

Control horn	Control horn backplate
2mm x 10mm sheet metal screw (2)	
Operational tail gear wire	Tail wheel
Wheel spacer	Wheel axle cap

Required Tools and Adhesives

Hobby knife	Foam-safe CA
Drill bit: 1/8-inch (3mm)	Pin drill
Felt-tipped pen	Sandpaper

Note: Although the optional rudder can be installed after the stabilizer, it is much easier to do so before installing the stabilizer. The photos show the stabilizer installed for reference, even though the actual installation will be covered later in the manual.

- 1. Use a hobby knife to cut the rudder from the fin. Cut as close to the fin as possible for the best results.



- 2. Use sandpaper to remove any irregularities from the fin and rudder.

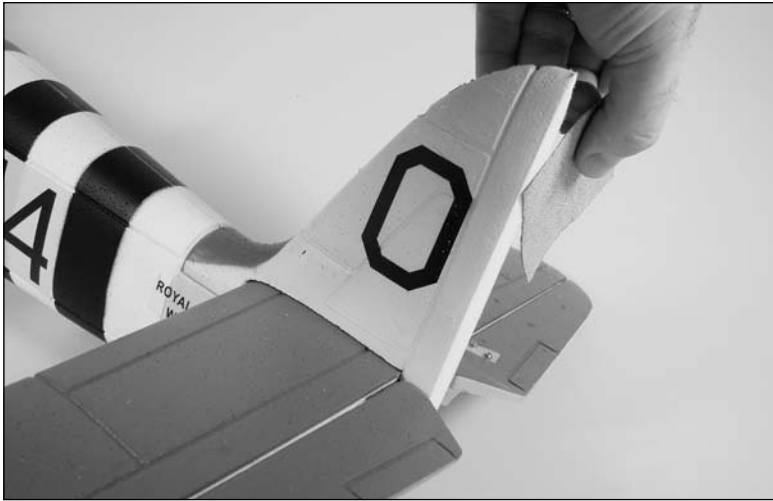

- 3. Mount the control horn to the rudder as shown using two 2mm x 10mm sheet metal screws, control horn backplate and a #1 Phillips screwdriver.



- 4. Cut slots in the rudder for the three rudder hinges. Use foam-safe CA to glue the hinges half-way into the rudder as shown.

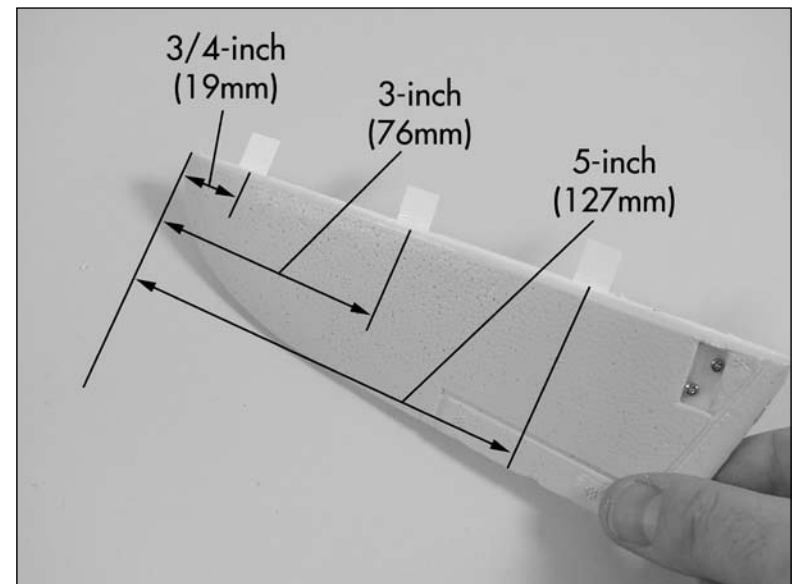

- 5. Use a pin drill and 1/8-inch (3mm) drill bit to drill a hole for the tail gear wire in the rudder.

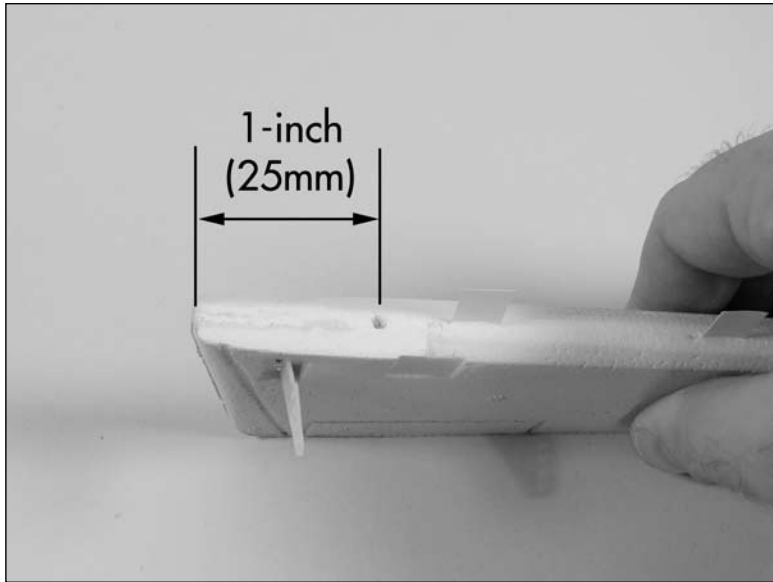

- 6. Hold the rudder against the fin and use a felt-tipped pen to transfer the location of the hinges to the fin.



- 7. Use a hobby knife to cut the slots for the rudder hinges in the fin.

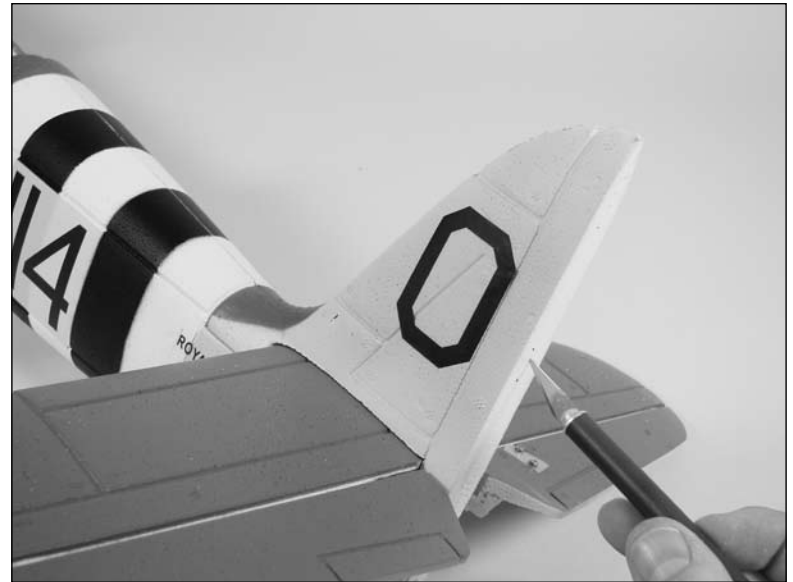

- 8. Slide the operational tail gear wire through the tail gear bushing as shown.

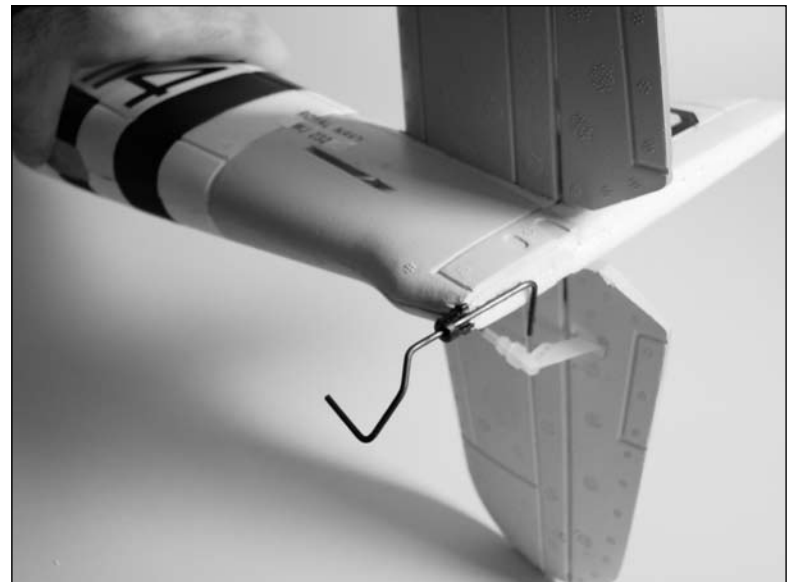

- 9. Test fit the rudder to the fin. Once satisfied with the fit, use foam-safe CA on the hinges and tail gear wire to secure the rudder to the fin. Make sure not to get CA in the tail gear assembly.



- 10. Slide the wheel spacer onto the tail gear wire.



- 11. Slide the tail wheel onto the tail gear wire.



- 12. Secure the wheel using the wheel axle cap and foam-safe CA. Use care not to get CA between the tail gear wire and wheel, which will prevent the wheel from rolling.



Stabilizer/Elevator Installation

Required Parts

Fuselage assembly Stabilizer assembly
13⁷/₃₂-inch (335mm) pushrod w/clevis
13⁹/₁₆-inch (345mm) pushrod w/clevis (for optional rudder)

Required Tools and Adhesives

Foam-safe CA

- 1. Remove the elevators and elevator joiner wire from the stabilizer.

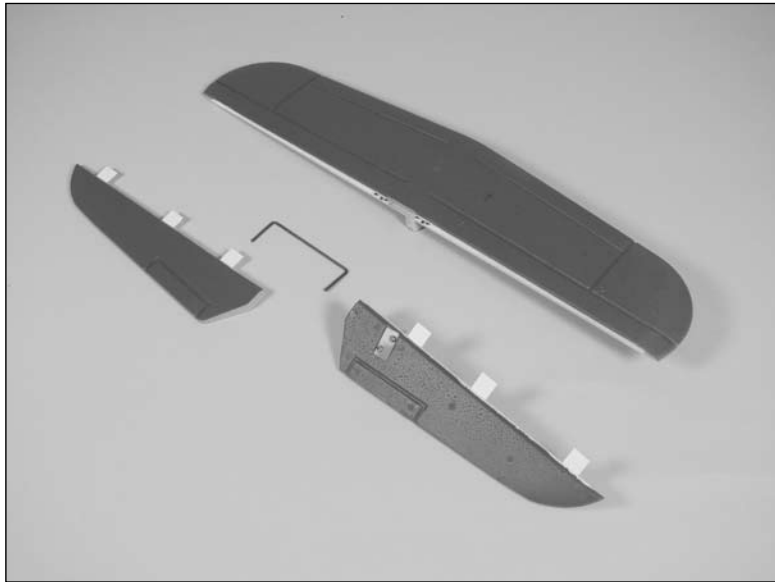

- 2. Place the elevator joiner wire in the slot in the fuselage for the stabilizer.



- 3. Slide the stabilizer into the slot in the fuselage. Measure the distance from each stabilizer tip to each wing tip. The measurements must be equal. Adjust the position of the stabilizer if necessary to correct for the alignment.

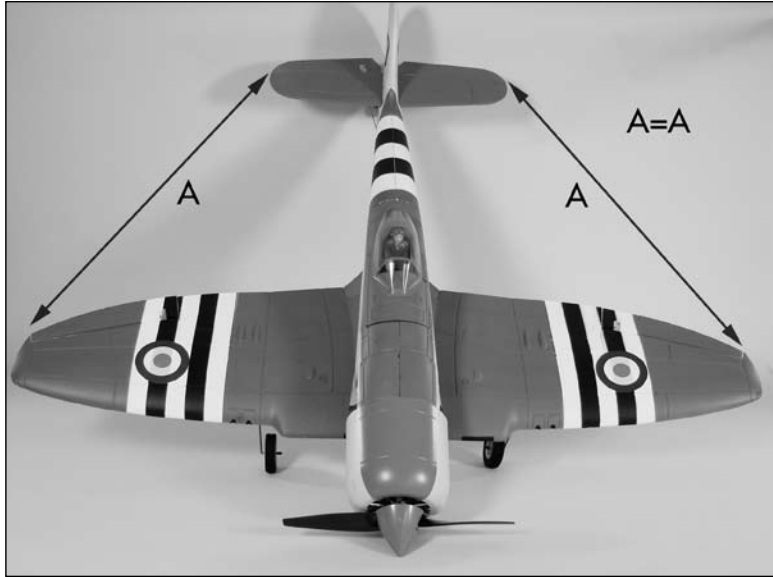

- 3. Stand back and view the model from the rear. The wing and stabilizer must be parallel to each other. Lightly sand the opening in the fuselage for the stabilizer to correct for any alignment issues.

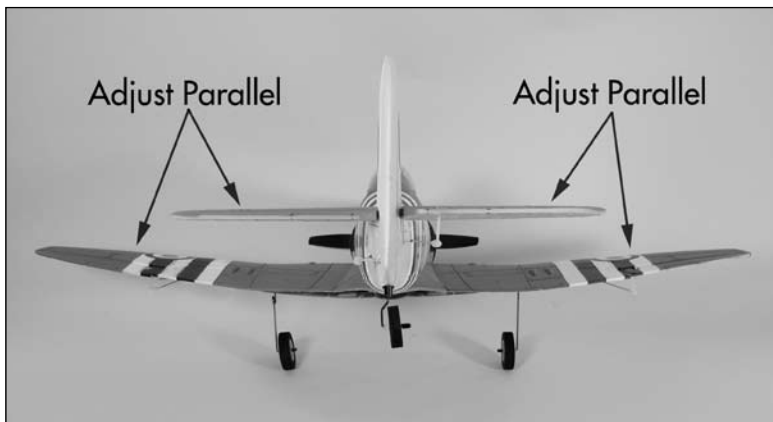

- 4. After aligning the stabilizer to the wing, use foam-safe CA. Double check the alignment one last time before the CA fully cures. Once the CA cures, snap the joiner wire back into the bracket at the trailing edge of the stabilizer.



- 5. Apply foam-safe CA to each side of the hinge, as well as to the elevator joiner wire.

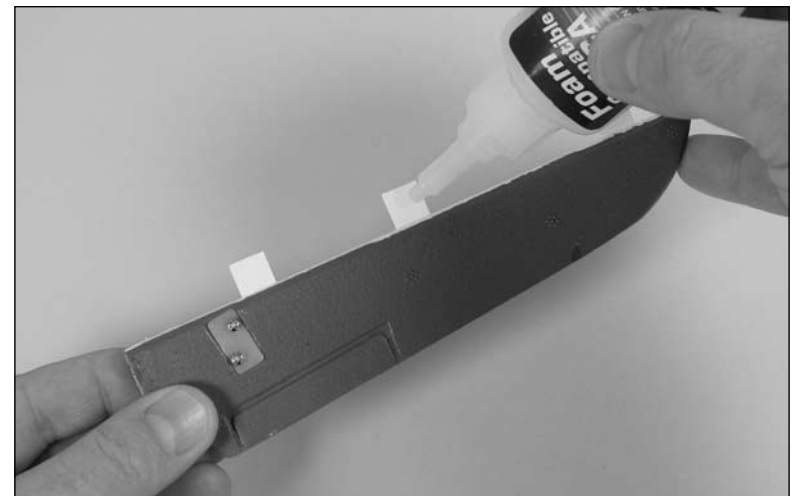

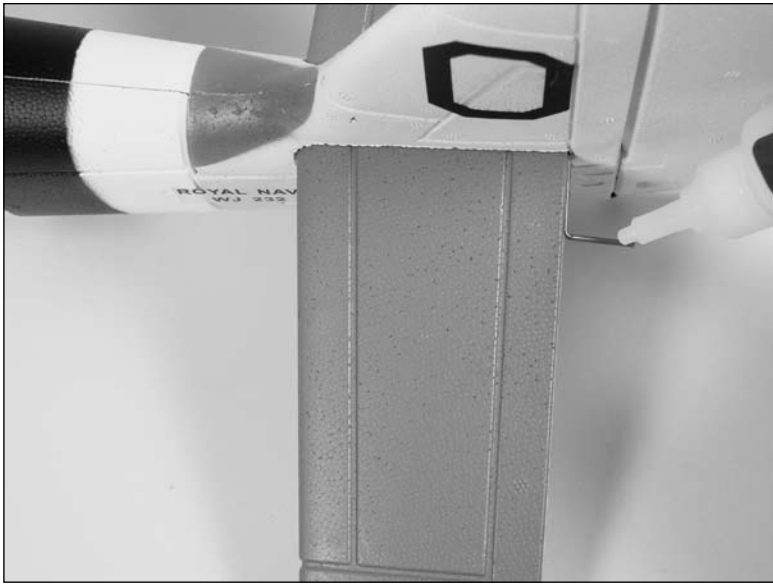

- 6. Attach both elevator halves to the stabilizer. Remember to work quickly to avoid having the CA cure before the elevator installation is complete.



- 7. Remove the clevis from the $1\frac{7}{32}$ -inch (335mm) pushrod. Slide the pushrod into the preinstalled tube in the fuselage.



- 8. Connect the bend in the pushrod to the elevator servo horn. Position the horn so the angle between it and the pushrod wire is 90 degrees. Secure the horn to the servo.

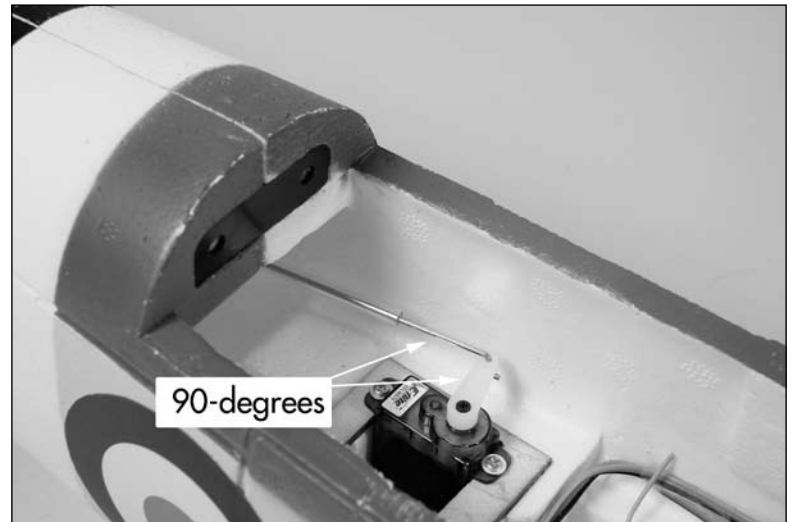

- 9. Thread the clevis back on the pushrod wire. Connect the clevis to the elevator control horn.

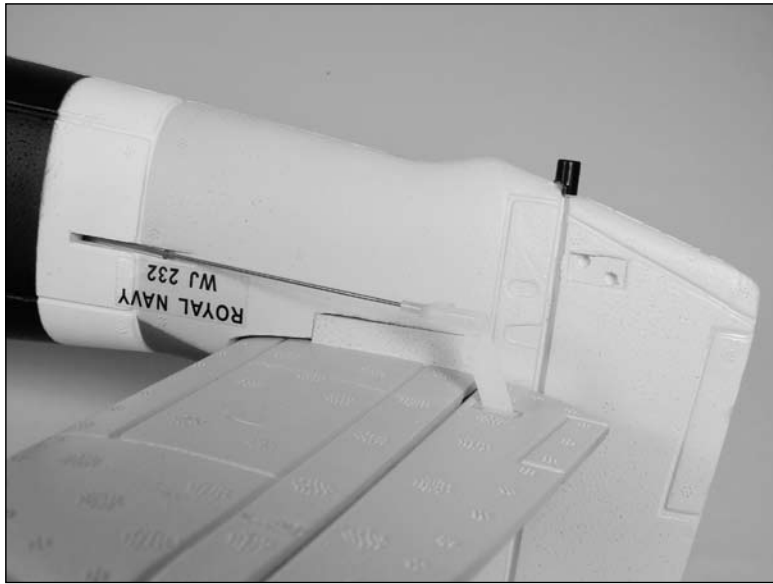

- 10. With the radio system on, adjust the position of the clevis so the elevator is parallel to the stabilizer.

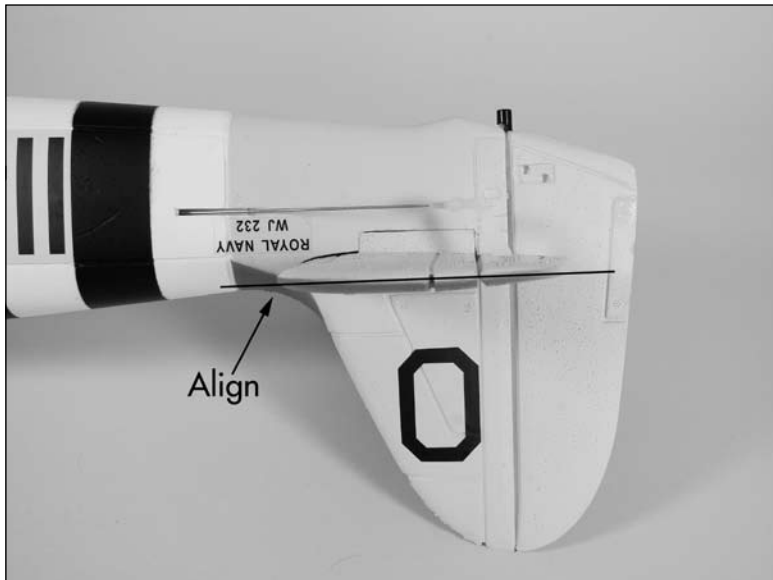

Linkage Installation for Optional Rudder

The next three steps cover the installation of the linkage for the optional rudder. Skip to the next section if you are not using the optional rudder.

- 11. Remove the clevis from the $13^{9}/16$ -inch (345mm) pushrod. Slide the pushrod into the preinstalled tube in the fuselage. Connect the bend in the pushrod to the rudder servo horn. Position the horn so the angle between it and the pushrod wire is 90 degrees. Secure the horn to the servo.

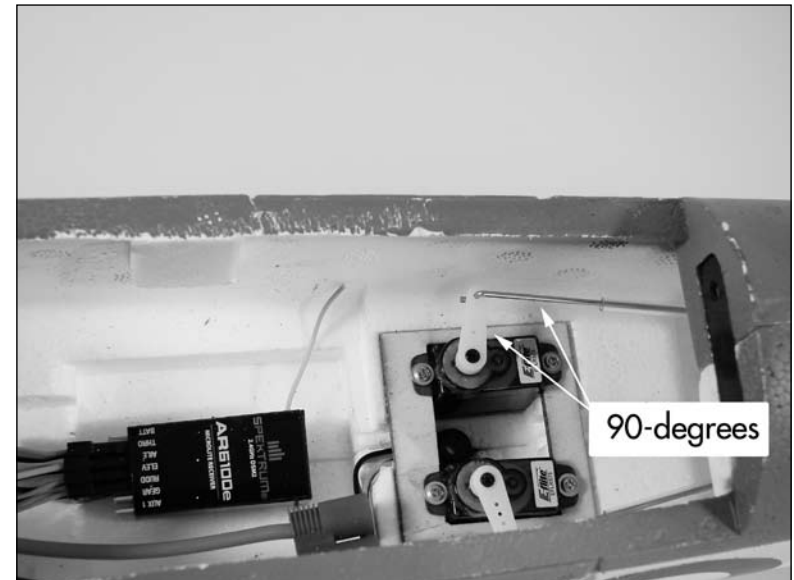

- 12. Thread the clevis back on the pushrod wire. Connect the clevis to the rudder control horn.

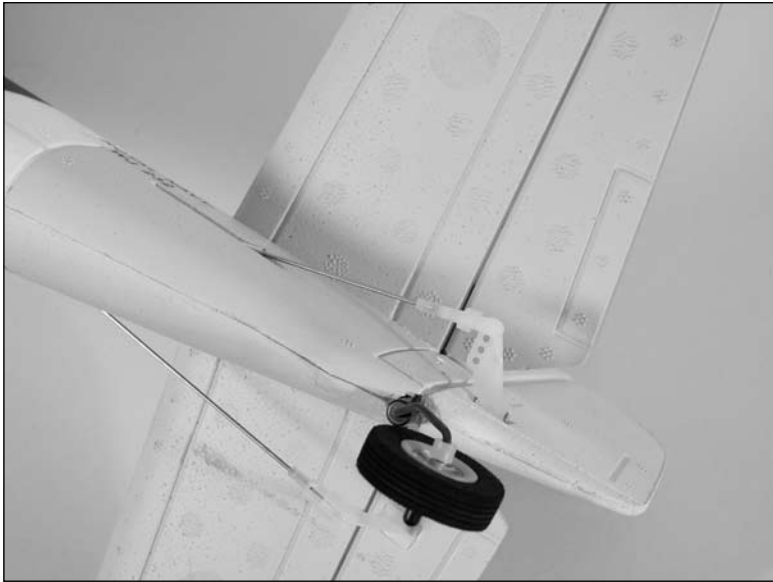

- 13. With the radio system on, adjust the position of the clevis so the rudder is parallel to the fin.

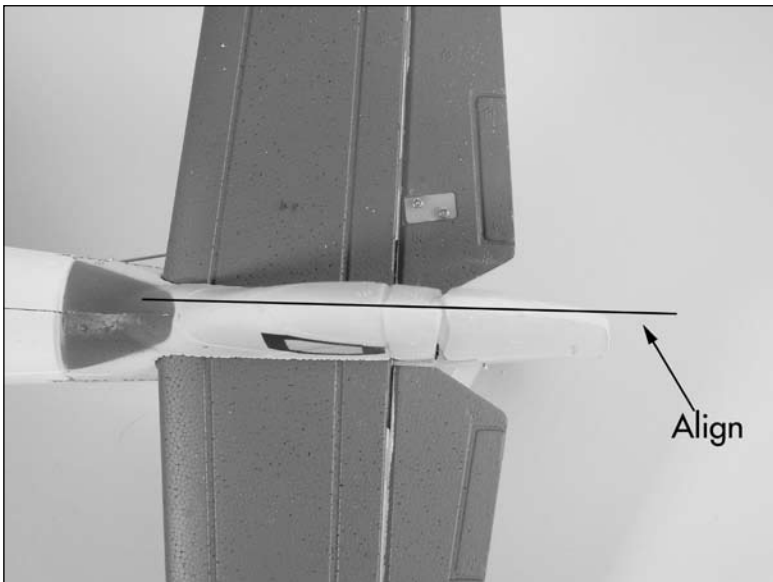

Final Assembly

Required Parts

- | | |
|--------------|------------------------------|
| Rocket (6) | 3mm x 45mm machine screw (2) |
| Battery stop | Canopy |

Required Tools and Adhesives

Phillips screwdriver: #1

- 1. Connect the aileron servo extensions to the aileron harness. The retract leads will pass into the fuselage and connect to the receiver with a Y-harness or plug directly into the receiver if using separate channels.



- 2. Secure the wing using two 3mm x 45mm machine screws in the center of the wing, and the preinstalled screw at the trailing edge of the wing. Use a #1 Phillips screwdriver to tighten the screws.

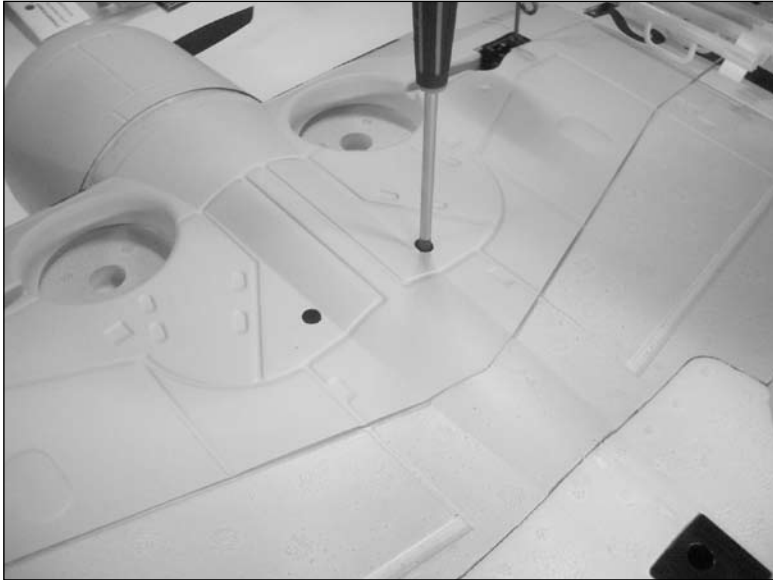

- 3. Slide the motor battery into the fuselage. Slide the battery as far forward as possible.



- 4. Connect the motor battery to the speed control.



Note: Make sure to be clear of the propeller when connecting the battery in case the motor starts unexpectedly.

- 5. Slide the battery stop back into the fuselage. If it is not fully in position, the canopy will not fit back onto the fuselage.

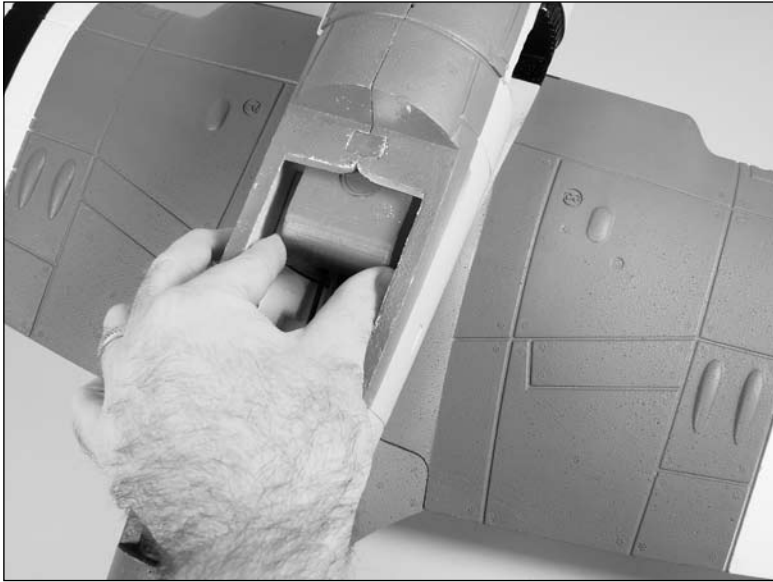

- 6. Place the canopy back onto the fuselage.



- 7. The rockets are installed by pressing them into the precut slots in the wing cover and into the slots in the wing.

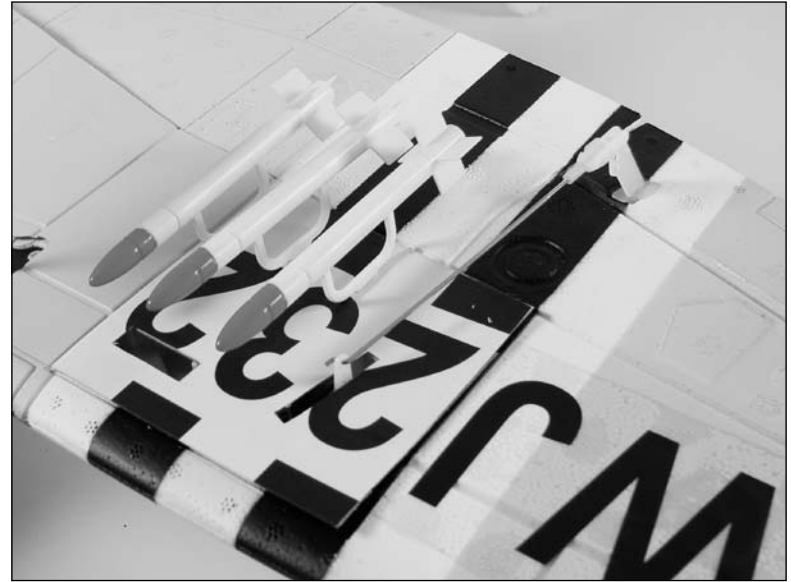

Control Throws

- 1. Turn on the transmitter and receiver of your Hawker Sea Fury. Check the movement of the rudder using the transmitter. When the stick is moved right, the rudder should also move right. Reverse the direction of the servo at the transmitter if necessary.
- 2. Check the movement of the elevator with the radio system. Moving the elevator stick down will make the airplane elevator move up.
- 3. Check the movement of the ailerons with the radio system. Moving the aileron stick right will make the right aileron move up and the left aileron move down.
- 4. Use a ruler to adjust the throw of the elevator, ailerons and rudder. Adjust the position of the pushrod at the control horn to achieve the following measurements when moving the sticks to their endpoints.

Note: Measurements are taken at the widest point on the surface.

Ailerons	D/R	Expo
Low Rate: 5/16-inch (8mm) (Up/Down)	60	10%
High Rate: 1/2-inch (13mm) (Up/Down)	100	15%

Elevator	D/R	Expo
Low Rate: 5/16-inch (8mm) (Up/Down)	60	15%
High Rate: 7/16-inch (11mm) (Up/Down)	100	20%

Rudder (optional)	D/R	Expo
Low Rate: 1/2-inch (13mm) (Right/Left)	60	10%
High Rate: 13/16-inch (20mm) (Right/Left)	100	20%

These are general guidelines measured from our own flight tests. You can experiment with higher rates to match your preferred style of flying.

Once all the control throws have been set, make sure to slide the clevis retainers over the clevises to prevent them from opening accidentally.



Center of Gravity

An important part of preparing the aircraft for flight is properly balancing the model.

Caution: Do not inadvertently skip this step!

Please balance your model inverted with the battery installed. With the model inverted, lift the model at the Center of Gravity (CG) marks molded into the wing using your fingertips, or use a commercially available balancing stand. The model will rest level or slightly nose down when balanced correctly. Add the clay weight supplied to the nose or tail if necessary to achieve the correct CG.



After the first flights, the CG position can be adjusted for your personal preference.

Range Test Your Radio

- 1. Please consult your radio instructions for complete range testing instructions.
- 2. Double-check that all controls (aileron, elevator, rudder and throttle) move in the correct direction.
- 3. Be sure that your transmitter batteries are fully charged, per the instructions included with your radio.

Instructions for Disposal of WEEE by Users in the European Union

This product must not be disposed of with other waste. Instead, it is the user's responsibility to dispose of their waste equipment by handing it over to a designated collection point for the recycling of waste electrical and electronic equipment. The separate collection and recycling of your waste equipment at the time of disposal will help to conserve natural resources and ensure that it is recycled in a manner that protects human health and the environment. For more information about where you can drop off your waste equipment for recycling, please contact your local city office, your household waste disposal service or where you purchased the product.



Preflight

Check Your Radio

Before going to the field, be sure that your batteries are fully charged per the instructions included with your radio. Charge both the transmitter and receiver pack for your airplane. Use the recommended charger supplied with your particular radio system, following the instructions provided with the radio. In most cases, the radio should be charged the night before going out flying.

Before each flying session, be sure to range check your radio. See your radio manual for the recommended range and instructions for your radio system. Each radio manufacturer specifies different procedures for their radio systems. Next, start the motor. With the model securely anchored, check the range again. The range test should not be significantly affected. If it is, don't attempt to fly! Have your radio equipment checked out by the manufacturer.

Note: Keep loose items that can get entangled in the propeller away from the prop. These include loose clothing, or other objects such as pencils and screwdrivers. Especially keep your hands away from the propeller.

Double-check that all controls (aileron, elevator, rudder and throttle) move in the correct direction.

Check the radio installation and make sure all the control surfaces are moving correctly (i.e. the correct direction and with the recommended throws). Test run the motor and make sure it transitions smoothly from off to full throttle and back. Also ensure the engine is installed according to the manufacturer's instructions, and it will operate consistently.

Check all the control horns, servo horns, and clevises to make sure they are secure and in good condition. Replace any items that would be considered questionable. Failure of any of these components in flight would mean the loss of your aircraft.

Flying Your Hawker Sea Fury ARF

Begin by placing the model on the ground. Check all control throws and ensure everything is traveling in the right direction. Move your idle trim up until the prop begins to spin; this will be your flight idle. Taxi into position on the runway, facing into the wind. Apply power slowly and steer with rudder. The tail will come up very quickly. As you apply full throttle and come to speed, apply a slight amount of up elevator and the Sea Fury should lift off gently and begin to climb upwards. As you climb, out release the elevator and maintain a gentle climb to about 100 feet of altitude.

Once at about 100 feet of altitude, trim the model for level flight at 5/8 throttle. You will find the Sea Fury to be very gentle on the control and feel quite light on the sticks. The model is capable of all the basic aerobatic maneuvers; loops, rolls, stall turns, inverted flight, etc.

If you have no roll issues with the model then you are ready to set up for landing. We normally do a pass over the runway on this pass. Turn into the downwind and manage the power at about 1/2 throttle. As you turn to base leg, you may reduce the throttle a bit and then when you turn final adjust the power to maintain a shallow descent with the model. As you come down to an altitude of about 8 feet over the runway, begin to level the model out and as you get within 3 feet, you will begin to flare for landing. The Sea Fury likes to be either landed on the mains or three pointed on the gear in a full stall. The choice is yours.

We at E-flite hope you enjoy your Sea Fury as much as we have. Happy landings!

2008 Official AMA National Model Aircraft Safety Code

GENERAL

- 1) I will not fly my model aircraft in sanctioned events, air shows or model flying demonstrations until it has been proven to be airworthy by having been previously, successfully flight tested.
- 2) I will not fly my model higher than approximately 400 feet within 3 miles of an airport without notifying the airport operator. I will give right-of-way and avoid flying in the proximity of full-scale aircraft. Where necessary, an observer shall be utilized to supervise flying to avoid having models fly in the proximity of full-scale aircraft.
- 3) Where established, I will abide by the safety rules for the flying site I use, and I will not willfully or deliberately fly my models in a careless, reckless and/or dangerous manner.
- 4) The maximum takeoff weight of a model is 55 pounds, except models flown under Experimental Aircraft rules.
- 5) I will not fly my model unless it is identified with my name and address or AMA number on or in the model. (This does not apply to models while being flown indoors.)
- 6) I will not operate models with metal-bladed propellers or with gaseous boosts, in which gases other than air enter their internal combustion engine(s); nor will I operate models with extremely hazardous fuels such as those containing tetranitromethane or hydrazine.

RADIO CONTROL

- 1) I will have completed a successful radio equipment ground range check before the first flight of a new or repaired model.
- 2) I will not fly my model aircraft in the presence of spectators until I become a qualified flier, unless assisted by an experienced helper.
- 3) At all flying sites a straight or curved line(s) must be established in front of which all flying takes place with the other side for spectators. Only personnel involved with flying the aircraft are allowed at or in front of the flight line. Intentional flying behind the flight line is prohibited.

- 4) I will operate my model using only radio control frequencies currently allowed by the Federal Communications Commission. (Only properly licensed Amateurs are authorized to operate equipment on Amateur Band frequencies.)
- 5) Flying sites separated by three miles or more are considered safe from site-to-site interference, even when both sites use the same frequencies. Any circumstances under three miles separation require a frequency management arrangement, which may be either an allocation of specific frequencies for each site or testing to determine that freedom from interference exists. Allocation plans or interference test reports shall be signed by the parties involved and provided to AMA Headquarters.

Documents of agreement and reports may exist between (1) two or more AMA Chartered Clubs, (2) AMA clubs and individual AMA members not associated with AMA Clubs, or (3) two or more individual AMA members.

- 6) For Combat, distance between combat engagement line and spectator line will be 500 feet per cubic inch of engine displacement. (Example: .40 engine = 200 feet.); electric motors will be based on equivalent combustion engine size. Additional safety requirements will be per the RC Combat section of the current Competition Regulations.
- 7) At air shows or model flying demonstrations, a single straight line must be established, one side of which is for flying, with the other side for spectators.
- 8) With the exception of events flown under AMA Competition rules, after launch, except for pilots or helpers being used, no powered model may be flown closer than 25 feet to any person.
- 9) Under no circumstances may a pilot or other person touch a powered model in flight.



© 2008 Horizon Hobby, Inc.
4105 Fieldstone Road
Champaign, Illinois 61822
(877) 504-0233
horizonhobby.com
E-fliteRC.com