

HORIZON
H O B B Y

Eflite
ADVANCING ELECTRIC FLIGHT

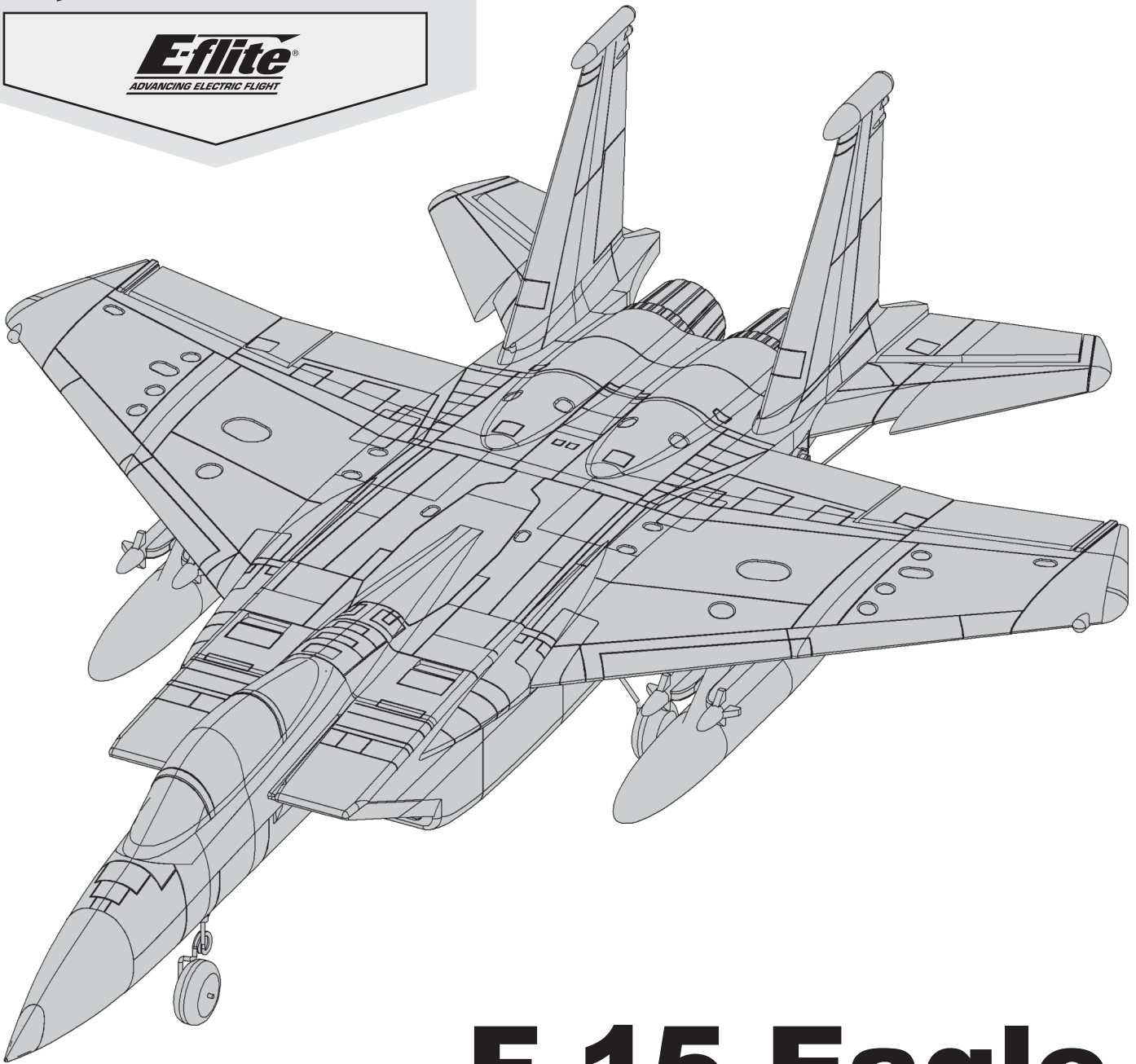

F-15 Eagle

64mm EDF

Instruction Manual
Bedienungsanleitung
Manuel d'utilisation
Manuale di Istruzioni

SAFE

SAFE® Select Technology, Optional Flight Envelope Protection

Bind-N-Fly® Plug-N-Play®
BASIC

NOTICE

All instructions, warranties and other collateral documents are subject to change at the sole discretion of Horizon Hobby, LLC. For up-to-date product literature, visit www.horizonhobby.com or www.towerhobbies.com and click on the support or resources tab for this product.

Meaning of Special Language

The following terms are used throughout the product literature to indicate various levels of potential harm when operating this product:

WARNING: Procedures, which if not properly followed, create the probability of property damage, collateral damage, and serious injury OR create a high probability of superficial injury.

CAUTION: Procedures, which if not properly followed, create the probability of physical property damage AND a possibility of serious injury.

NOTICE: Procedures, which if not properly followed, create a possibility of physical property damage AND little or no possibility of injury.



WARNING: Read the ENTIRE instruction manual to become familiar with the features of the product before operating. Failure to operate the product correctly can result in damage to the product, personal property and cause serious injury.

This is a sophisticated hobby product. It must be operated with caution and common sense and requires some basic mechanical ability. Failure to operate this Product in a safe and responsible manner could result in injury or damage to the product or other property. This product is not intended for use by children without direct adult supervision. Do not use with incompatible components or alter this product in any way outside of the instructions provided by Horizon Hobby, LLC. This manual contains instructions for safety, operation and maintenance. It is essential to read and follow all the instructions and warnings in the manual, prior to assembly, setup or use, in order to operate correctly and avoid damage or serious injury.

14+

AGE RECOMMENDATION:
Not for children under
14 years. This is not a toy.



WARNING AGAINST COUNTERFEIT PRODUCTS: If you ever need to replace your Spektrum receiver found in a Horizon Hobby product, always purchase from Horizon Hobby, LLC or a Horizon Hobby authorized dealer to ensure authentic high-quality Spektrum product. Horizon Hobby, LLC disclaims all support and warranty with regards, but not limited to, compatibility and performance of counterfeit products or products claiming compatibility with DSM or Spektrum technology.

Safety Precautions and Warnings

As the user of this product, you are solely responsible for operating in a manner that does not endanger yourself and others or result in damage to the product or the property of others.

- Always keep a safe distance in all directions around your model to avoid collisions or injury. This model is controlled by a radio signal subject to interference from many sources outside your control. Interference can cause momentary loss of control.
- Always operate your model in open spaces away from full-size vehicles, traffic and people.
- Always carefully follow the directions and warnings for this and any optional support equipment (chargers, rechargeable battery packs, etc.).
- Always keep all chemicals, small parts and anything electrical out of the reach of children.
- Always avoid water exposure to all equipment not specifically designed and protected for this purpose. Moisture causes damage to electronics.
- Never place any portion of the model in your mouth as it could cause serious injury or even death.
- Never operate your model with low transmitter batteries.
- Always keep aircraft in sight and under control.
- Always use fully charged batteries.
- Always keep transmitter powered on while aircraft is powered.
- Always remove batteries before disassembly.
- Always keep moving parts clean.
- Always keep parts dry.
- Always let parts cool after use before touching.
- Always remove batteries after use.
- Always ensure failsafe is properly set before flying.
- Never operate aircraft with damaged wiring.
- Never touch moving parts.

Box Contents

| Quick Start Information | | | |
|-------------------------------|---|----------------|-----------------|
| Transmitter Setup | Set up your transmitter using the transmitter setup chart | | |
| Travel and Dual Rates | | Hi Rate | Low Rate |
| | Aileron | 15mm | 12mm |
| | Elevator | 18mm | 14mm |
| Center of Gravity (CG) | 88mm +/-3mm back from leading edge of wing at the fuselage. | | |
| Flight Timer Setting | 3 minutes | | |

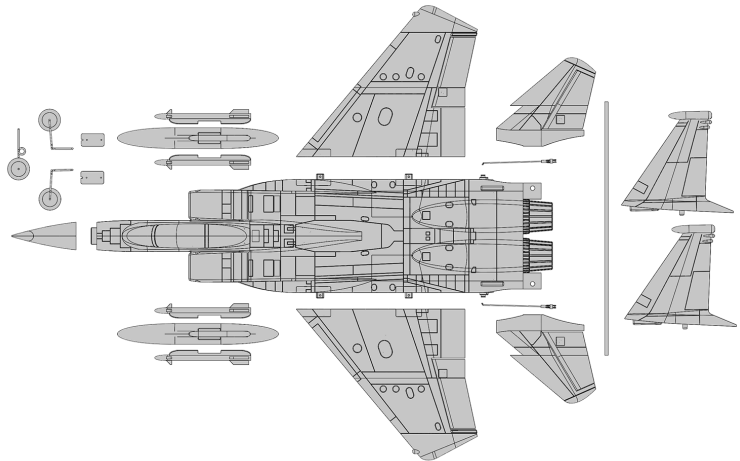

Components

| | | BNF BASIC | PNP PLUG-N-PLAY |
|--|---|-----------------------------|-----------------------------|
| | Motor: Brushless Outrunner 2840-3150 (EFL9787) | Installed | Installed |
| | ESC: 40A ESC (EFL9791) | Installed | Installed |
| | Servo: 9 gram servo | Installed | Installed |
| | Receiver: Spektrum™ AR630 SAFE and AS3X 6-Channel Receiver (SPMAR630) | Installed | Required to Complete |
| | Recommended Battery: 11.1-14.8V 3S or 4S 2200-2600mAh 30C Li-Po (SPMX22003S30, SPMX22004S30) | Required to Complete | Required to Complete |
| | Recommended Battery Charger: 3-4 cell Li-Po battery balancing charger | Required to Complete | Required to Complete |
| | Recommended Transmitter: Full-Range 6 channel (or more) 2.4GHz with Spektrum DSM2®/DSMX® technology with adjustable Dual Rates | Required to Complete | Required to Complete |

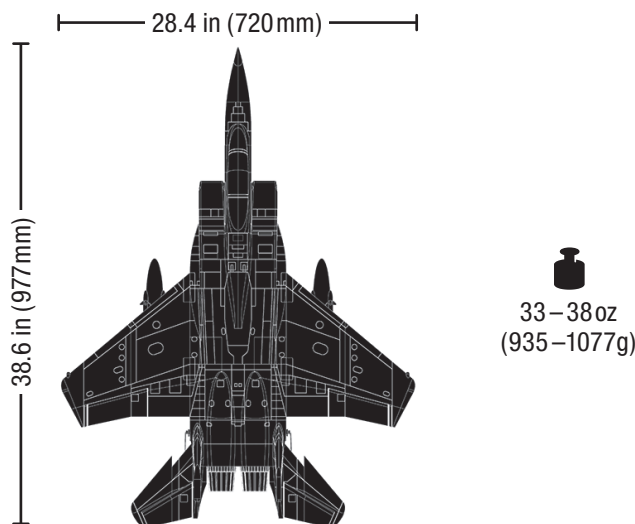

Table of Contents

| | |
|---|----|
| Safety Precautions and Warnings | 2 |
| Box Contents | 3 |
| Components | 3 |
| SAFE® Select Technology (BNF Basic) | 4 |
| Preflight | 4 |
| Transmitter Setup (BNF Basic) | 4 |
| Model Assembly | 5 |
| Transmitter and Receiver Binding / Enabling and Disabling SAFE Select (BNF Basic) | 8 |
| PNP Receiver Selection and Installation | 9 |
| Transmitter and Receiver Binding | 9 |
| Battery Installation and ESC Arming | 10 |
| SAFE® Select Switch Designation | 10 |
| Clevis Installation and Control Centering | 11 |
| Control Horn and Servo Arm Settings | 11 |
| Center of Gravity (CG) | 11 |
| Control Surface Direction | 12 |
| AS3X Control Direction Test (BNF Basic) | 12 |
| In Flight Trimming (BNF Basic) | 13 |
| Flying Tips and Repairs | 13 |
| Post Flight | 14 |
| Power Components Service | 14 |
| Troubleshooting Guide AS3X | 14 |
| Troubleshooting Guide | 15 |
| AMA National Model Aircraft Safety Code | 16 |
| Limited Warranty | 17 |
| Contact Information | 18 |
| FCC Information | 18 |
| IC Information | 18 |
| Compliance Information for the European Union | 18 |
| Replacement Parts | 67 |
| Optional parts | 67 |

| RECEIVER BIND INFORMATION | |
|---------------------------|-----------------|
| Channels | 6 |
| Frequency | 2405 – 2476 MHz |
| Compatibility | DSM2 and DSMX |

If you own this product, you may be required to register with the FAA.

For up-to-date information on how to register with the FAA, visit <https://registermyuas.faa.gov/>.

For additional assistance on regulations and guidance on UAS usage, visit knowbeforeyoufly.org/.

To receive product updates, special offers and more, visit www.horizonhobby.com/content/e-flite-rc

SAFE® Select Technology (BNF Basic)

The evolutionary SAFE® Select technology can offer an extra level of protection so you can perform the first flight with confidence. No complex transmitter programming is required. Just follow the simple bind process to make the SAFE Select system active. When activated, bank and pitch limitations keep you from over-controlling and automatic self-leveling makes recovery from risky or confusing attitudes as simple as releasing the sticks. In fact, with the aileron, elevator and rudder sticks in the neutral position, SAFE Select will automatically keep the airplane in a straight and level attitude.

Expand the advantage of what SAFE® Select technology offers by assigning it to a switch. No transmitter programming is required and you'll be able to turn the system ON and OFF with the flip of a switch. For example, turn SAFE select ON for takeoffs to counter cross winds. Turn it OFF in flight for unrestricted aerobatic performance, and turn it back ON when a buddy wants to try out your cool aircraft. Turn SAFE Select ON for landings. SAFE Select reduces your workload by compensating for pitch changes automatically, regardless of throttle position. It will help keep the correct pitch attitude and wings level during the final approach. Whether you're a beginner or an expert, SAFE Select can make your flights a great experience. When the normal bind process is followed, the SAFE Select system is disabled, leaving specially tuned AS3X® technology in place to deliver a pure, unrestricted flight experience.

Preflight

| | |
|---|--|
| 1. Remove and inspect contents. | 9. Make sure linkages move freely. |
| 2. Read this instruction manual thoroughly. | 10. Perform the Control Direction Test with the transmitter. |
| 3. Charge the flight battery. | 11. Perform the AS3X Control Direction Test with the aircraft. |
| 4. Setup Transmitter using transmitter setup chart. | 12. Adjust flight controls and transmitter. |
| 5. Fully assemble the airplane. | 13. Perform a radio system Range Test. |
| 6. Install the flight battery in the aircraft (once it has been fully charged). | 14. Find a safe open area to fly. |
| 7. Check the Center of Gravity (CG). | 15. Plan flight for flying field conditions. |
| 8. Bind the aircraft to your transmitter. | |

Transmitter Setup (BNF Basic)

Dual Rates

Take first flights in Low Rate. For landings, use high rate elevator.

NOTICE: To ensure AS3X® technology functions properly, do not lower rate values below 50%. If lower rates are desired, manually adjust the position of the pushrods on the servo arm.

NOTICE: If oscillation occurs at high speed, refer to the Troubleshooting Guide for more information.

Expo

After first flights, you may adjust expo in your transmitter for each channel to fit your flying style.

Computerized Transmitter Setup

Start all transmitter programming with a blank ACRO model (perform a model reset), then name the model.

| | |
|---------------------|-----------|
| Set Dual Rates to | HIGH 100% |
| | LOW 70% |
| Set Servo Travel to | 100% |
| Set Throttle Cut to | -130% |

Model Assembly

Landing Gear Installation

1. Install the nose gear with set screws. Use thread locking compound on the set screws. The flat spot will make the connection straight and secure.
2. Install the main gear with covers using the M2x8 flat head screws.

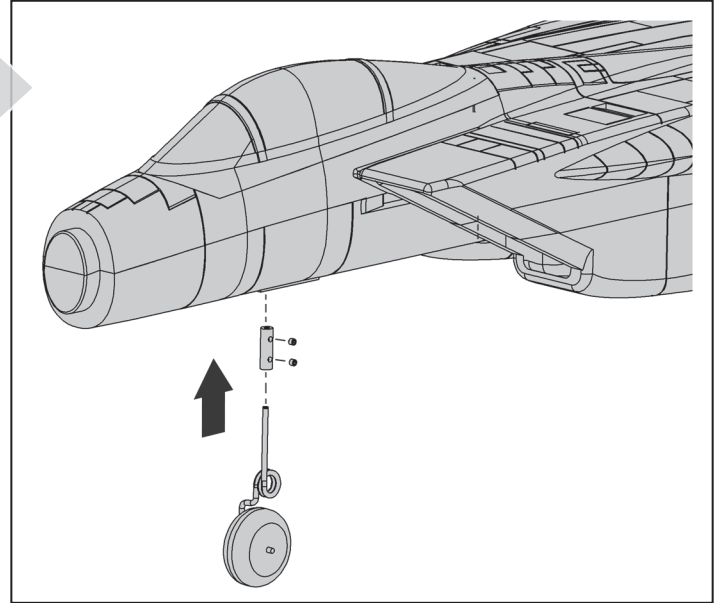
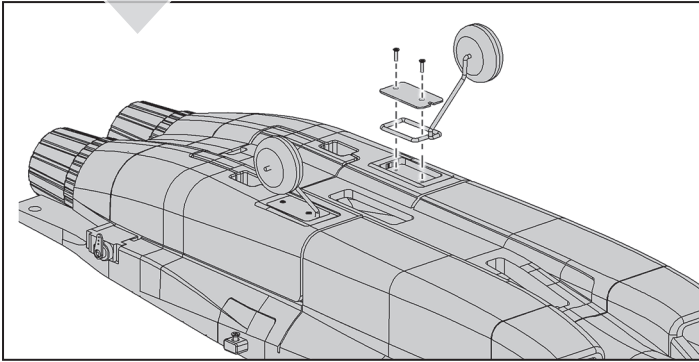

Wing Installation

1. Slide the wing tube into the fuselage.
2. Slide the wing panels on the wing tube. Ensure the wing panels are tight against the fuselage.

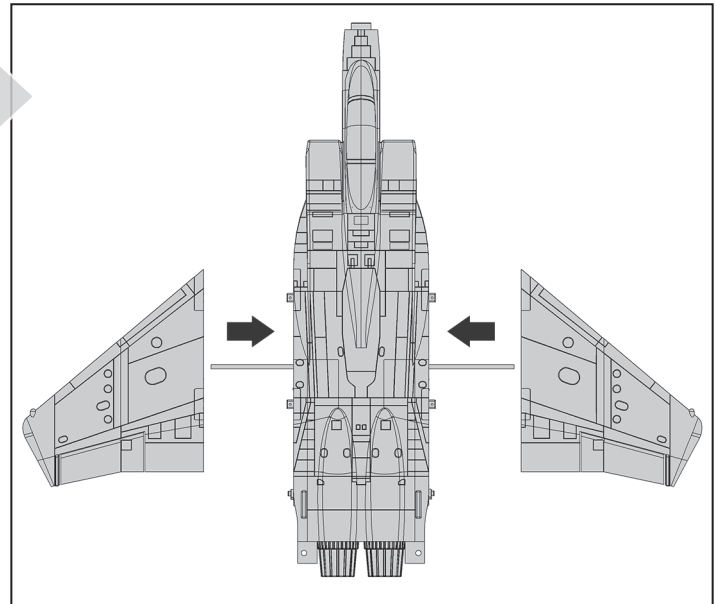

3. Using a 2mm hex wrench, install 4-M3x10 flat head screws to secure the main wing panels.
4. Connect the servo leads **firmly**. Make sure the wires are secure in the wing using the colored decals.

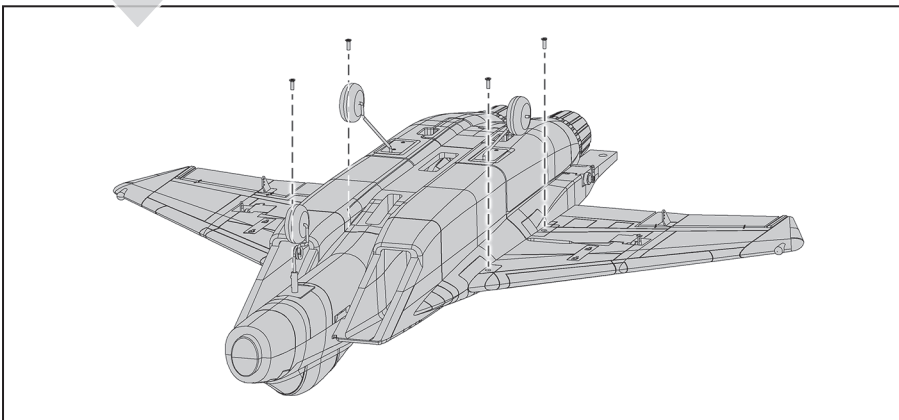

Model Assembly *Continued*

Horizontal Stabilizer Installation

1. Apply regular, (not Foam Safe) medium CA to the base of the horizontal stabilizer where it meets the fuselage.
2. Make sure the control horn faces down toward the bottom and fit each horizontal stabilizer to the fuselage.

IMPORTANT! Make sure the horizontal stabilizer is in alignment with the wing. Adjust as necessary before the CA fully cures.

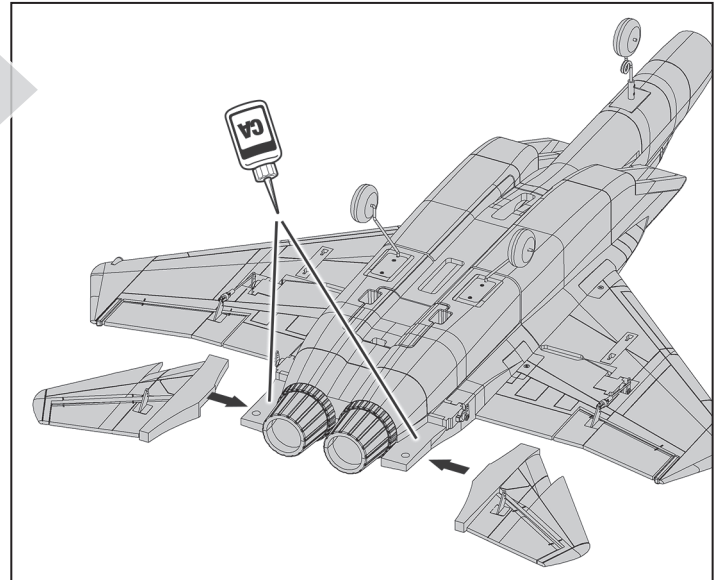
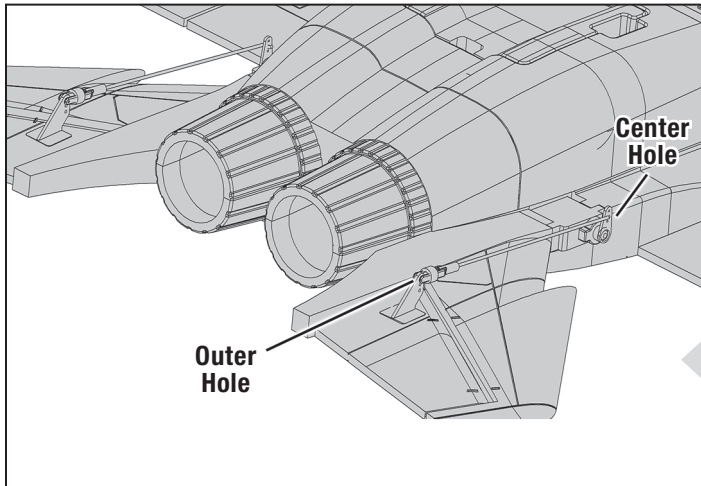

3. On each side, attach the Z-bend of the elevator linkage to the center hole of the servo arm then attach the clevises to the outer hole of the elevator control horns. Slide the clevis retainer tube over the clevis to lock in place.

IMPORTANT! Adjust each pushrod clevis to make sure the travel of both elevators match and are centered.

Vertical Stabilizer Installation

1. Apply medium CA to the base of the vertical stabilizers where they meet the fuselage.
2. Fit the vertical stabilizer in place on the fuselage. Make sure the vertical stabilizers are straight up and down and point straight.

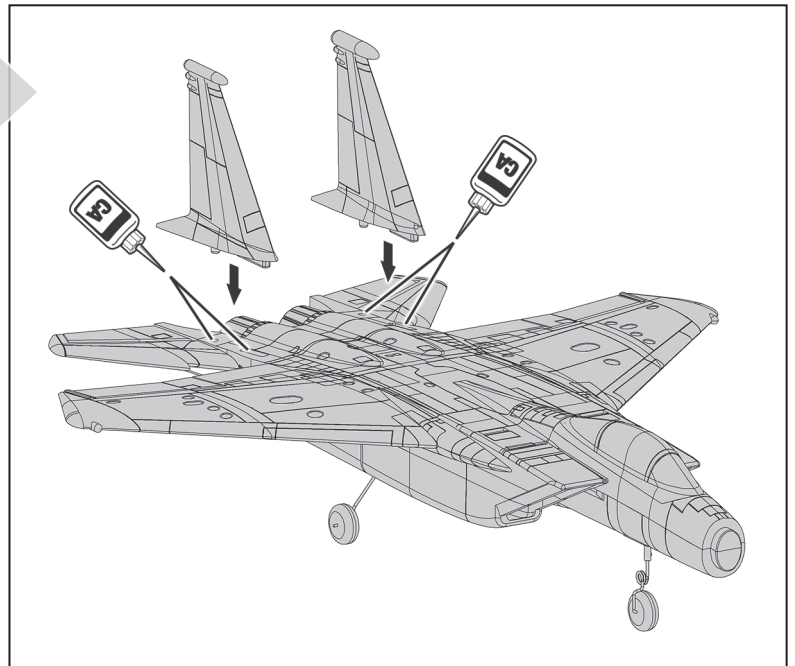

Model Assembly *Continued*

Missile Installation

1. Attach the missiles on each side of the tanks using medium CA glue.

TIP: Along the line where the Missile rack and the Fuel Tank connect, use a T-Pin or Hobby Knife to poke several small holes through the paint to help the glue adhere.

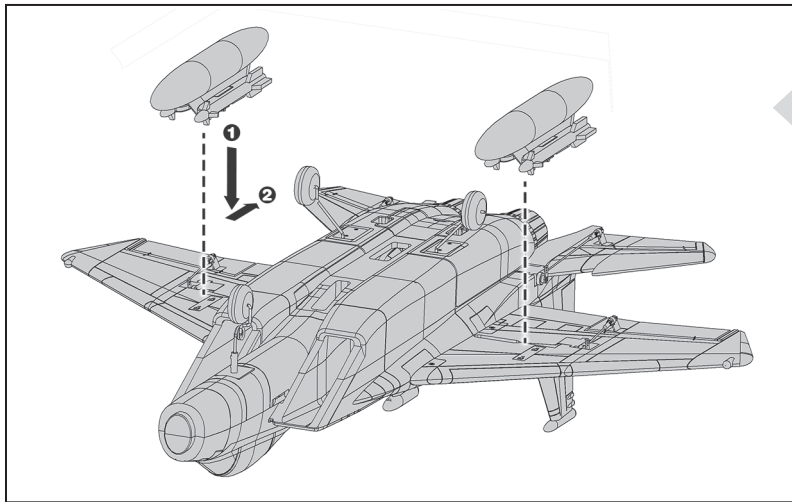
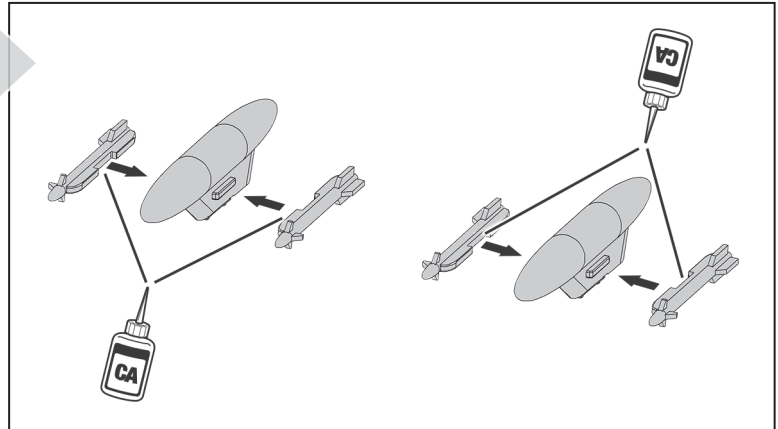

2. Attach a missile assembly onto each wing by placing them into the slot and sliding back to lock in place. Ensure the long area of the tank faces forward. No glue is required.

Nose Cone Installation

1. Attach the nose cone to the airplane. The cone is held in place with the magnet. For a more secure attachment, use medium CA glue.

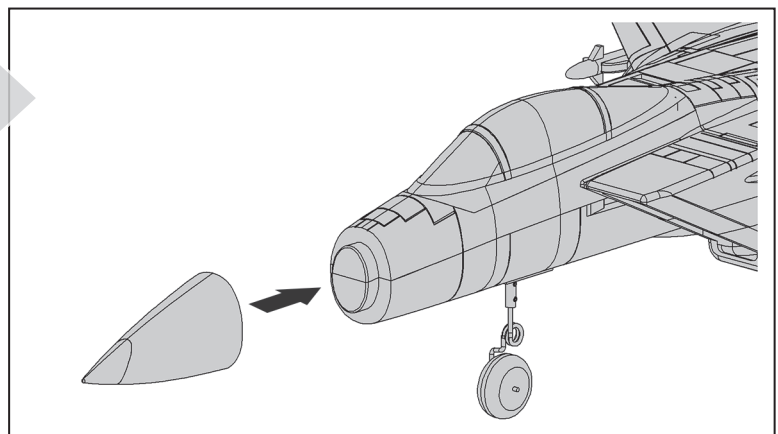

Transmitter and Receiver Binding / Enabling and Disabling SAFE Select (BNF Basic)

This product requires an approved Spektrum™ DSM2®/DSMX® compatible transmitter. Visit www.bindnfly.com for a complete list of approved transmitters.

The aircraft has an optional SAFE Select feature, which can be switched ON or OFF easily by binding in a specific manner as described below.

IMPORTANT: Before binding a transmitter, read the Transmitter Setup section of this manual to ensure that your transmitter is properly programmed for this aircraft.

Bind Plug Installation

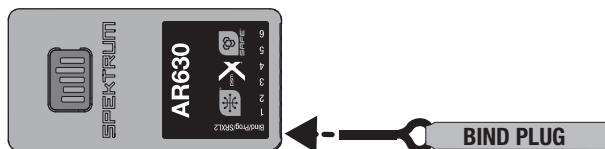

Binding Procedure / Switching ON SAFE Select

IMPORTANT: The included AR630 receiver has been programmed for operation specifically for this aircraft. Refer to the receiver manual for correct setup if the receiver is replaced or is used in another aircraft.

CAUTION: When using a Futaba® transmitter with a Spektrum DSM® module, you must reverse the throttle channel and rebind. Refer to your Spektrum module manual for binding and failsafe instructions. Refer to your Futaba transmitter manual for instructions on reversing the throttle channel.

1. Make sure the transmitter is powered off.
2. Move the transmitter controls to neutral (flight controls: rudder, elevators and ailerons) or to low positions (throttle, throttle trim).*
3. Install a bind plug in the receiver bind port.
4. Place the aircraft level on its wheels, then connect the flight battery to the ESC. The ESC will produce a series of sounds. Three flat tones followed immediately by two ascending tones confirm that the LVC is set correctly for the ESC. The orange bind LED on the receiver will begin to flash rapidly.
5. Remove the bind plug from the bind port.
6. Take three steps away from the aircraft /receiver and then power ON the transmitter while holding the transmitter bind button or switch. Refer to your transmitter's manual for specific binding instructions.
IMPORTANT: Do not point the transmitter's antenna directly at the receiver while binding.
IMPORTANT: Keep away from large metal objects while binding.
7. The receiver is bound to the transmitter when the orange bind light on the receiver stays orange. The ESC will produce a series of sounds. Three or four flat tones followed immediately by two ascending tones. The tones indicate the number of cells in the battery and that the ESC is armed, provided the throttle stick and throttle trim are low enough to trigger arming.

IMPORTANT: Once bound, the receiver will retain its bind settings for that transmitter until it has been intentionally changed, even when power is cycled ON and OFF. Repeat the binding process as necessary.

SAFE Select ON Indication

Every time the receiver is powered ON the surfaces will cycle back and forth **twice** with a slight pause at neutral position to indicate that SAFE Select is switched ON.

The throttle will not arm if the transmitter's throttle control is not put at the lowest position. If problems are encountered, follow the binding instructions and refer to the transmitter troubleshooting guide for other instructions. If needed, contact the appropriate Horizon Product Support office.

*Failsafe

If the receiver loses transmitter communication, the failsafe will activate. When activated, failsafe moves the throttle channel to its preset failsafe position (low throttle) that was set during binding. All other channels move to actively level the aircraft in flight.

Switching ON SAFE Select Binding Sequence

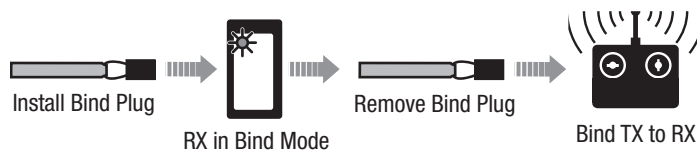

Switching OFF SAFE Select Binding Sequence

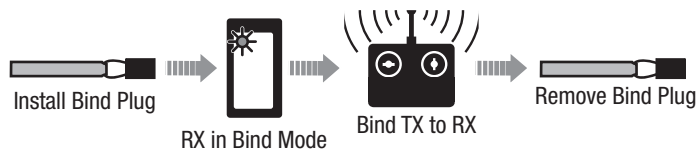

Binding Procedure / Switching OFF SAFE Select

IMPORTANT: The included AR630 receiver has been programmed for operation specifically for this aircraft. Refer to the receiver manual for correct setup if the receiver is replaced or is used in another aircraft.

CAUTION: When using a Futaba® transmitter with a Spektrum DSM® module, you must reverse the throttle channel and rebind. Refer to your Spektrum module manual for binding and failsafe instructions. Refer to your Futaba transmitter manual for instructions on reversing the throttle channel.

1. Make sure the transmitter is powered off.
2. Move the transmitter controls to neutral (flight controls: rudder, elevators and ailerons) or to low positions (throttle, throttle trim).*
3. Install a bind plug in the receiver bind port.
4. Place the aircraft level on its wheels, then connect the flight battery to the ESC. The ESC will produce a series of sounds. Three flat tones followed immediately by two ascending tones confirm that the LVC is set correctly for the ESC.
The orange bind LED on the receiver will begin to flash rapidly. DO NOT remove the bind plug at this time.
5. Take three steps away from the aircraft /receiver and then power ON the transmitter while holding the transmitter bind button or switch. Refer to your transmitter's manual for specific binding instructions.
IMPORTANT: Do not point the transmitter's antenna directly at the receiver while binding.
IMPORTANT: Keep away from large metal objects while binding.
6. The receiver is bound to the transmitter when the orange bind light on the receiver stays orange. The ESC will produce a series of sounds. Three or four flat tones followed immediately by two ascending tones. The tones indicate the number of cells in the battery and that the ESC is armed, provided the throttle stick and throttle trim are low enough to trigger arming.

7. Remove the bind plug from the bind port.

IMPORTANT: Once bound, the receiver will retain its bind settings for that transmitter until it has been intentionally changed, even when power is cycled ON and OFF. Repeat the binding process as necessary.

SAFE Select OFF Indication

Every time the receiver is powered ON the surfaces will cycle back and forth **once** to indicate that SAFE Select has been switched OFF.

The throttle will not arm if the transmitter's throttle control is not put at the lowest position. If problems are encountered, follow the binding instructions and refer to the transmitter troubleshooting guide for other instructions. If needed, contact the appropriate Horizon Product Support office.

PNP Receiver Selection and Installation

The Spektrum™ AR630 receiver is recommended for this airplane. If you choose to install another receiver, ensure that it is at least a 6-channel full range receiver. Refer to your receiver manual for correct installation and operation instructions.

Installation (AR630 shown)

1. Mount the receiver using double-sided servo tape. The receiver may be mounted upright, upside down or on its side, but it should be square with the fuselage in its mounting position. The receiver cannot be mounted at an odd angle.

TIP: For SAFE setups, install the receiver as close to the center of gravity of the aircraft as practical.

2. Connect the servos to their respective ports on the receiver using the chart below.



CAUTION: Incorrect installation of the receiver could cause a crash. Always perform a control surface check and AS3X control surface response test before flying a new setup, or after any setup changes.

IMPORTANT: When using Y-harness or servo extensions with Spektrum equipment, do not use reversing harnesses. Using reversing Y-harnesses or servo extensions may cause servos to operate erratically or not function at all.

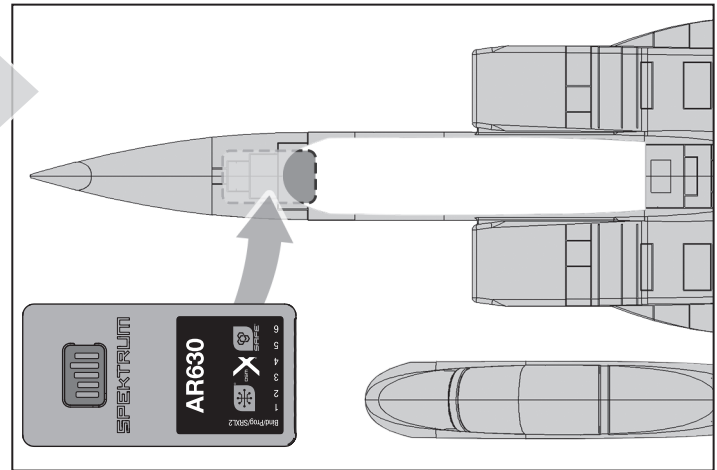

AR630 Port Assignments

Bind/Prog/SRXL2= Bind, Aux Device Support, Program

- | | |
|-----------------------------|----------|
| 1 Throttle (Smart Throttle) | 4 Rudder |
| 2 Aileron | 5 Gear |
| 3 Elevator | 6 Aux 1 |

Transmitter and Receiver Binding

Programming the AR630 receiver requires a Spektrum™ DSM2®/DSMX® compatible transmitter with Forward Programming. Forward programming is only available in DSMX.

Binding

The AR630 receiver must be bound to your transmitter before it will operate. Binding is the process of teaching the receiver the specific code of the transmitter so it will only connect to that specific transmitter.

1. Push and hold the bind button on the receiver while turning the receiver on. Release the bind button once the orange LED starts to flash continuously, indicating the receiver is in bind mode.

TIP: It is still possible to use a bind plug in the bind port if desired. This can come in handy if the receiver needs to be mounted in a location that is difficult to access, in which case a servo extension may be used for binding. If using a bind plug, remove after binding to prevent the system from entering bind mode the next time the power is turned on.

2. Put your transmitter in bind mode.
3. The bind process is complete when the orange LED on the receiver is solid.

Failsafe

In the unlikely event the radio link is lost during use, the receiver will enable the selected failsafe mode. Smart Safe + Hold Last is the default failsafe mode on the AR630. Preset Failsafe and SAFE Failsafe modes are only available through Forward Programming.

SmartSafe + Hold Last

If loss of signal occurs, SmartSafe™ technology moves the throttle channel to the failsafe position (low throttle) set during binding. All other channels will hold their last position. When the receiver detects the signal from the transmitter, normal aircraft operation resumes.

Preset Failsafe

With preset failsafe, you can set the specific control surface positions you want to use if the signal is lost. When the receiver detects the signal from the transmitter, normal aircraft operation resumes. Preset failsafe mode is only available through Forward Programming.

SAFE® Failsafe

SAFE Failsafe mode will work to automatically level your aircraft if the signal is lost. In the forward programming menu you can select the bank and pitch angles the aircraft will attempt to maintain during failsafe. We recommend setting bank and pitch angles so the aircraft flies a gentle gliding turn, preventing a flyaway. You must complete First Time SAFE Setup before this option is available.

SAFE Failsafe mode is only available through Forward Programming.

Testing Failsafe

Secure the aircraft on the ground. Test Failsafe settings by turning the transmitter RF output off and noting how the receiver drives the control surfaces.

Receiver Power Only

- The servo ports will not have a control signal if the receiver is turned on when no transmitter signal is present.
- All channels have no output until the receiver has linked to the transmitter.

Battery Installation and ESC Arming

Battery Selection

We recommend the Spektrum™ 2200mAh 3S 14.8V 30C LiPo battery (SPMX22003S30), for standard operation. The ESC and motor system are designed for both 3S and 4S LiPo batteries. If using a different battery, the battery should be of similar capacity, dimensions and weight of the Spektrum LiPo battery pack. Always be sure the model balances at the recommended CG with the battery chosen.

1. Apply the loop side (soft side) of the hook and loop tape (A) to the bottom of your battery.
2. Install a small piece of the Hook side of the hook and loop inside the fuselage where the battery will sit. Don't make this too big or the battery will be difficult to remove.
3. Carefully lift the back of the canopy hatch (B) to remove.
4. Install the fully charged battery in the battery compartment as shown. See the Adjusting the Center of Gravity instructions for more information.
5. Make sure the flight battery is secured.
6. Lower the throttle and throttle trim to the lowest settings. Power on the Transmitter, then wait 5 seconds.
7. Connect the battery to the ESC (C) (the ESC is now armed).
8. Keep the aircraft immobile and away from wind or the system will not initialize.

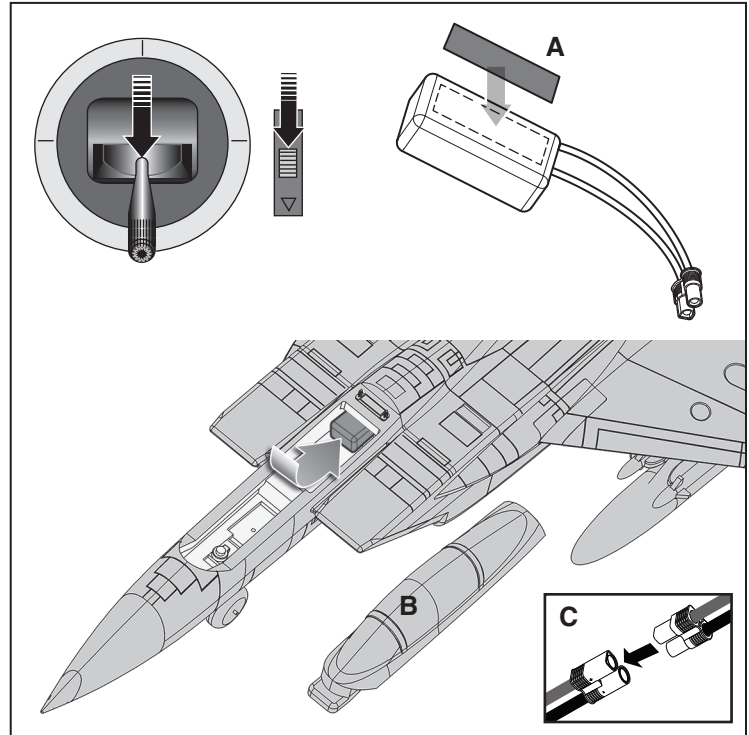

The ESC will sound a series of tones. If the ESC sounds a continuous double beep after the flight battery is connected, recharge or replace the battery.

9. Reinstall the canopy hatch.

SAFE® Select Switch Designation

SAFE® Select technology can be easily assigned to any open switch (two or three position) on the transmitter. With this feature, you now have the flexibility to switch the SAFE feature on and off while in flight.

IMPORTANT: Before assigning your desired switch, ensure that the travel for that channel is set at 100% in both direction.

Assigning a switch

1. Bind the aircraft correctly to activate SAFE Select. This will allow the system to be assigned to a switch.
2. Hold both transmitter sticks to the inside bottom corners and toggle the desired switch five times (one toggle = full up and down) to assign that switch. The control surfaces of the aircraft will move, indicating the switch has been selected.

Repeat the process to assign a different switch if desired. If no switch is assigned, SAFE will be active at all times.

TIP: SAFE Select is assignable on any unused Channels 5–9

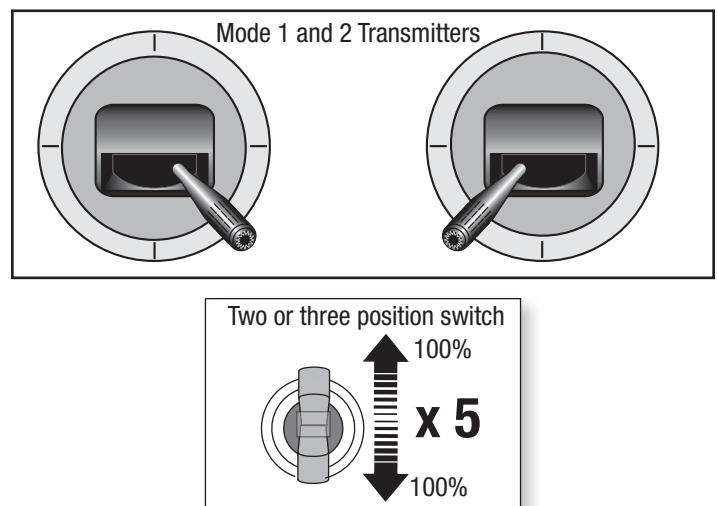

Clevis Installation and Control Centering

Clevis Adjustment

- Slide the clevis retainer off of the clevis to adjust the position on the control horn.
- Carefully spread the clevis, then insert the clevis pin into the desired hole in the control horn.
- Slide the clevis retainer back onto the clevis to secure the clevis to the control horn.

Control Surface Centering

After assembly and transmitter setup, confirm that the control surfaces are centered. If the control surfaces are not centered, mechanically center the control surfaces by adjusting the linkages.

If adjustment is required, turn the clevis on the linkage to change the length of the linkage between the servo arm and the control horn.

After binding a transmitter to the aircraft receiver, set the trims and sub-trims to 0, then adjust the clevises to center the control surfaces.

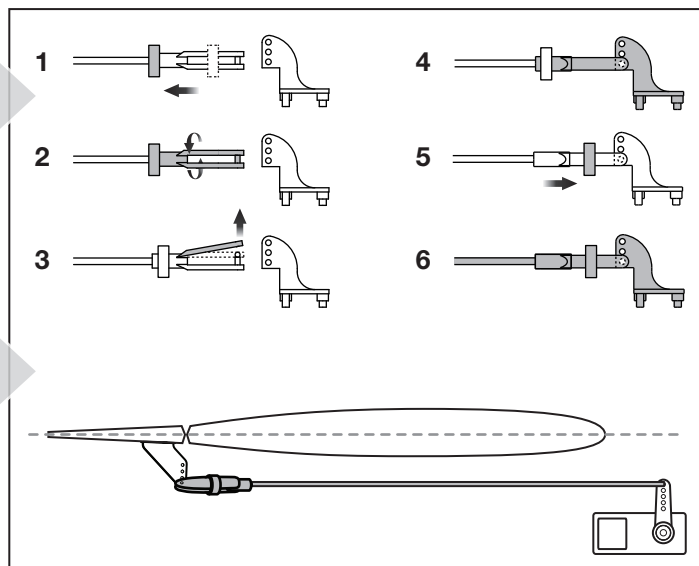

Control Horn and Servo Arm Settings

The table to the right shows the factory settings for the control horns and servo arms. Fly the aircraft at factory settings before making changes.

NOTICE: If control throws are changed from the factory settings, the gain values may need to be adjusted. Refer to your receiver manual for adjustment of gain values.

After flying, you may choose to adjust the linkage positions for the desired control response. See the table to the right.

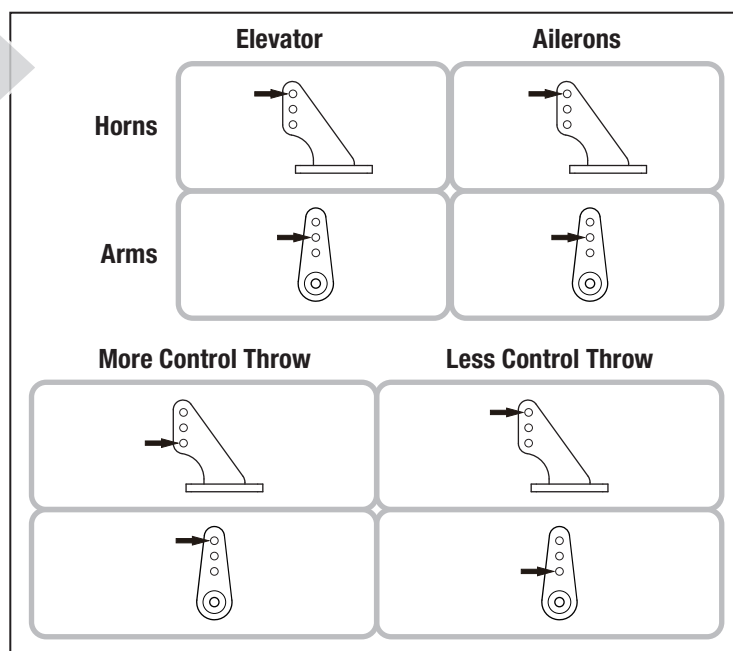

Center of Gravity (CG)

The CG location is measured from the leading edge of the wing at the root. This CG location has been determined with the recommended Li-Po battery (SPMX22004S40).

The battery can be moved forward or back to adjust the CG.

NOTICE: Install the battery but do not arm the ESC while checking the CG. Personal injury may result.

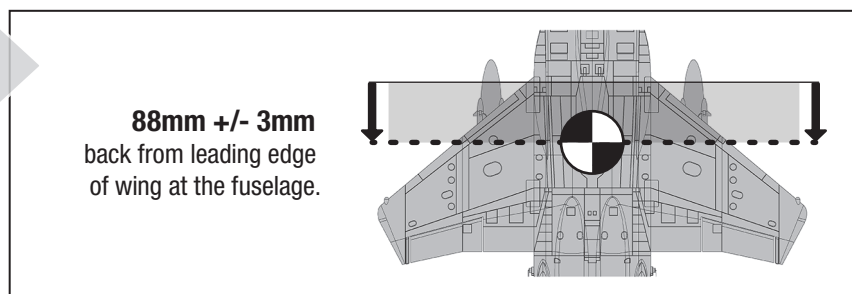

Control Surface Direction

Ailerons

Switch on the transmitter and connect the battery. Use the transmitter to operate the ailerons. View the aircraft from the rear when checking the control directions.

1. Move the right stick to the left. The left aileron will move up and the right aileron move down, causing the aircraft to bank left.
2. Move the right stick to the right. The left aileron will move down and the right aileron move up, causing the aircraft to bank right.

Elevators

3. Move the right stick toward the bottom of the transmitter. The elevators will move up, causing the aircraft to climb.
4. Move the right stick toward the top of the transmitter. The elevators will move down, causing the aircraft to pitch down.

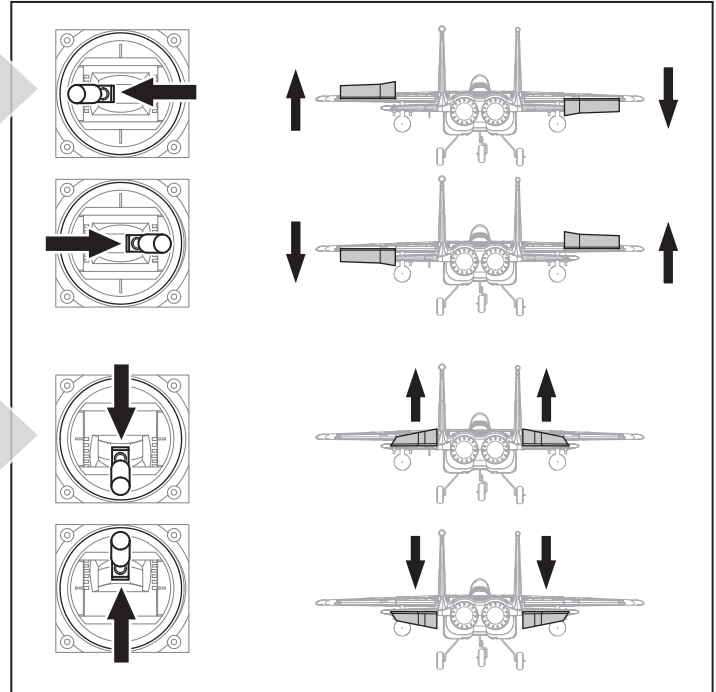

AS3X Control Direction Test (BNF Basic)

This test ensures that the AS3X® control system is functioning properly. Assemble the aircraft and bind your transmitter to the receiver before performing this test.

1. Hold the aircraft and raise the throttle just above 25%, then lower the throttle to activate AS3X technology.



CAUTION: Keep all body parts, hair and loose clothing away from the aircraft, as these items could become entangled.

2. Move the entire aircraft as shown and ensure the control surfaces move in the direction indicated in the graphic. If the control surfaces do not respond as shown, do not fly the aircraft. Check receiver orientation and AS3X programming.

Once the AS3X system is active, control surfaces may move rapidly. This is normal. AS3X remains active until the battery is disconnected.

| | Aircraft Movement | AS3X Reaction |
|-----------------|-------------------|---------------|
| ELEVATOR | | |
| | | |
| AILERON | | |
| | | |

In Flight Trimming (BNF Basic)

During your first flight, trim the aircraft for level flight at 3/4 throttle. Make small trim adjustments with your transmitter's trim switches to straighten the aircraft's flight path.

After adjusting the trim, do not touch the control sticks for 3 seconds. This allows the receiver to learn the correct settings to optimize AS3X performance.

Failure to do so could affect flight performance.

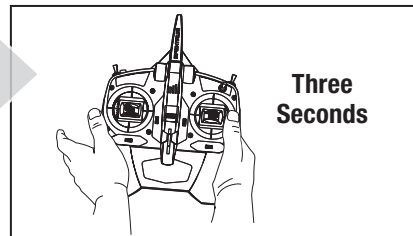

Flying Tips and Repairs

Consult local laws and ordinances before choosing a flying location.

Range Check your Radio System

Before you fly, range check the radio system. Refer to your specific transmitter instruction manual for range test information.

Oscillation

Once the AS3X system is active (after advancing the throttle for the first time), you will normally see the control surfaces react to aircraft movement. In some flight conditions you may see oscillation (the aircraft rocks back and forth on one axis due to overcontrol). If oscillation occurs, refer to the Troubleshooting Guide for more information.

Takeoff

Place the aircraft facing into the wind. Set your transmitter in low rate. Gradually increase the throttle to 3/4 and steer with the rudder. As the plane reaches flying speed, pull back gently on the elevator. When airborne, climb to a comfortable altitude.

Flying

For your first flights with the recommended battery pack (EFLB22003S30), set your transmitter timer or a stopwatch to 3 minutes. After three minutes, land the aircraft. Adjust your timer for longer or shorter flights once you have flown the model. If at any time the motor power reduces, land the aircraft immediately to recharge the flight battery. See the Low Voltage Cutoff (LVC) section for more details on maximizing battery health and run time.

Landing

Land the aircraft into the wind. Use a small amount of throttle for the entire descent. Lower the throttle to 1/4.

Keep the throttle on until the aircraft is ready to flare. During flare, keep the wings level and the aircraft pointed into the wind. Gently lower the throttle while pulling back on the elevator to bring the aircraft down on its wheels.

Once on the ground, avoid sharp turns until the plane has slowed enough to prevent scraping the wingtips.

NOTICE: If a crash is imminent, reduce the throttle. Failure to do so could result in extra damage to the airframe, as well as damage to the ESC and motor.

NOTICE: After any impact, always ensure the receiver is secure in the fuselage. If you replace the receiver, install the new receiver in the same orientation as the original receiver or damage may result.

NOTICE: Crash damage is not covered under warranty.

NOTICE: When you are finished flying, never leave the aircraft in direct sunlight or in a hot, enclosed area such as a car. Doing so can damage the aircraft.

Low Voltage Cutoff (LVC)

When a Li-Po battery is discharged below 3V per cell, it will not hold a charge. The ESC protects the flight battery from over-discharge using Low Voltage Cutoff (LVC). Before the battery charge decreases too much, LVC reduces power supplied to the motor showing that some battery power is low but there is still enough reserved for flight control and safe landing.

Disconnect and remove the Li-Po battery from the aircraft after use to prevent trickle discharge. Charge your Li-Po battery to about half capacity before long storage. During storage, make sure the battery charge never falls below 3V per cell. LVC does not prevent the battery from over-discharge during storage.

NOTICE: Repeated flying to LVC will damage the battery.

TIP: Monitor your aircraft battery's voltage before and after flying by using a Li-Po Cell Voltage Checker (SPMXBC100, sold separately).

Repairs

Thanks to the EPO foam material in this aircraft, repairs to the foam can be made using virtually any adhesive (hot glue, regular CA, epoxy, etc). When parts are not repairable, see the Replacement Parts List for ordering by item number. For a listing of all replacement and optional parts, refer to the list at the end of this manual.

NOTICE: Use of CA accelerant on your aircraft can damage paint. DO NOT handle the aircraft until accelerant fully dries.

Post Flight

1. Disconnect the flight battery from the ESC (Required for Safety and battery life).
2. Power OFF the transmitter.
3. Remove the flight battery from the aircraft.
4. Recharge the flight battery.

5. Repair or replace all damaged parts.
6. Store the flight battery apart from the aircraft and monitor the battery charge.
7. Make note of the flight conditions and flight plan results, planning for future flights.

Power Components Service



CAUTION: Always disconnect the flight battery before performing motor service.

Disassembly

1. Carefully remove the lower cover to gain access to the ESC. It is held on with flexible glue that can be gently pulled away.
2. Disconnect the motor connectors from the ESC.
3. To access the motor/fan unit, remove the two screws (one on each side).
4. Disassemble the motor/fan as needed.
 - Assembly in reverse order.
 - Make sure the spinner is fully seated on the fan blade for safe operation.
 - Make sure you match the colors on the ESC wires with the colors on the motor.

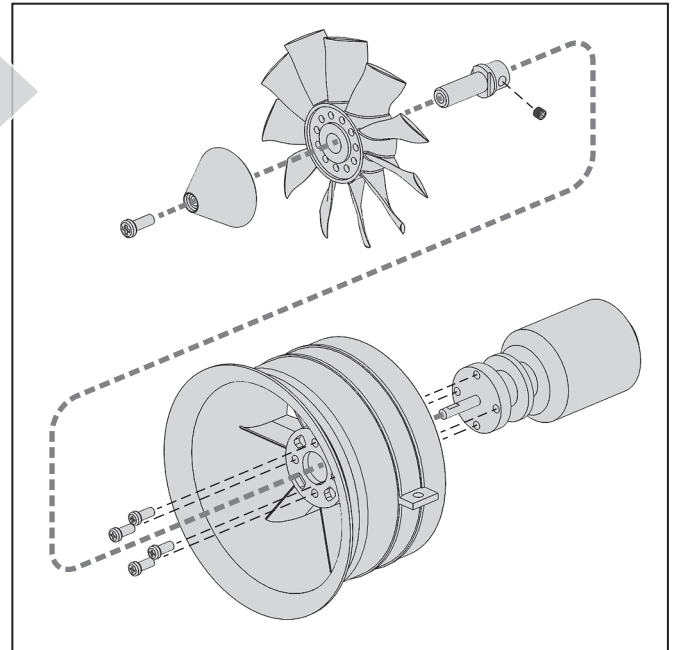

Troubleshooting Guide AS3X

| Problem | Possible Cause | Solution |
|---|---|--|
| Oscillation | Motor vibration | Replace parts or correctly align all parts and tighten fasteners as needed |
| | Loose receiver | Align and secure receiver in fuselage |
| | Loose aircraft controls | Tighten or otherwise secure parts (servo, arm, linkage, horn and control surface) |
| | Worn parts | Replace worn parts (especially propeller, spinner or servo) |
| | Irregular servo movement | Replace servo |
| Inconsistent flight performance | Trim is not at neutral | If you adjust trim more than 8 clicks, adjust the clevis to remove trim |
| | Sub-Trim is not at neutral | No Sub-Trim is allowed. Adjust the servo linkage |
| | Aircraft was not kept immobile for 5 seconds after battery connection | With the throttle stick in lowest position. Disconnect battery, then reconnect battery and keep the aircraft still for 5 seconds |
| Incorrect response to the AS3X Control Direction Test | Incorrect direction settings in the receiver, which can cause a crash | DO NOT fly. Correct the direction settings using a AS3X programmer |

Troubleshooting Guide

| Problem | Possible Cause | Solution |
|--|--|---|
| Aircraft will not respond to throttle but responds to other controls | Throttle not at idle and/or throttle trim too high | Reset controls with throttle stick and throttle trim at lowest setting |
| | Throttle servo travel is lower than 100% | Make sure throttle servo travel is 100% or greater |
| | Throttle channel is reversed | Reverse throttle channel on transmitter |
| | Motor disconnected from ESC | Make sure motor is connected to the ESC |
| Extra noise or extra vibration during throttle operation | Damaged rotor, collet or motor | Replace damaged parts |
| | Rotor is out of balance | Balance or replace rotor |
| | Rotor nut is too loose | Tighten the rotor nut |
| Reduced flight time or aircraft underpowered | Flight battery charge is low | Completely recharge flight battery |
| | Flight battery damaged | Replace flight battery and follow flight battery instructions |
| | Flight conditions may be too cold | Make sure battery is warm before use |
| | Battery capacity too low for flight conditions | Replace battery or use a larger capacity battery |
| Aircraft will not connect (during binding) to transmitter | Transmitter too near aircraft during binding process | Move powered transmitter a few feet from aircraft, disconnect and reconnect flight battery to aircraft |
| | Aircraft or transmitter is too close to large metal object, wireless source or another transmitter | Move aircraft and transmitter to another location and attempt binding again |
| | Flight battery/transmitter battery charge is too low | Replace/recharge batteries |
| | Bind switch or button not held long enough during bind process | Power off transmitter and repeat bind process. Hold transmitter bind button or switch until receiver is bound |
| Aircraft will not connect (after binding) to transmitter | Transmitter too near aircraft during connecting process | Move powered transmitter a few feet from aircraft, disconnect and reconnect flight battery to aircraft |
| | Aircraft or transmitter is too close to large metal object, wireless source or another transmitter | Move aircraft and transmitter to another location and attempt connecting again |
| | Aircraft bound to different model memory (ModelMatch™ radios only) | Select correct model memory on transmitter |
| | Flight battery/Transmitter battery charge is too low | Replace/recharge batteries |
| | Transmitter may have been bound to a different aircraft using different DSM protocol | Bind aircraft to transmitter |
| Control surface does not move | Control surface, control horn, linkage or servo damage | Replace or repair damaged parts and adjust controls |
| | Wire damaged or connections loose | Do a check of wires and connections, connect or replace as needed |
| | Transmitter is not bound correctly or the incorrect airplanes was selected | Re-bind or select correct airplanes in transmitter |
| | Flight battery charge is low | Fully recharge flight battery |
| | BEC (Battery Elimination Circuit) of the ESC is damaged | Replace ESC |
| Controls reversed | Transmitter settings are reversed | Perform the Control Direction Test and adjust the controls on the transmitter appropriately |
| Motor power pulses then motor loses power | ESC uses default soft Low Voltage Cutoff (LVC) | Recharge flight battery or replace battery that is no longer performing |
| | Weather conditions might be too cold | Postpone flight until weather is warmer |
| | Battery is old, worn out, or damaged | Replace battery |
| | Battery C rating might be too small | Use recommended battery |

AMA National Model Aircraft Safety Code

Academy of Model Aeronautics National Model Aircraft Safety Code

Effective January 1, 2018

A model aircraft is a non-human-carrying device capable of sustained flight within visual line of sight of the pilot or spotter(s). It may not exceed limitations of this code and is intended exclusively for sport, recreation, education and/or competition. All model flights must be conducted in accordance with this safety code and related AMA guidelines, any additional rules specific to the flying site, as well as all applicable laws and regulations.

As an AMA member I agree:

- I will not fly a model aircraft in a careless or reckless manner.
- I will not interfere with and will yield the right of way to all human-carrying aircraft using AMA's See and Avoid Guidance and a spotter when appropriate.
- I will not operate any model aircraft while I am under the influence of alcohol or any drug that could adversely affect my ability to safely control the model.
- I will avoid flying directly over unprotected people, moving vehicles, and occupied structures.
- I will fly Free Flight (FF) and Control Line (CL) models in compliance with AMA's safety programming.
- I will maintain visual contact of an RC model aircraft without enhancement other than corrective lenses prescribed to me. When using an advanced flight system, such as an autopilot, or flying First-Person View (FPV), I will comply with AMA's Advanced Flight System programming.
- I will only fly models weighing more than 55 pounds, including fuel, if certified through AMA's Large Model Airplane Program.
- I will only fly a turbine-powered model aircraft in compliance with AMA's Gas Turbine Program.
- I will not fly a powered model outdoors closer than 25 feet to any individual, except for myself or my helper(s) located at the flightline, unless I am taking off and landing, or as otherwise provided in AMA's Competition Regulation.
- I will use an established safety line to separate all model aircraft operations from spectators and bystanders.

Limited Warranty

What this Warranty Covers

Horizon Hobby, LLC, (Horizon) warrants to the original purchaser that the product purchased (the "Product") will be free from defects in materials and workmanship at the date of purchase.

What is Not Covered

This warranty is not transferable and does not cover (i) cosmetic damage, (ii) damage due to acts of God, accident, misuse, abuse, negligence, commercial use, or due to improper use, installation, operation or maintenance, (iii) modification of or to any part of the Product, (iv) attempted service by anyone other than a Horizon Hobby authorized service center, (v) Product not purchased from an authorized Horizon dealer, or (vi) Product not compliant with applicable technical regulations, or (vii) use that violates any applicable laws, rules, or regulations.

OTHER THAN THE EXPRESS WARRANTY ABOVE, HORIZON MAKES NO OTHER WARRANTY OR REPRESENTATION, AND HEREBY DISCLAIMS ANY AND ALL IMPLIED WARRANTIES, INCLUDING, WITHOUT LIMITATION, THE IMPLIED WARRANTIES OF NON-INFRINGEMENT, MERCHANTABILITY AND FITNESS FOR A PARTICULAR PURPOSE. THE PURCHASER ACKNOWLEDGES THAT THEY ALONE HAVE DETERMINED THAT THE PRODUCT WILL SUITABLY MEET THE REQUIREMENTS OF THE PURCHASER'S INTENDED USE.

Purchaser's Remedy

Horizon's sole obligation and purchaser's sole and exclusive remedy shall be that Horizon will, at its option, either (i) service, or (ii) replace, any Product determined by Horizon to be defective. Horizon reserves the right to inspect any and all Product(s) involved in a warranty claim. Service or replacement decisions are at the sole discretion of Horizon. Proof of purchase is required for all warranty claims. SERVICE OR REPLACEMENT AS PROVIDED UNDER THIS WARRANTY IS THE PURCHASER'S SOLE AND EXCLUSIVE REMEDY.

Limitation of Liability

HORIZON SHALL NOT BE LIABLE FOR SPECIAL, INDIRECT, INCIDENTAL OR CONSEQUENTIAL DAMAGES, LOSS OF PROFITS OR PRODUCTION OR COMMERCIAL LOSS IN ANY WAY, REGARDLESS OF WHETHER SUCH CLAIM IS BASED IN CONTRACT, WARRANTY, TORT, NEGLIGENCE, STRICT LIABILITY OR ANY OTHER THEORY OF LIABILITY, EVEN IF HORIZON HAS BEEN ADVISED OF THE POSSIBILITY OF SUCH DAMAGES. Further, in no event shall the liability of Horizon exceed the individual price of the Product on which liability is asserted. As Horizon has no control over use, setup, final assembly, modification or misuse, no liability shall be assumed nor accepted for any resulting damage or injury. By the act of use, setup or assembly, the user accepts all resulting liability. If you as the purchaser or user are not prepared to accept the liability associated with the use of the Product, purchaser is advised to return the Product immediately in new and unused condition to the place of purchase.

Law

These terms are governed by Illinois law (without regard to conflict of law principals). This warranty gives you specific legal rights, and you may also have other rights which vary from state to state. Horizon reserves the right to change or modify this warranty at any time without notice.

WARRANTY SERVICES

Questions, Assistance, and Services

Your local hobby store and/or place of purchase cannot provide warranty support or service. Once assembly, setup or use of the Product has been started, you must contact your local distributor or Horizon directly. This will enable Horizon to better answer your questions and service you in the event that you may need any assistance. For questions

or assistance, please visit our website at www.horizonhobby.com, submit a Product Support Inquiry, or call the toll free telephone number referenced in the Warranty and Service Contact Information section to speak with a Product Support representative.

Inspection or Services

If this Product needs to be inspected or serviced and is compliant in the country you live and use the Product in, please use the Horizon Online Service Request submission process found on our website or call Horizon to obtain a Return Merchandise Authorization (RMA) number. Pack the Product securely using a shipping carton. Please note that original boxes may be included, but are not designed to withstand the rigors of shipping without additional protection. Ship via a carrier that provides tracking and insurance for lost or damaged parcels, as Horizon is not responsible for merchandise until it arrives and is accepted at our facility. An Online Service Request is available at http://www.horizonhobby.com/content/_service-center_render-service-center. If you do not have internet access, please contact Horizon Product Support to obtain a RMA number along with instructions for submitting your product for service. When calling Horizon, you will be asked to provide your complete name, street address, email address and phone number where you can be reached during business hours. When sending product into Horizon, please include your RMA number, a list of the included items, and a brief summary of the problem. A copy of your original sales receipt must be included for warranty consideration. Be sure your name, address, and RMA number are clearly written on the outside of the shipping carton.

NOTICE: Do not ship LiPo batteries to Horizon. If you have any issue with a LiPo battery, please contact the appropriate Horizon Product Support office.

Warranty Requirements

For Warranty consideration, you must include your original sales receipt verifying the proof-of-purchase date. Provided warranty conditions have been met, your Product will be serviced or replaced free of charge. Service or replacement decisions are at the sole discretion of Horizon.

Non-Warranty Service

Should your service not be covered by warranty, service will be completed and payment will be required without notification or estimate of the expense unless the expense exceeds 50% of the retail purchase cost. By submitting the item for service you are agreeing to payment of the service without notification. Service estimates are available upon request. You must include this request with your item submitted for service. Non-warranty service estimates will be billed a minimum of ½ hour of labor. In addition you will be billed for return freight. Horizon accepts money orders and cashier's checks, as well as Visa, MasterCard, American Express, and Discover cards. By submitting any item to Horizon for service, you are agreeing to Horizon's Terms and Conditions found on our website http://www.horizonhobby.com/content/_service-center_render-service-center.

ATTENTION: Horizon service is limited to Product compliant in the country of use and ownership. If received, a non-compliant Product will not be serviced. Further, the sender will be responsible for arranging return shipment of the un-serviced Product, through a carrier of the sender's choice and at the sender's expense. Horizon will hold non-compliant Product for a period of 60 days from notification, after which it will be discarded.

Contact Information

| Country of Purchase | Horizon Hobby | Contact Information | Address |
|--------------------------|---|--|--|
| United States of America | Horizon Service Center (Repairs and Repair Requests) | servicecenter.horizonhobby.com/Request-Form/ | 2904 Research Rd Champaign, Illinois, 61822 USA |
| | Horizon Product Support (Product Technical Assistance) | productsupport@horizonhobby.com 877-504-0233 | |
| | Sales | websales@horizonhobby.com 800-338-4639 | |
| European Union | Horizon Technischer Service Sales: Horizon Hobby GmbH | service@horizonhobby.eu +49 (0) 4121 2655 100 | Hanskampring 9 D 22885 Barsbüttel, Germany |

FCC Information

FCC ID: BRWSPMAR630 **Supplier's Declaration of Conformity** F-15 Eagle 64mm EDF PNP/BASIC (EFL97500/EFL9775)

This device complies with part 15 of the FCC Rules. Operation is subject to the following two conditions: (1) This device may not cause harmful interference, and (2) this device must accept any interference received, including interference that may cause undesired operation.

CAUTION: Changes or modifications not expressly approved by the party responsible for compliance could void the user's authority to operate the equipment.

NOTE: This equipment has been tested and found to comply with the limits for a Class B digital device, pursuant to part 15 of the FCC Rules. These limits are designed to provide reasonable protection against harmful interference in a residential installation. This equipment generates, uses and can radiate radio frequency energy and, if not installed and used in accordance with the instructions, may cause harmful interfer-

ence to radio communications. However, there is no guarantee that interference will not occur in a particular installation. If this equipment does cause harmful interference to radio or television reception, which can be determined by turning the equipment off and on, the user is encouraged to try to correct the interference by one or more of the following measures:

- Reorient or relocate the receiving antenna.
- Increase the separation between the equipment and receiver.
- Connect the equipment into an outlet on a circuit different from that to which the receiver is connected.
- Consult the dealer or an experienced radio/TV technician for help.

Horizon Hobby, LLC
2904 Research Rd., Champaign, IL 61822
Email: compliance@horizonhobby.com
Web: HorizonHobby.com

IC Information

IC: 6157A-SPMAR630 CAN ICES-3 (B)/NMB-3(B)

This device contains license-exempt transmitter(s)/receiver(s) that comply with Innovation, Science, and Economic Development Canada's license-exempt RSS(s). Operation is subject to the following 2 conditions:

This device may not cause interference.

This device must accept any interference, including interference that may cause undesired operation of the device.

Compliance Information for the European Union

EU Compliance Statement:
F-15 Eagle 64mm EDF BNF-B (EFL97500) Hereby, Horizon Hobby, LLC declares that the device is in compliance with the following: EU Radio Equipment Directive 2014/53/EU.

F-15 Eagle 64mm EDF PNP (EFL9775) Hereby, Horizon Hobby, LLC declares that the device is in compliance with the following: EU EMC Directive 2014/30/EU.

The full text of the EU declaration of conformity is available at the following internet address: <https://www.horizonhobby.com/content/support-render-compliance>.

Wireless Frequency Range and Wireless Output Power:
2402 – 2478 MHz
4.65dBm

EU Manufacturer of Record:

Horizon Hobby, LLC
2904 Research Road
Champaign, IL 61822 USA

EU Importer of Record:

Horizon Hobby, GmbH
Hanskampring 9
22885 Barsbüttel Germany

WEEE NOTICE:



This appliance is labeled in accordance with European Directive 2012/19/EU concerning waste of electrical and electronic equipment (WEEE). This label indicates that this product should not be disposed of with household waste. It should be deposited at an appropriate facility to enable recovery and recycling.



Replacement Parts • Ersatzteile • Pièces de rechange • Pezzi di ricambio

| Part # Nummer Numéro Codice | Description | Beschreibung | Description | Descrizione |
|------------------------------------|-----------------------------------|---|---|--|
| EFL9776 | Fuselage: F-15 64mm EDF | Rumpf: F-15 64mm EDF | Fuselage : Soufflante électrique F-15 64 mm | Fusoliera: F-15 64 mm EDF |
| EFL9777 | Wing Set: F-15 64mm EDF | Flügelersatz: F-15 64mm EDF | Ensemble d'aile : Soufflante électrique F-15 64 mm | Set ali: F-15 64 mm EDF |
| EFL9778 | Stabilizer Set: F-15 64mm EDF | Stabilisatorsatz: F-15 64mm EDF | Ensemble de stabilisateur : Soufflante électrique F-15 64 mm | Set stabilizzatori: F-15 64 mm EDF |
| EFL9779 | Vertical Fins: F-15 64mm EDF | Stabilisierungsflossen: F-15 64mm EDF | Dérives verticales : Soufflante électrique F-15 64 mm | Derive verticali: F-15 64 mm EDF |
| EFL9780 | Nose Cone: F-15 64mm EDF | Bugspitze: F-15 64mm EDF | Cône de nez : Soufflante électrique F-15 64 mm | Muso: F-15 64 mm EDF |
| EFL9781 | Canopy/Hatch: F-15 64mm EDF | Kanzelabdeckung: F-15 64mm EDF | Verrière/Trappe : Soufflante électrique F-15 64 mm | Tettuccio: F-15 64 mm EDF |
| EFL9782 | Dummy Ordnance: F-15 64mm EDF | Geschoss-Attrappe: F-15 64mm EDF | Matériel de guerre factice : Soufflante électrique F-15 64 mm | Munizionamento simulato: F-15 64 mm EDF |
| EFL9783 | Linkage Rod Set: F-15 64mm EDF | Gestängesatz: F-15 64mm EDF | Ensemble de tige de liaison : Soufflante électrique F-15 64 mm | Set asta di collegamento: F-15 64 mm EDF |
| EFL9784 | Wing Tube: F-15 64mm EDF | Steckungsrohr: F-15 64mm EDF | Tube d'aile : Soufflante électrique F-15 64 mm | Tubo ala: F-15 64 mm EDF |
| EFL9785 | Landing Gear Set: F-15 64mm EDF | Fahrwerksatz: F-15 64mm EDF | Ensemble de train d'atterrissage : Soufflante électrique F-15 64 mm | Set carrello d'atterraggio: F-15 64 mm EDF |
| EFL9786 | Decal Set: F-15 64mm EDF | Decal-Satz: F-15 64mm EDF | Lot d'autocollants : Soufflante électrique F-15 64 mm | Set decalcomanie: F-15 64 mm EDF |
| EFL9787 | Motor: F-15 64mm EDF 2840-3150 Kv | Motor: F-15 64mm EDF 2840-3150Kv | Moteur : Soufflante électrique F-15 64 mm 2 840-3 150 Kv | Motore: F-15 64 mm EDF 2840-3150 Kv |
| EFL9788 | Servo: 9g Positive | Servo: 9 g Positiv | Servo : 9g Positif | Servocomando: 9 g positivo |
| EFL9789 | Servo: 9g Reverse | Servo: 9 g Umkehr | Servo : 9g Inverse | Servocomando: 9 g negativo |
| EFL9790 | Ducted Fan: 64mm EDF Unit | Impeller: 64mm EDF Einheit | Soufflante : Soufflante électrique 64 mm | Ventola intubata: unità 64 mm EDF |
| EFL9791 | ESC: 64mm EDF 40A | Geschwindigkeitsregler: 64mm EDF 40A | Variateur ESC : Soufflante électrique 64 mm 40 A | ESC: 64 mm EDF 40 A |
| EFL9792 | Servo: 9g 54 degree Steering | Servo: 9 g 54-Grad-Lenkung | Servo : Direction 9g 54 degrés | Servocomando: 9 g 54° direzione |
| EFL9793 | Pilot: F-15 Eagle 64mm EDF | Pilot: F-15 Eagle 64mm EDF | Pilote : Soufflante électrique F-15 Eagle 64 mm | Pilota: F-15 Eagle 64 mm EDF |
| SPMAR630 | AR630 6-Ch SAFE and AS3X Receiver | AR630 SAFE und AS3X-Empfänger mit 6 Kanälen | Récepteur AR630 SAFE et AS3X 6 canaux | Ricevitore AR630 SAFE e AS3X a 6 canali |

Optional Parts • Optionale Bauteile • Pièces optionnelles • Pezzi opzionali

| Part # Nummer Numéro Codice | Description | Beschreibung | Description | Descrizione |
|------------------------------------|--------------------------------------|--|---|---|
| SPMR6650 | DX6e 6CH Transmitter Only | Nur DX6e 6CH-Sender | Émetteur DX6e uniquement 6 canaux | Solo trasmittente DX6e 6CH |
| SPMX22003S30 | 2200mAh 3S 11.1V Smart 30C; IC3 | 2200 mAh 3S 11,1 V Smart 30C; IC3 | 2 200 mAh 3S 11,1 V Smart 30 C ; IC3 | 2200 mAh 3S 11,1 V Smart 30C; IC3 |
| SPMX22004S30 | 2200mAh 4S 14.8V Smart 30C; IC3 | 2200 mAh 3S 14,8 V Smart 30C; IC3 | 2 200 mAh 4S 14,8 V Smart 30 C ; IC3 | 2200 mAh 4S 14,8 V Smart 30C; IC3 |
| SPMXC1000 | Smart S1200 DC Charger, 1x200W | Smart S1200 Gleichstrom-Ladegerät, 1x200 W | Chargeur CC Smart S1200, 1x200 W | Caricabatterie Smart S1200 DC, 1x200 W |
| DYNC2030 | Prophet Sport Mini 50W Charger | Prophet Sport Mini 50 W Ladegerät | Chargeur 50 W Prophet Sport Mini | Caricabatterie Prophet Sport Mini 50 W |
| EFLB22003S30 | 2200mAh 3S 11.1V 30C LiPo, 13AWG EC3 | 2200 mAh 3S 11,1 V 30C LiPo, 13AWG EC3 | 2 200 mAh 3S 11,1 V 30 C Li-Po, 13AWG EC3 | Batteria LiPo 2200 mAh 3S 11,1 V 30C, 13AWG EC3 |
| EFLB22004S30 | 2200mAh 4S 14.8V 30C LiPo, 13AWG EC3 | 2200 mAh 4S 14,8 V 30C LiPo, 13AWG EC3 | 2 200 mAh 4S 14,8 V 30 C Li-Po, 13AWG EC3 | Batteria LiPo 2200 mAh 4S 14,8 V 30C, 13AWG EC3 |
| SPMR12000 | iX12 12 Channel Transmitter Only | Nur iX12-Sender mit 12 Kanälen | Émetteur iX12 12 canaux uniquement | Solo trasmittente iX12 12 canali |
| SPMR8100 | DX8e 8CH Transmitter Only | Nur DX8e-Sender mit 8 Kanälen | Émetteur DX8e 8 canaux uniquement | Solo trasmittente DX8e 8 canali |



© 2020 Horizon Hobby, LLC.

E-flite, DSM, DSM2, DSMX, Bind-N-Fly, BNF, the BNF logo, Plug-N-Play, AS3X, SAFE, the SAFE logo, ModelMatch, Prophet, EC3, IC3, and the Horizon Hobby logo are trademarks or registered trademarks of Horizon Hobby, LLC.

The Spektrum trademark is used with permission of Bachmann Industries, Inc.

Futaba is a registered trademark of Futaba Denshi Kogyo Kabushiki Kaisha Corporation of Japan.

All other trademarks, service marks and logos are property of their respective owners.

US 8,672,726. US 9,930,567. US 10,419,970. US 9,056,667. US 9,753,457. US 10,078,329. Other patents pending.

<http://www.e-fliterc.com/>