

Super Decathlon 1.2m

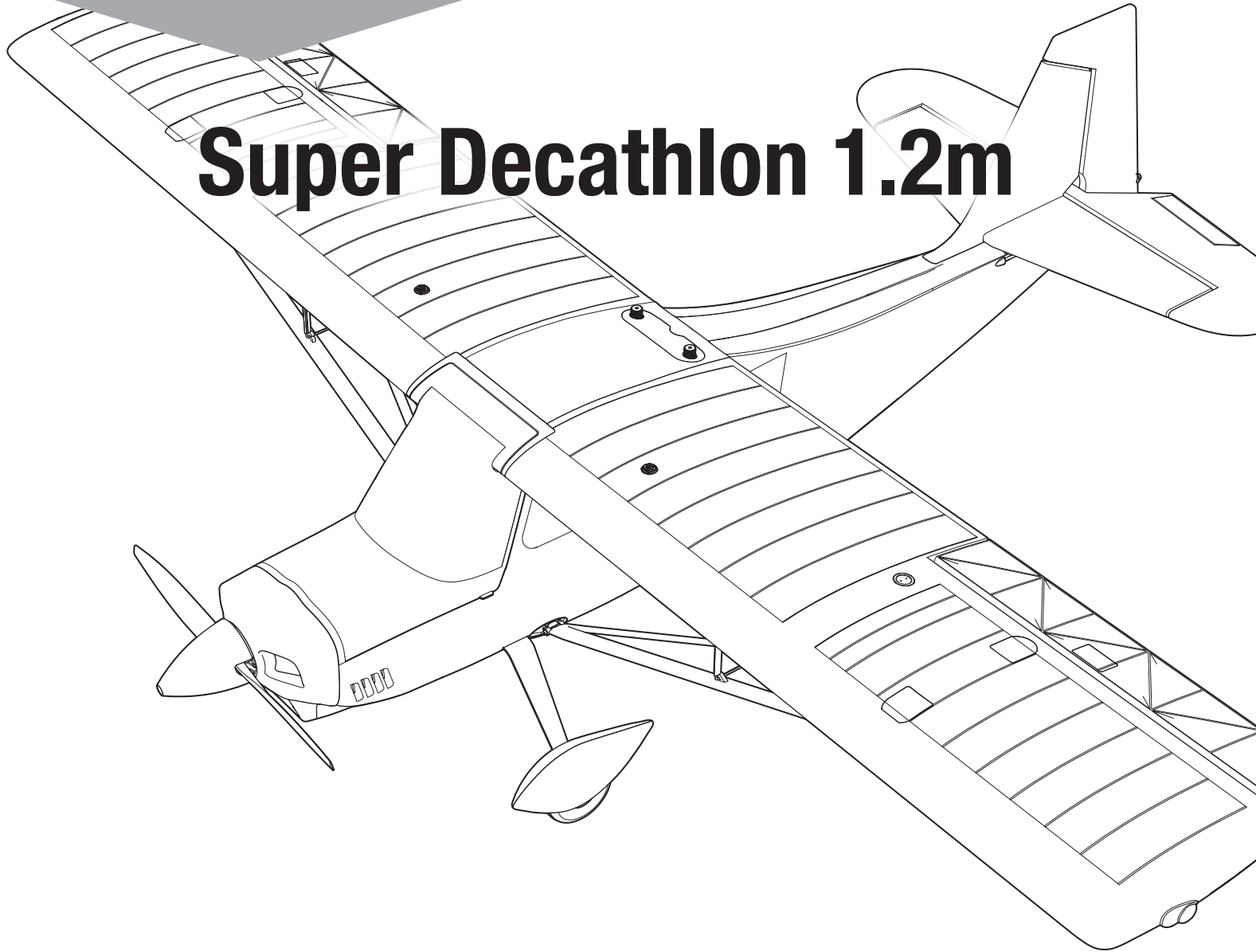

Instruction Manual
Bedienungsanleitung
Manuel d'utilisation
Manuale di Istruzioni

Scan the QR code and select the Manuals and Support quick links from the product page for the most up-to-date manual information.

Scannen Sie den QR-Code und wählen Sie auf der Produktseite die Quicklinks Handbücher und Unterstützung, um die aktuellsten Informationen zu Handbücher.

Scannez le code QR et sélectionnez les liens rapides Manuals and Support sur la page du produit pour obtenir les informations les plus récentes sur le manuel.

Scannerizzare il codice QR e selezionare i Link veloci Manuali e Supporto dalla pagina del prodotto per le informazioni manuali più aggiornate.



EFL20550



EFL20575

NOTICE

All instructions, warranties and other collateral documents are subject to change at the sole discretion of Horizon Hobby, LLC. For up-to-date product literature, visit horizonhobby.com or towerhobbies.com and click on the support or resources tab for this product.

MEANING OF SPECIAL LANGUAGE

The following terms are used throughout the product literature to indicate various levels of potential harm when operating this product:

WARNING: Procedures, which if not properly followed, create the probability of property damage, collateral damage, and serious injury OR create a high probability of superficial injury.

CAUTION: Procedures, which if not properly followed, create the probability of physical property damage AND a possibility of serious injury.

NOTICE: Procedures, which if not properly followed, create a possibility of physical property damage AND little or no possibility of injury.



WARNING: Read the ENTIRE instruction manual to become familiar with the features of the product before operating. Failure to operate the product correctly can result in damage to the product, personal property and cause serious injury.

This is a sophisticated hobby product. It must be operated with caution and common sense and requires some basic mechanical ability. Failure to operate this Product in a safe and responsible manner could result in injury or damage to the product or other property. This product is not intended for use by children without direct adult supervision. Do not use with incompatible components or alter this product in any way outside of the instructions provided by Horizon Hobby, LLC. This manual contains instructions for safety, operation and maintenance. It is essential to read and follow all the instructions and warnings in the manual, prior to assembly, setup or use, in order to operate correctly and avoid damage or serious injury.

AGE RECOMMENDATION: Not for children under 14 years. This is not a toy.

Safety Precautions and Warnings

As the user of this product, you are solely responsible for operating in a manner that does not endanger yourself and others or result in damage to the product or the property of others.

- Always keep a safe distance in all directions around your model to avoid collisions or injury. This model is controlled by a radio signal subject to interference from many sources outside your control. Interference can cause momentary loss of control.
- Always operate your model in open spaces away from full-size vehicles, traffic and people.
- Always carefully follow the directions and warnings for this and any optional support equipment (chargers, rechargeable battery packs, etc.).
- Always keep all chemicals, small parts and anything electrical out of the reach of children.
- Always avoid water exposure to all equipment not specifically designed and protected for this purpose. Moisture causes damage to electronics.
- Never place any portion of the model in your mouth as it could cause serious injury or even death.
- Never operate your model with low transmitter batteries.
- Always keep aircraft in sight and under control.
- Always use fully charged batteries.
- Always keep transmitter powered on while aircraft is powered.
- Always remove batteries before disassembly.
- Always keep moving parts clean.
- Always keep parts dry.
- Always let parts cool after use before touching.
- Always remove batteries after use.
- Always ensure failsafe is properly set before flying.
- Never operate aircraft with damaged wiring.
- Never touch moving parts.



WARNING AGAINST COUNTERFEIT PRODUCTS: If you ever need to replace your Spektrum receiver found in a Horizon Hobby product, always purchase from Horizon Hobby, LLC or a Horizon Hobby authorized dealer to ensure authentic high-quality Spektrum product. Horizon Hobby, LLC disclaims all support and warranty with regards, but not limited to, compatibility and performance of counterfeit products or products claiming compatibility with DSM or Spektrum technology.

Registration

Register your product today to join our mailing list and keep up to date with product updates, offers and E-flite® news.



Table of Contents

Required Tools	3
SAFE® Select Technology (BNF Basic)	4
Smart® Transmitter Setup	4
Manual Transmitter Setup	4
Model Assembly	6
PNP Receiver Selection and Installation	11
Battery Installation and ESC Arming	12
Center of Gravity (CG)	13
Remote Bind Port (BNF Basic)	13
General Binding Tips and Failsafe	14
Transmitter and Receiver Binding / Enable or Disable SAFE Select	14
SAFE® Select Switch Designation (BNF)	15
Control Direction Test.....	16
AS3X+ Response Test.....	17
Control Surface Centering and Adjusting a Ball Link	17
Control Horn and Servo Arm Factory Settings.....	18
Dual Rates and Control Throws	18
SAFE Select Flying Tips (BNF)	18
In-Flight Trimming.....	18
Post Flight.....	19
Thrust Reversing (<i>Optional</i>).....	19
Motor Service	20
Servo Service	20
Troubleshooting Guide AS3X+.....	20
Troubleshooting Guide	21
Replacement Parts.....	22
Recommended Items.....	22
Optional Parts	22
Hardware List	22
Important Federal Aviation Administration (FAA) Information	23
AMA National Model Aircraft Safety Code	23
Limited Warranty	24
Contact Information	24
FCC Information.....	25
IC Information.....	25
Compliance Information for the European Union.....	25

Specifications

Wingspan	47.7" (1212mm)
Length	34.64" (880mm)
Weight	Without Battery: 39oz (1106g) With Recommended 4S 2200mAh Flight Battery: 46.77oz (1326g)

Included Equipment

Receiver*	Spektrum™ AR631+ 6CH AS3X+®/SAFE® Receiver (SPM-1031)
ESC	Avian 45-Amp Smart® Lite Brushless ESC, 3S-4S IC3 (SPMXAE45A)
Motor	Brushless Outrunner Motor; 3536-1030kv 14-pole (SPM-1000)
Propeller	Propeller 10 x 5 (EFL-3246)
Servos	(4) A348 13g Sub-Micro Metal-Geared Digital Servo (SPMSA348)

*These components are not included with the Plug and Play (PNP) version of this product.

Recommended Equipment

Transmitter	NX7e+ 7 Channel Transmitter Only (SPMR7110)
Flight Battery	2200mAh 4S 14.8V Smart G2 LiPo 50C; IC3 (SPMX224S50)
Battery Charger	Smart S1200 G2 AC Charger; 1x200W (SPMXC2020)
Power Bundle	Smart Powerstage 4S Air Bundle: (2) G2 2200mAh 4S 50C LiPo IC3 & S250 Charger (SPMXPSA500)

Optional Accessories

SPM6730	Smart Charger Case
SPMR7120	NX7e+ Black Edition 14 Channel Transmitter Only
SPMX22003S100	2200mAh 3S 11.1V 100C Smart LiPo Battery; IC3
SPMX22004S30	2200mAh 4S 14.8V Smart LiPo 30C; IC3
SPMX32003S30	3200mAh 3S 11.1V Smart LiPo 30C; IC3
SPMX32004S30	3200mAh 4S 14.8V Smart LiPo Battery 30C; IC3
SPMXBC200	XBC200 Smart Battery Checker & Servo Tester
SPMXC2050	S155 55W AC G2 Smart Charger
SPMXCA300	Smart Lipo Bag, 16 x7.5 x 6.5 cm

Required Tools

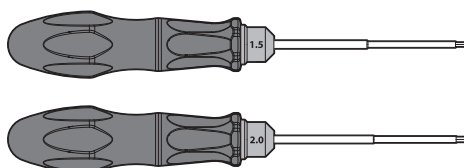

- Hex Drivers (1.5mm, and 2mm)



- 10mm or Adjustable Wrench

SAFE® Select Technology (BNF Basic)

The evolutionary SAFE® Select technology can offer an extra level of protection so you can perform the first flight with confidence. No complex transmitter programming is required. Just follow the simple bind process to make the SAFE Select system active. When activated, bank and pitch limitations keep you from over-controlling and automatic self-leveling makes recovery from risky or confusing attitudes as simple as releasing the sticks. In fact, with the aileron, elevator and rudder sticks in the neutral position, SAFE Select will automatically keep the airplane in a straight and level attitude.

Expand the advantage of what SAFE Select technology offers by assigning it to a switch. No transmitter programming is required and you'll be able to turn the system ON and OFF with the flip of a switch. Turn it OFF in flight for unrestricted aerobatic performance, and turn it back ON when a buddy wants to try out your cool aircraft. Turn SAFE Select ON for landings. It will help keep the correct pitch attitude and wings level during the final approach. Whether you're a beginner or an expert, SAFE Select can make your flights a great experience. When the normal bind process is followed, the SAFE Select system is disabled, leaving specially tuned AS3X+® technology in place to deliver a pure, unrestricted flight experience.

Smart® Transmitter Setup

The receiver installed in the aircraft contains an AS3X+/SAFE setup file developed specifically for this aircraft. This Smart Transmitter File (STF) allows you to quickly import the transmitter settings directly from the receiver during the binding process.

To load the Smart Transmitter File:

1. Turn on the transmitter.
2. Create a new blank model file on the transmitter.
3. Power on the receiver.
4. Press the bind button on the receiver.
5. Put the transmitter into bind mode: the model will bind normally.
6. Once the bind is complete, the download screen appears:
7. Select **LOAD** to continue.

The following screen is a warning that downloading overwrites all settings of the currently selected model. If this is a new blank model, the file populates the transmitter parameters into the active model and renames it Super Decathlon 1.2m.

NOTICE: Confirming will override any previously saved transmitter setups.

8. Press **CONFIRM** to continue.

The file is installed on the transmitter and the telemetry information loads automatically when the download is complete. The radio returns to the home screen, and the new model name is displayed

The transmitter setup is now complete, and the aircraft is ready to fly.

Important Notes

Flight Timer

The STF does not populate a flight timer in the transmitter. The voltage monitor provides transmitter alerts when battery voltage drops to just above the LVC, indicating it is time to land. The transmitter alert is set so there is time to land before the ESC begins to surge (pulse) when LVC is reached. This method takes flying style and throttle use into account and is more precise than a timer alone. If you are not using the STF, set a timer for 3.5 minutes when using the recommended battery. Monitor the battery usage and adjust the timer after the initial flights to best suit your flying style.

Smart Transmitter File	
The receiver contains a pre-loaded Smart Transmitter file.	
RX Version: EFL20550	1.0.0
Do you want to the load the file from the receiver	
SKIP	LOAD

NOTICE	
This WILL overwrite ALL current model settings.	
If stock BNF model hardware has changed, the receiver's file may not work properly- Do not use without checking everything.	
Do you want to the load the file from the receiver	
BACK	CONFIRM

Supported Transmitters, and firmware requirements, include the following:

- All NX Radios (with firmware version 4.0.11+)
- iX14 (with app version 2.0.9+)
- iX20 (with app version 2.0.9+)
- iX12 and DX radios do not currently support Smart Transmitter File transfers.

Manual Transmitter Setup

IMPORTANT: After you set up your model, always rebind the transmitter and receiver to set the desired failsafe positions.

For the first flight, set the flight timer to 3.5 minutes when using a 4S 2200mAh battery. Adjust the time after the initial flight.

Dual Rates

Attempt your first flights in low rate. For landings, use high rate elevator.

NOTICE: To ensure AS3X+ technology functions properly, do not lower rate values below 50%. If less control deflection is desired, manually adjust the position of the pushrods on the servo arm.

NOTICE: If oscillation occurs at high speed, refer to the Troubleshooting Guide for more information.

Exponential

After first flights, you may adjust exponential in your transmitter.

Integrated ESC Telemetry

Telemetry Settings	
Rx V : Min Rx V	4.2V
Smart ESC : Low Voltage Alarm	3.4V
Smart Battery : Startup Volt Minimum	4.0V
Motor Pole Count	14

BNF: This aircraft includes telemetry between the ESC and receiver, which can provide information including RPM, voltage, motor current, throttle setting (%), and FET (speed controller) temperature.

PNP: The ESC in this aircraft is capable of delivering telemetry information over the throttle connection when paired with a Smart compatible Spektrum telemetry receiver. It will function with a normal PWM servo signal for common radio control systems.

For more information about compatible transmitters, firmware updates, and how to use the telemetry technology on your transmitter, visit www.SpektrumRC.com.

Telemetry Setup	
DX series, NX series, iX series	1. Begin with the transmitter bound to the receiver.
	2. Power ON the transmitter.
	3. Set switch H (throttle cut) to prevent accidental motor operation.
	4. Power ON the aircraft. A signal bar appears on your transmitter's main screen when the telemetry information is being received.
	5. Go to the FUNCTION LIST (Model Setup)
	6. Select TELEMETRY; Smart ESC
	7. Set Total Cells: 4
	8. Set LVC Alarm: 3.4V Set Alarm; Voice/Vibe
	9. Set pole count; 14 pole

NX Series Transmitter Setup	
1. Power ON your transmitter, click on scroll wheel, roll to System Setup and click the scroll wheel. Select YES .	
2. Go to Model Select and choose Add New Model near the bottom of the list. Select Airplane Model Type by choosing airplane image, select Create .	
3. Set Model Name : Input a name for your model file.	
4. Go to Aircraft Type and scroll to the wing selection, choose Wing: Normal; Tail: Normal	
5. Select Main Screen , Click the scroll wheel to enter the Function List .	
6. Go to the Rates and Expo menu to set D/R and Expo .	
7. Set Rates and Expo: Aileron Set Switch: Switch F Set High Rates: 100%, Expo 10% — Low Rates: 70%, Expo 5%	
8. Set Rates and Expo: Elevator Set Switch: Switch C Set High Rates: 100%, Expo 10% — Low Rates 70%, Expo 5%	
9. Set Rates and Expo: Rudder Set Switch: Switch G Set High Rates: 100%, Expo 10% — Low Rates 70%, Expo 5%	
10. Set Throttle Cut; Switch: Switch H, Position: -100%	

DX Series Transmitter Setup	
1. Power ON your transmitter, click on scroll wheel, roll to System Setup and click the scroll wheel. Select YES .	
2. Go to Model Select and choose Add New Model at the bottom of the list. The system asks if you want to create a new model, select Create .	
3. Set Model Type : Select Airplane Model Type by choosing the airplane. The system asks you to confirm model type, data will be reset. Select YES .	
4. Set Model Name : Input a name for your model file.	
5. Go to Aircraft Type and scroll to the wing selection, choose Wing: Normal; Tail: Normal	
6. Select Main Screen , Click the scroll wheel to enter the Function List .	
7. Set D/R (Dual Rate) and Expo: Aileron Set Switch: Switch F Set High Rates: 100%, Expo 10% — Low Rates: 70%, Expo 5%	
8. Set D/R (Dual Rate) and Expo: Elevator Set Switch: Switch C Set High Rates: 100%, Expo 10% — Low Rates 70%, Expo 5%	
9. Set D/R (Dual Rate) and Expo: Rudder Set Switch: Switch G Set High Rates: 100%, Expo 10% — Low Rates 70%, Expo 5%	
10. Set Throttle Cut; Switch: Switch H, Position: -100%	

iX Series Transmitter Setup	
1. Power ON your transmitter and begin once the Spektrum AirWare app is open. Select the orange pen icon in the screen's upper left corner, the system asks for permission to Turn Off RF , select PROCEED .	
2. Select the three dots in the upper right corner of the screen, select Add a New Model .	
3. Select Model Option , choose DEFAULT , select Airplane . The system asks if you want to create a new acro model, select Create .	
4. Select the last model on the list, named Acro . Tap on the word Acro and rename the file to a name of your choice.	
5. Press and hold the back arrow icon in the upper left corner of the screen to return to the main screen.	
6. Go to the Model Setup menu. Select Aircraft Type . The system asks for permission to Turn Off RF , select PROCEED . Touch the screen to select Wing/Tail Type . Select Wing: Normal; Tail: Normal .	
7. Press and hold the back arrow icon in the upper left corner of the screen to return to the main screen.	
8. Go to the Model Adjust menu.	
9. Set Dual Rates and Expo: Select Aileron Set Switch: Switch F Set High Rates: 100%, Expo 10% — Low Rates: 70%, Expo 5%	
10. Set Dual Rates and Expo: Select Elevator Set Switch: Switch C Set High Rates: 100%, Expo 10% — Low Rates 70%, Expo 5%	
11. Set D/R (Dual Rate) and Expo: Rudder Set Switch: Switch G Set High Rates: 100%, Expo 10% — Low Rates 70%, Expo 5%	
12. Set Throttle Cut; Switch: Switch H, Position: -100%	

Model Assembly

Landing Gear Installation

1. Install the landing gear (A) in the bottom of fuselage.
2. Install the landing gear mounting plate (B) over the landing gear.
3. Secure with six, M3 x 10mm screws (C) using 2mm hex driver. Be careful not to overtighten the screws.

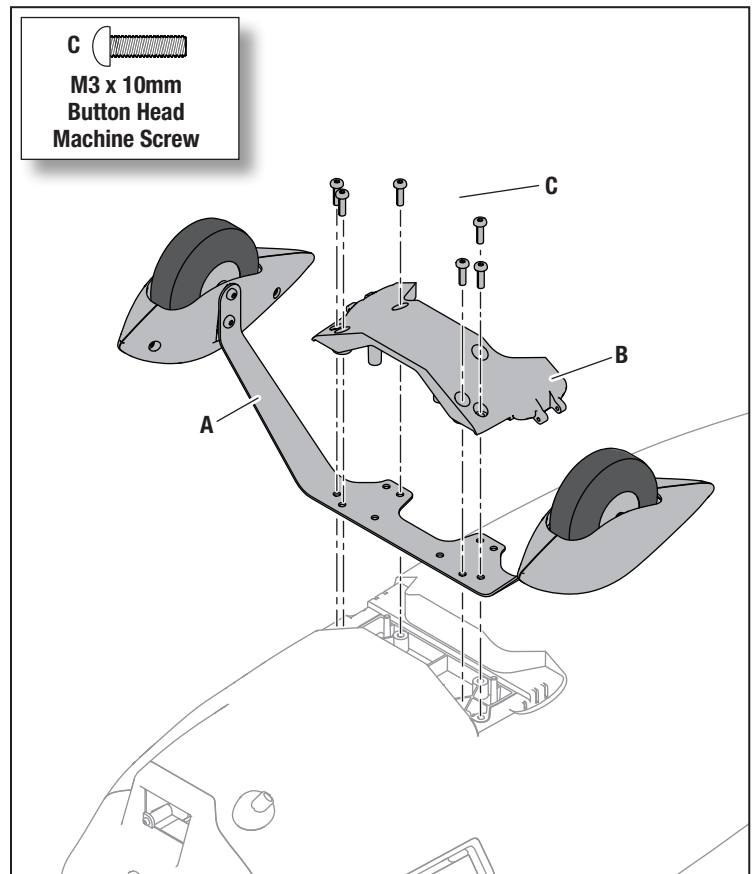

Tail Installation

1. Insert the two tabs of the vertical stabilizer (A) through the holes in the horizontal stabilizer (B) and into the holes of the fuselage.

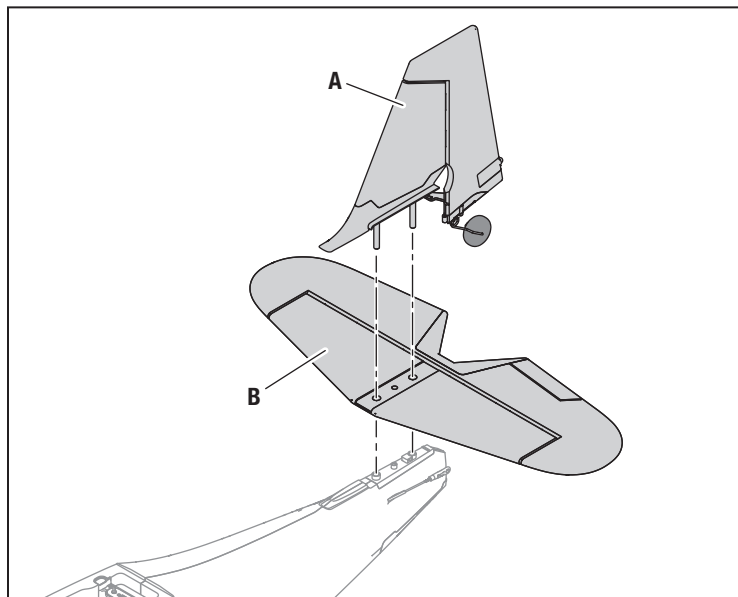

2. Using a 1.5mm hex driver, secure the tail assembly with two 2.5mm x 15mm self-tapping screws (C) inserted from the bottom of the fuselage and one 2mm x 8mm self-tapping screw (D) into the tail wheel bracket as shown.

IMPORTANT: DO NOT overtighten the screws. If tailwheel screw is overtightened it will bind the rudder. Snug the screw tight, then loosen 1/4 turn. Move the rudder left and right to check for free movement, then connect the rudder linkage.

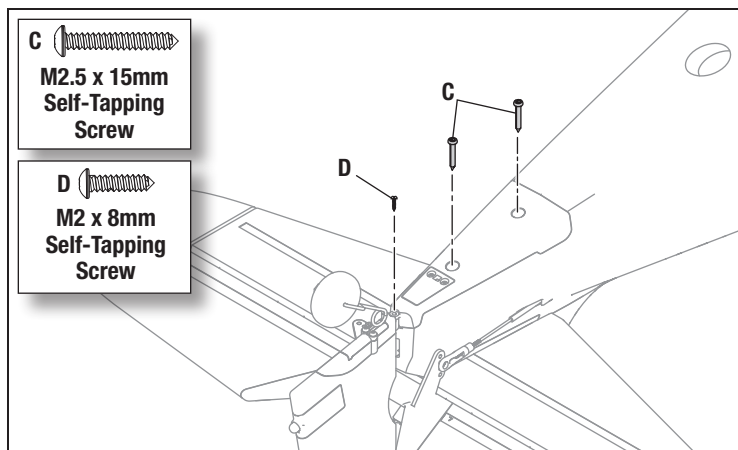

3. Snap the ball link on the elevator control horn to the elevator pushrod (E).
4. Deflect the rudder to access and connect the rudder LED plug (F) to the port at the rear of the fuselage, as shown. The LED plug will have a label indicating the inside of the plug. Ensure the inside faces the rudder for correct polarity.

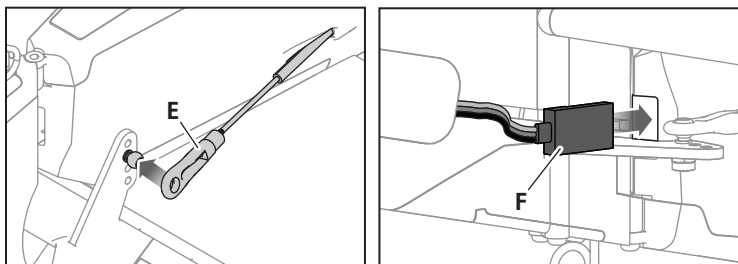

5. Snap the ball link on the rudder control horn to the rudder pushrod (G).

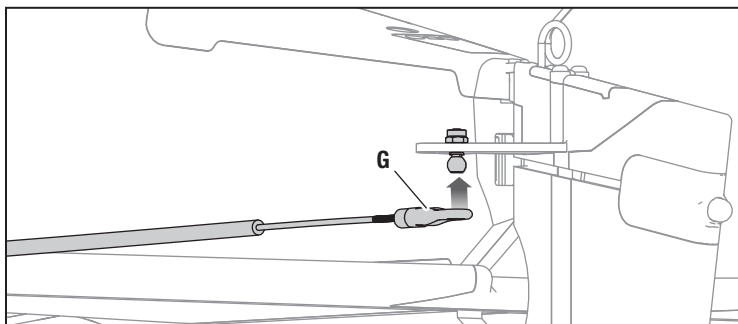

Wing Installation

1. With the wing inverted, remove the wing strut ends from the strut transport clip (A). Lift the end of the clip of the strut transport clip to remove from the wing.

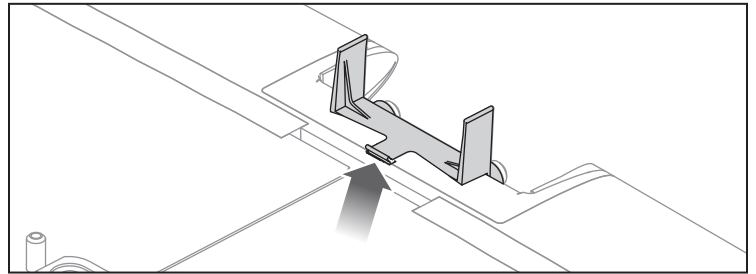
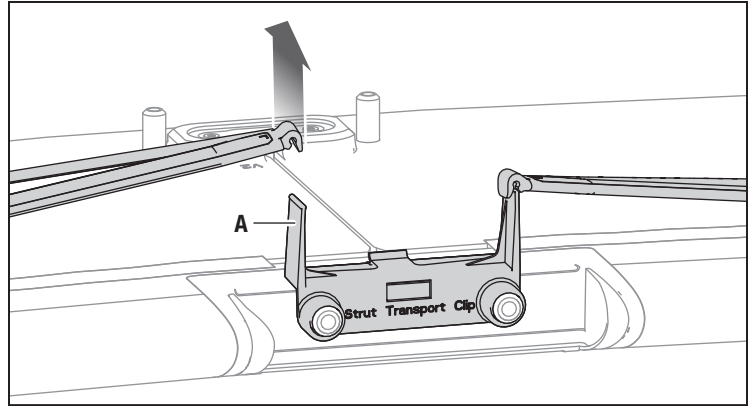

2. Remove the battery hatch from the fuselage.
3. Secure the wing clip in the storage mount area (B) in the fuselage. Use the support clip again when flying is finished and the aircraft is transported.

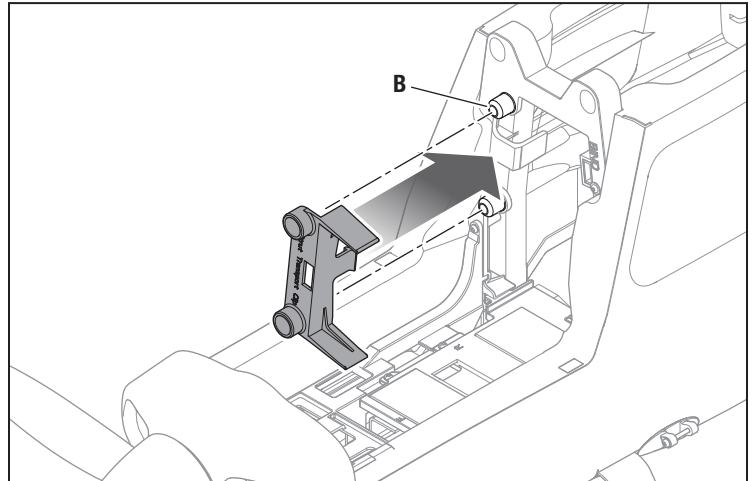

4. Install the wing on the fuselage allowing the wing struts to hang below the fuselage.
5. Install the wing by inserting the front wing mount tabs into the upper holes in the fuselage former.

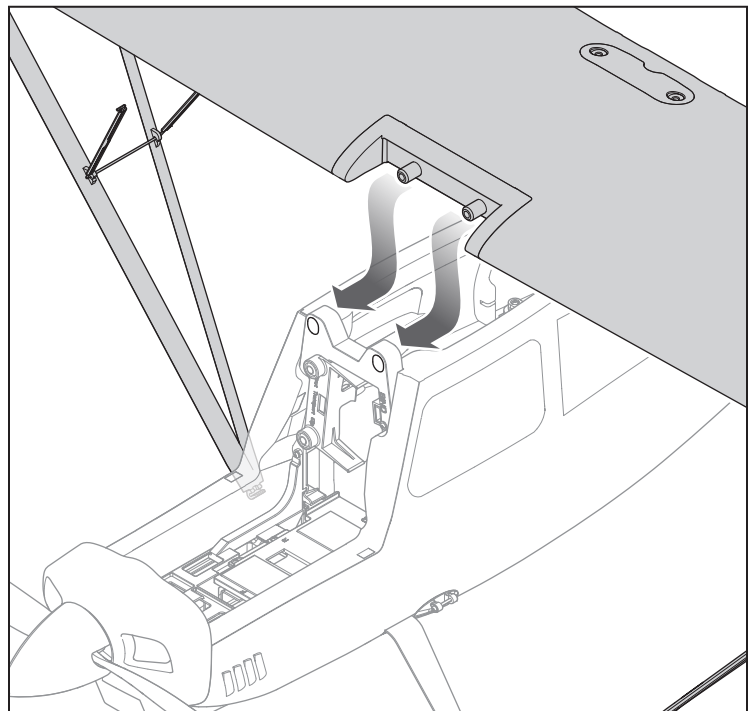

6. Ensure the hands free servo connection engages correctly.

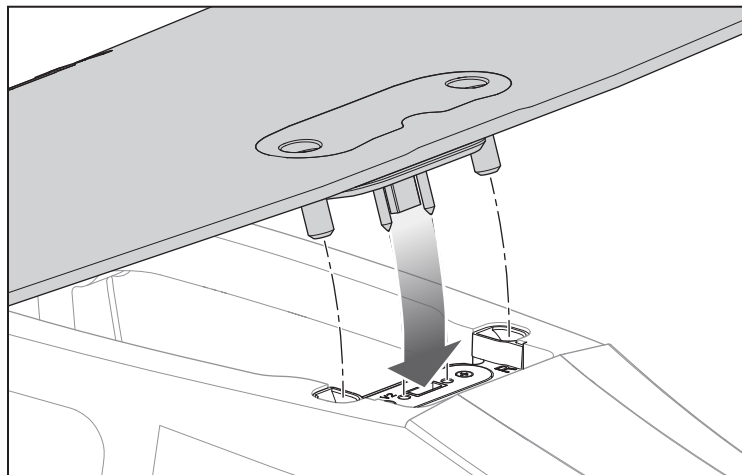

7. Press down gently on the rear of the wing to ensure the hands-free servo connectors are fully seated.

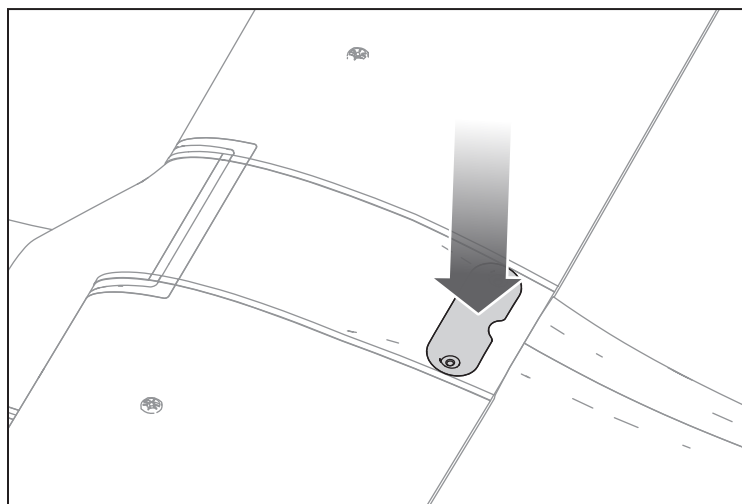

8. Secure the wing in place using the two M3 x 25mm (A) thumb machine screws.
IMPORTANT: DO NOT overtighten the thumb screws.

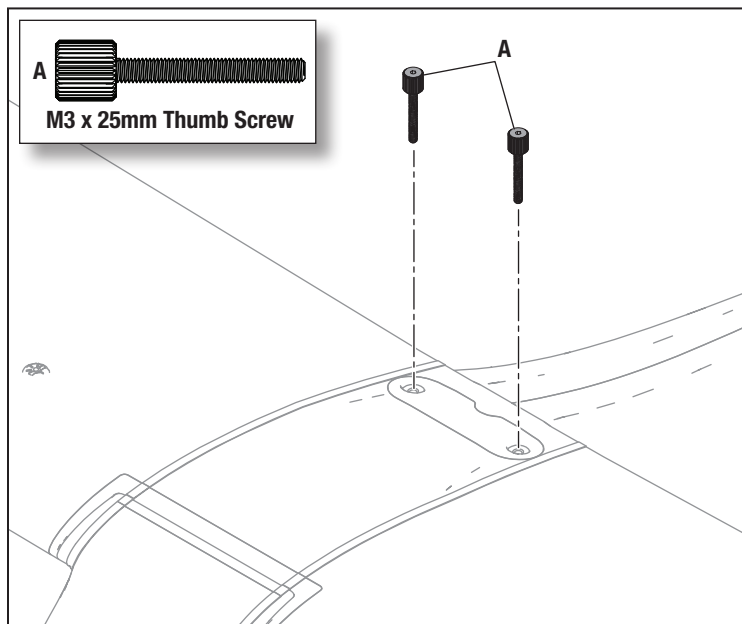

9. Swing the jury strut into position **(B)** and gently squeeze together to insert the pins into the slots in the underside of the wing.

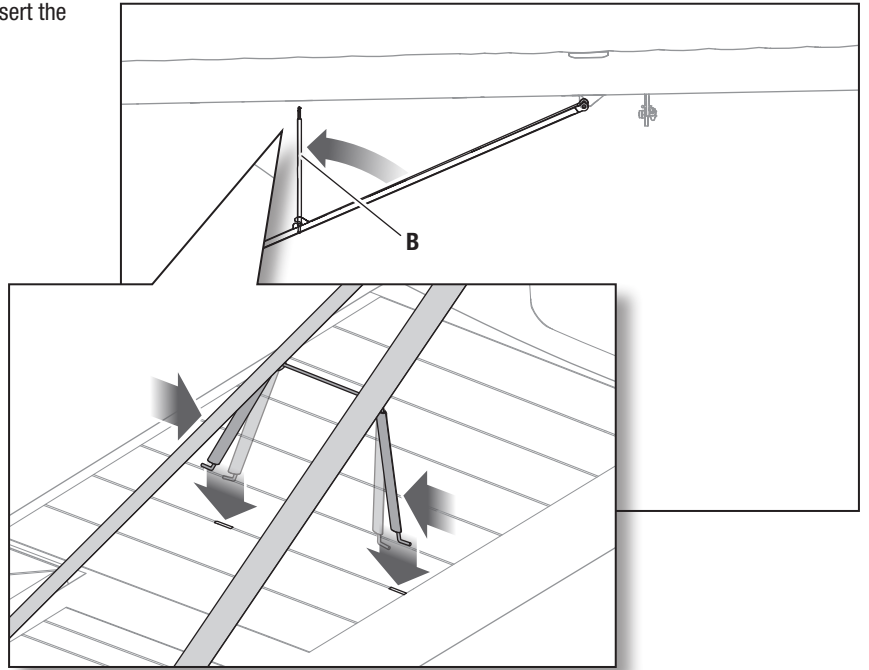

10. Snap the struts **(C)** onto the horizontal pin **(D)** in the mount located at the bottom side of the fuselage.
Disassemble in reverse order.

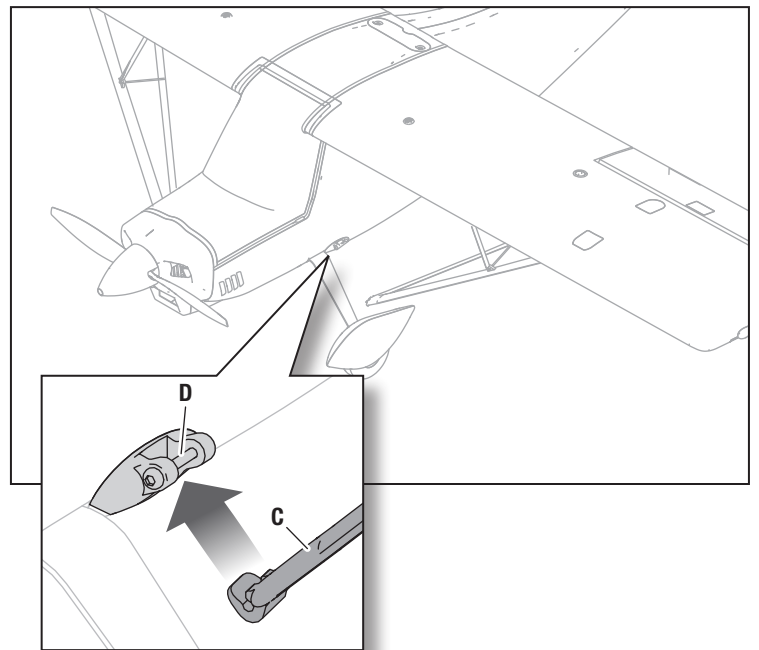

PNP Receiver Selection and Installation

The recommended receiver for this aircraft is the Spektrum AR631+. If you choose to install a different receiver, ensure that it is at least a 6-channel full range receiver. Refer to the manual of your chosen receiver for correct installation and operation instructions.

AR631+ Installation

1. Remove the wing to access the receiver compartment.
2. Connect the control surface servos to their respective ports on the receiver using the table at the right.
3. Using double-sided servo tape (not included) mount the receiver to the flat area of the receiver compartment, in the orientation shown, parallel to the length of the fuselage, with the label facing up and the servo ports towards the rear of the aircraft.

IMPORTANT: The orientation of the receiver is critical for all AS3X+® and SAFE® technology setups.

4. For single antenna receivers, route the antenna through the tube on the right side of the fuselage (A). For dual antenna receivers route the left antenna to the front of the fuselage, and insert the right antenna to the right side tube.



CAUTION: Incorrect installation of the receiver could cause a crash.

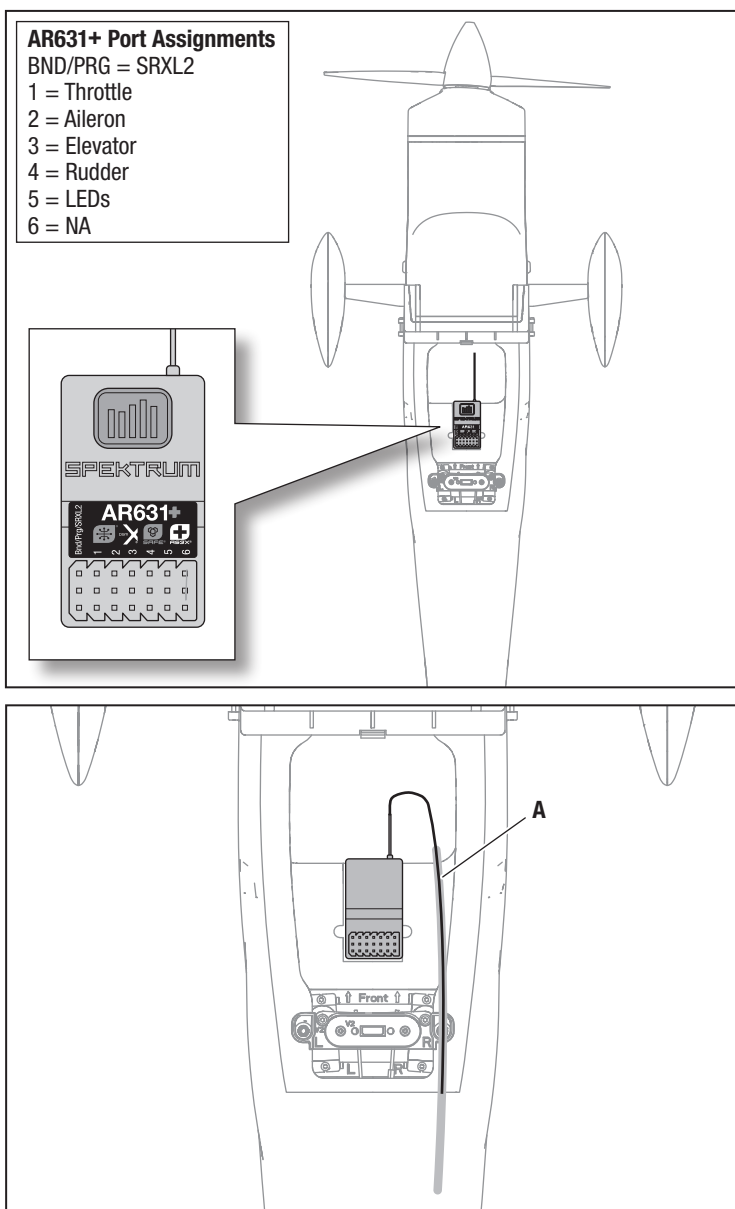

Battery Installation and ESC Arming

Battery Selection

We recommend the Spektrum 2200mAh 4S 14.8V Smart G2 50C Li-Po battery (SPMX224S50). Refer to the Optional Parts List for other suitable batteries. If using a battery other than those listed, the battery should be within the range of capacity, dimensions and weight of the Spektrum Li-Po battery packs to fit in the fuselage. Be sure the model balances at the recommended CG.

CAUTION: Always keep hands away from the propeller. When armed, the motor will turn the propeller in response to any throttle movement.

1. Lower the throttle and throttle trim to the lowest settings. Power on the transmitter, then wait 5 seconds.
2. Apply the soft loop portion of adhesive hook and loop tape (A) to the bottom of your battery.
3. Pull up on the two side tabs located along the seam on each side of the battery hatch (B) to remove.

4. Install the fully charged battery (C) in the battery compartment as shown. See the **Adjusting the Center of Gravity** instructions for more information.

5. Secure the flight battery with the hook and loop straps (D).
6. Connect the battery to the ESC.
7. Keep the aircraft level on its wheels, immobile and away from wind or the system will not initialize.

Once armed:

 - The ESC will sound a series of tones (number of tones depend on the cell count of the battery).
 - The control surfaces will cycle once for AS3X+, or twice for SAFE technology if it is turned ON.
 - An LED will light on the receiver.
8. Reinstall the battery hatch.

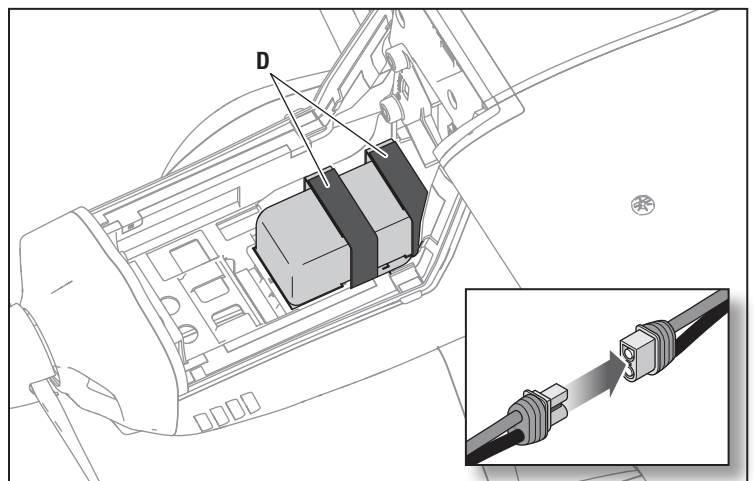
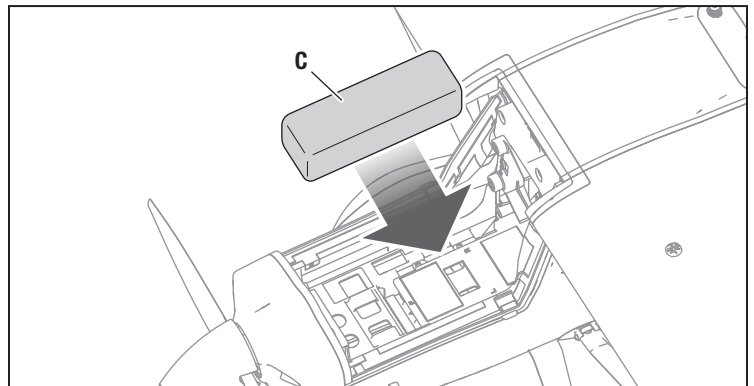
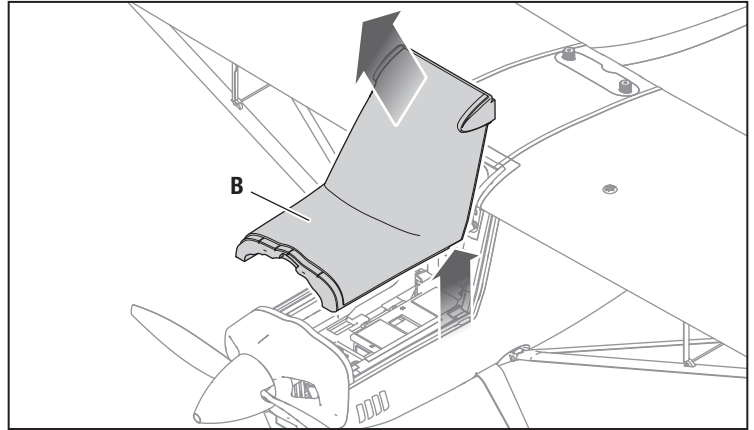
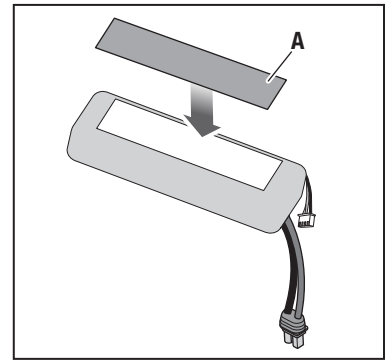
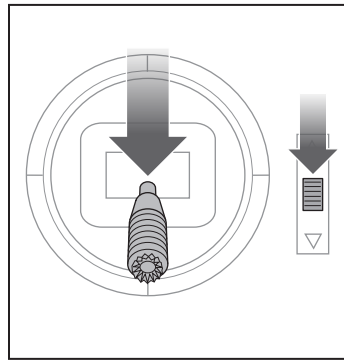

Center of Gravity (CG)

The CG location is measured from the leading edge where the wing meets the fuselage. This CG location has been determined with the recommended 2200mAh 4S 14.8V Smart G2 50C LiPo battery (SPMX224S50). Check the CG with the model upright. Adjust the battery forward or aft as needed to achieve the proper CG location.

CAUTION: Install the battery but do not arm the ESC while checking the center of gravity. Personal injury may result.

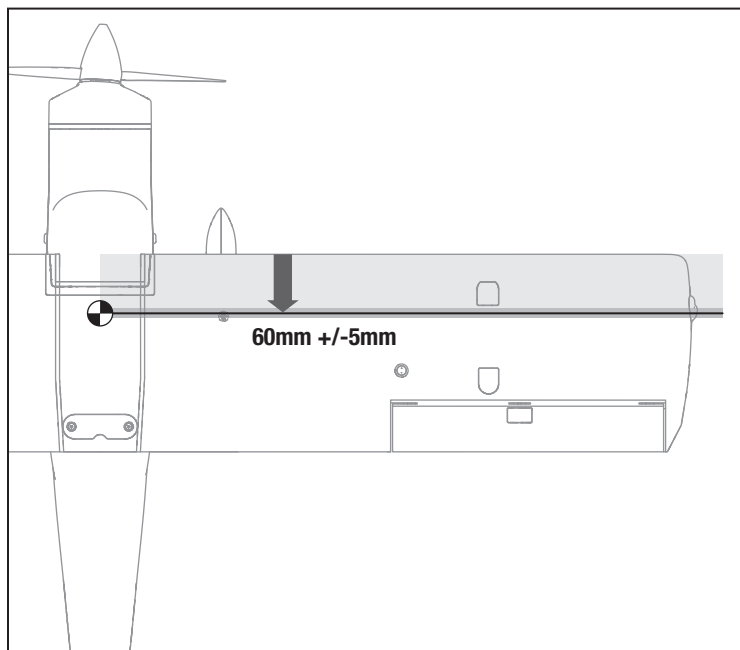

Remote Bind Port (BNF Basic)

To help facilitate the binding process, the BNF Basic version of the aircraft has a remote bind port installed in the rear of the battery compartment. Follow the Transmitter and Receiver Binding instructions, using the remote bind port, rather than removing the wing to access the receiver bind button or port.

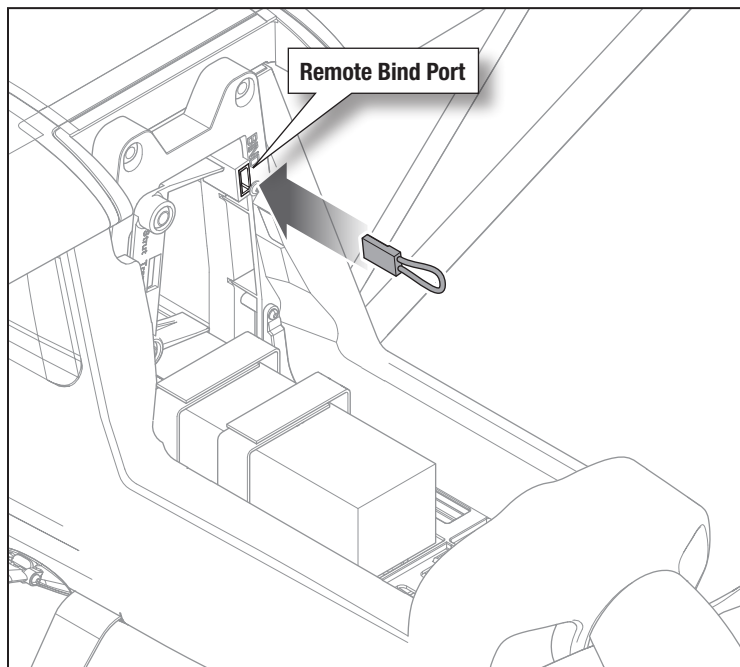

General Binding Tips and Failsafe

- The included receiver has been specifically programmed for operation of this aircraft. Refer to the receiver manual for correct setup if the receiver is replaced.
- Keep away from large metal objects while binding.
- Do not point the transmitter's antenna directly at the receiver while binding.
- The red LED on the receiver will flash rapidly when the receiver enters bind mode.
- Once bound, the receiver will retain its bind settings for that transmitter until you re-bind.
- If the receiver loses transmitter communication, the failsafe will activate. Failsafe moves the throttle channel to low throttle. Pitch and roll channels move to actively stabilize the aircraft in a descending turn.
- If problems occur, refer to the troubleshooting guide or if needed, contact the appropriate Horizon Product Support office.

Transmitter and Receiver Binding / Enable or Disable SAFE Select

The BNF Basic version of this airplane includes SAFE Select technology, enabling you to choose the level of flight protection. SAFE mode includes angle limits and automatic self leveling. AS3X+ mode provides the pilot with a direct response to the control sticks. SAFE Select is enabled or disabled during the bind process. With SAFE Select disabled the aircraft is always in AS3X+ mode. With SAFE Select enabled the aircraft will be in SAFE Select mode all the time, or you can assign a switch to toggle between SAFE Select and AS3X+ modes.

Thanks to SAFE Select technology, this aircraft can be configured for full-time SAFE mode, full-time AS3X+ mode, or mode selection can be assigned to a switch.

IMPORTANT: Before binding, read the transmitter setup section in this manual and complete the transmitter setup table to ensure your transmitter is properly programmed for this aircraft.

IMPORTANT: Move the transmitter flight controls (rudder, elevators, and ailerons) and the throttle trim to neutral. Move the throttle to low before and during binding. This process defines the failsafe settings.

You can use either the **bind button** on the receiver case **OR** a conventional **bind plug** to complete the binding and SAFE Select process.

SAFE can also be enabled via Forward Programming.

Using The Bind Button...

To Enable SAFE Select

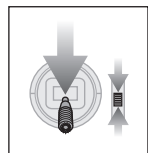

Lower Throttle

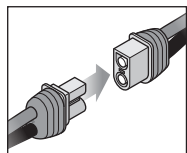

Connect Power

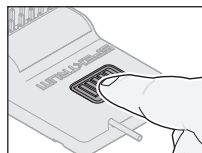

Press and Hold Bind Button

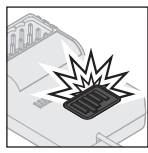

Orange Flashing LED

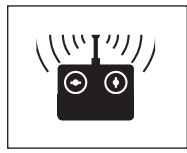

Bind TX to RX

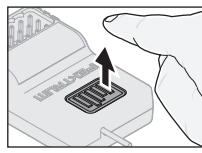

Release Bind Button

SAFE SELECT ENABLED: The control surfaces cycle back and forth **twice** with a slight pause at neutral position every time the receiver is powered on.

To Disable SAFE Select

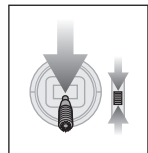

Lower Throttle

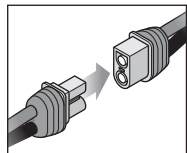

Connect Power

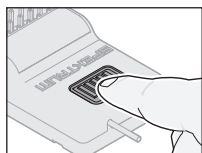

Press and Hold Bind Button

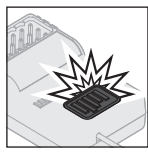

Orange Flashing LED

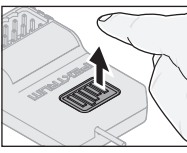

Release Bind Button

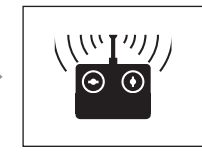

Bind TX to RX

SAFE SELECT DISABLED: The control surfaces cycle back and forth **once** every time the receiver is powered on.

Using The Bind Plug...

To Enable SAFE Select

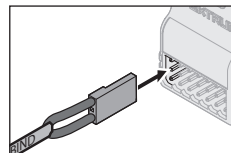

Install Bind Plug

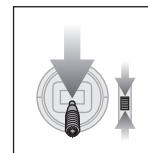

Lower Throttle

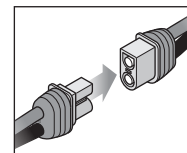

Connect Power

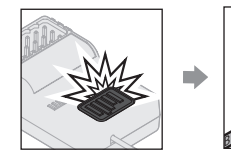

Orange Flashing LED

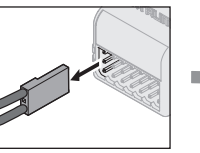

Remove Bind Plug

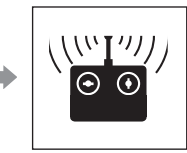

Bind TX to RX

SAFE SELECT ENABLED: The control surfaces cycle back and forth **twice** with a slight pause at neutral position every time the receiver is powered on.

To Disable SAFE Select

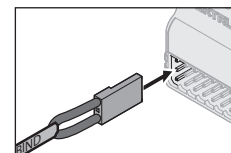

Install Bind Plug

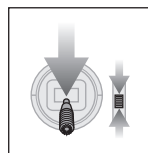

Lower Throttle

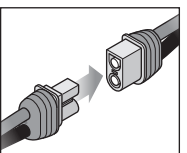

Connect Power

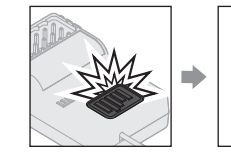

Orange Flashing LED

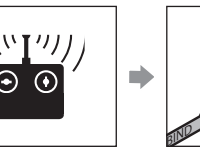

Bind TX to RX

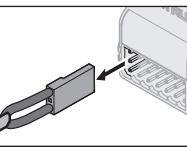

Remove Bind Plug

SAFE SELECT DISABLED: The control surfaces cycle back and forth **once** every time the receiver is powered on.

SAFE® Select Switch Designation (BNF)

Stick Inputs

Once SAFE Select is enabled, you can choose to fly in SAFE mode full-time, or assign a switch. Any switch on any channel between 5 and 20 can be used on your transmitter.

If the aircraft is bound with SAFE Select disabled, the aircraft will be in AS3X+ mode exclusively.

CAUTION: Keep all body parts well clear of the propeller and keep the aircraft securely restrained in case of accidental throttle activation.

IMPORTANT: To be able to assign a switch, first verify:

- The aircraft was bound with SAFE Select enabled.
- Your choice for the SAFE Select switch is assigned to a channel between 5 and 20 (Gear, Aux1-15), and travel is set at 100% in each direction.
- The aileron, elevator, rudder and throttle direction are set to normal, not reverse.
- The aileron, elevator, rudder and throttle are set to 100% travel. If dual rates are in use, the switches need to be in the 100% position.

See your transmitter manual for more information about assigning a switch to a channel.

TIP: If a SAFE Select switch is desired for your 6-function aircraft, and you are using a 6 channel transmitter, the SAFE Select switch channel will have to be shared with either channel 5 or 6 of the transmitter.

Assigning a Switch

1. Power on the transmitter.
2. Power on the aircraft.
3. Hold both transmitter sticks to the inside bottom corners, and toggle the desired switch 5 times quickly (1 toggle = full up and down).
4. The control surfaces of the aircraft will move, indicating the switch has been selected.

Repeat the process to assign a different switch or to deactivate the current switch.

SAFE Select Switch Assignment Stick Positions

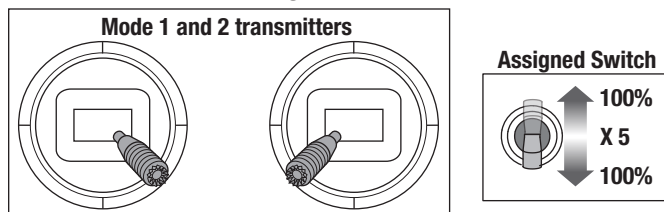

TIP: Use the channel monitor to verify channel movement.

This example of the channel monitor shows the stick positions for assigning a switch, the switch selection on Aux2, and +/- 100% travel on the switch.

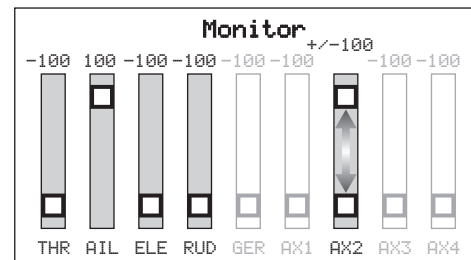

Forward Programming

Assign the SAFE Select channel through forward programming on your compatible Spektrum transmitter.



For more information about setting SAFE Select and using Forward Programming, please refer to the following link for a detailed video:

<https://www.youtube.com/watch?v=o-46P066cik>

Forward Programming SAFE Select Setup (DX, NX, and iX series)

1. Begin with the transmitter bound to the receiver.
2. Power ON the transmitter.
3. Assign a switch for SAFE Select that is not already in use for another function. Use any open channel between 5 and 20 (Gear, Aux1-15).
4. Set switch H (throttle cut) to prevent accidental motor operation.
5. Power ON the aircraft. A signal bar appears on your transmitter's main screen when the telemetry information is being received.
6. Go to the FUNCTION LIST (Model Setup)
7. Select Forward Programming; Select Gyro Settings, Choose SAFE Select to enter the menu.
8. Set SAFE Select Ch: To the channel you have chosen for SAFE Select.
9. Set AS3X+ and SAFE On or Off as desired for each switch position.

Control Direction Test

WARNING: Do not perform this or any other equipment test without turning on throttle cut. Serious injury or property damage could result from the motor starting inadvertently.

Switch on the transmitter and connect the battery. Use the transmitter to operate the aileron, elevator and rudder controls. View the aircraft from the rear when checking the control directions.

Elevator



1. Pull the elevator stick back. The elevators should move up, which will cause the aircraft to pitch up.
2. Push the elevator stick forward. The elevators should move down, which will cause the aircraft to pitch down.

Ailerons

1. Move the aileron stick to the right. The right aileron should move up and the left aileron down, which will cause the aircraft to bank right.
2. Move the aileron stick to the left. The left aileron should move up and the right aileron down, which will cause the aircraft to bank left.

Rudder

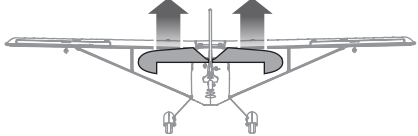
1. Move the rudder stick to the right. The rudder should move to the right, which will cause the aircraft to yaw right.
2. Move the rudder stick to the left. The rudder should move to the left, which will cause the aircraft to yaw left.

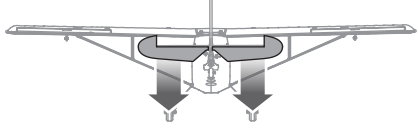
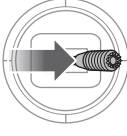
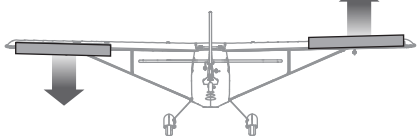
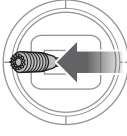
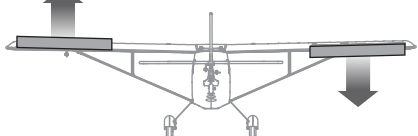
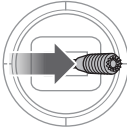
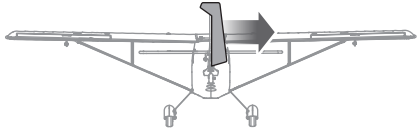
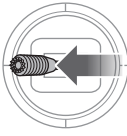
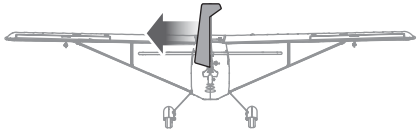
	Transmitter Command	Control Surface Response
Elevator		
		
Aileron		
		
Rudder		
		

AS3X+ Response Test

WARNING: Do not perform this or any other equipment test without turning on throttle cut. Serious injury or property damage could result from the motor starting inadvertently.

This test ensures that the AS3X+® control system is functioning properly. Assemble the aircraft and bind your transmitter to the receiver before performing this test.

1. Raise the throttle just above 25%, then lower the throttle to activate AS3X+.

CAUTION: Keep all body parts, hair and loose clothing away from a moving propeller, as these items could become entangled.

2. Move the entire aircraft as shown and ensure the control surfaces move in the direction indicated in the graphic. If the control surfaces do not respond as shown, do not fly the aircraft. Refer to the receiver manual for more information.

Once the AS3X+ system is active, control surfaces may move rapidly. This is normal. AS3X+ remains active until the battery is disconnected.

Due to different effects of torque, lift, and drag some aircraft require trim changes with different speeds and throttle settings. Mixes are preloaded into the receiver to compensate for these changes. The mixes become active the first time the throttle is raised above 25%. The control surfaces may be offset slightly at different throttle settings after the first time throttle is raised. Trimming the plane in flight should be done at 80-100% throttle for best results.

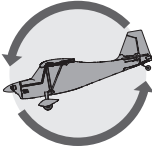
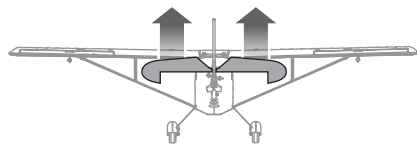
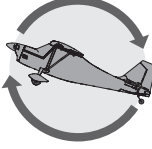
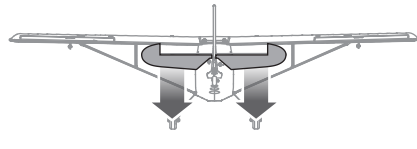
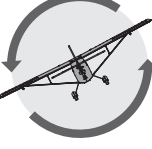
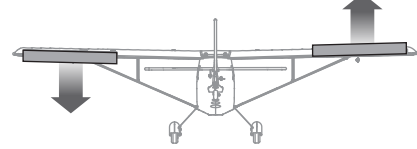
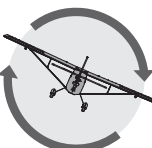
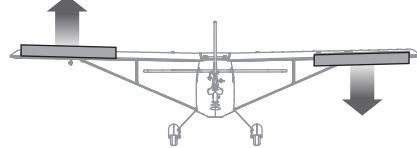
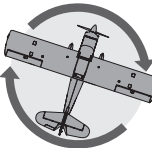
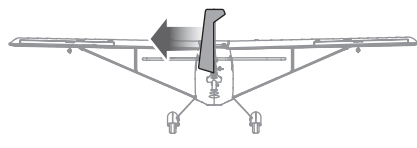
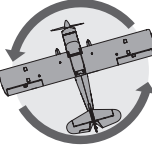
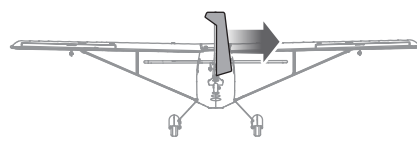
	Aircraft movement	AS3X+ Reaction
Elevator		
		
Aileron		
		
Rudder		
		

Control Surface Centering and Adjusting a Ball Link

IMPORTANT: Perform the Control Direction Test before performing control surface centering.

While SAFE is inactive, mechanically center the control surfaces.

IMPORTANT: Correct operation of the SAFE system requires sub-trim and trim at 0.

After binding a transmitter to the receiver, set the trims and sub-trims to 0, ensure the servo arms are in the correct positions, then adjust the linkages to center the control surfaces.

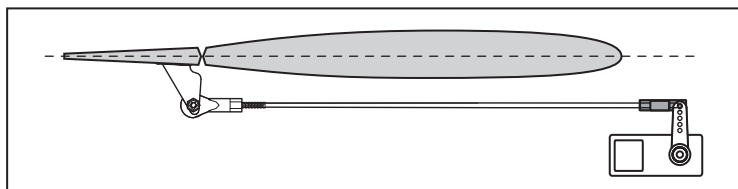

- Turn the linkage clockwise or counterclockwise until the control surface is centered.
- Attach the linkage to the servo arm or control horn after adjustment.

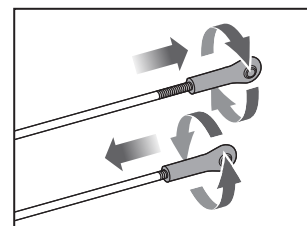

Control Horn and Servo Arm Factory Settings

The table to the right shows the factory settings for the control horns and servo arms. Fly the aircraft at factory settings before making changes. After flying, you may choose to adjust the linkage positions for the desired control response. See the table to the right.

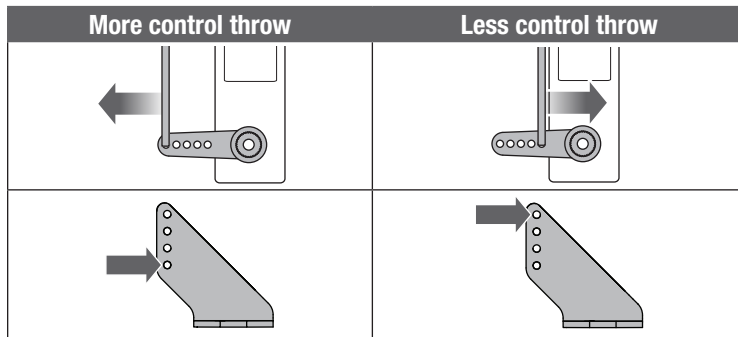

	Control Horns	Servo Arms
Elevator		
Ailerons		
Rudder		

Dual Rates and Control Throws

Program your transmitter to set the rates and control throws to the values given. These values have been tested and are a good starting point to achieve successful flight. After flying, you may choose to adjust the values for the desired control response.

	High Rate	Low Rate
Aileron	▲ = 24mm ▼ = 14mm	▲ = 14mm ▼ = 11mm
Elevator	▲ = 24mm ▼ = 24mm	▲ = 18mm ▼ = 18mm
Rudder	▶ = 35mm ◀ = 35mm	▶ = 20mm ◀ = 20mm

SAFE Select Flying Tips (BNF)

When flying in SAFE Select mode the aircraft will return to level flight any time the aileron and elevator controls are at neutral. Applying aileron or elevator control will cause the airplane to bank, climb or dive. The amount the stick is moved will determine the attitude the airplane flies. Holding full control will push the aircraft to the pre-determined bank and roll limits, but it will not go past those angles.

When flying with SAFE Select, it is normal to hold the control stick deflected with moderate aileron input when flying through a turn. To fly smoothly with SAFE Select, avoid making frequent control changes and don't attempt to correct for minor deviations. Holding deliberate control inputs will command the aircraft to fly at a specific angle, and the model will make all corrections to maintain that flight attitude.

When flying with SAFE Select, throttle will make the aircraft climb or descend. Full throttle will cause the aircraft to pitch up and climb slightly. Mid throttle will keep the airplane flying level. Low throttle will cause the airplane to descend slightly nose-down.

Return the elevator and aileron controls to neutral before switching from SAFE Select mode to AS3X+ mode. If you do not neutralize controls when switching into AS3X+ mode, the control inputs used for SAFE Select mode will be excessive for AS3X+ mode and the aircraft will react immediately.

Differences between SAFE Select and AS3X+ modes

This section is generally accurate but does not take into account flight speed, battery charge status, and other limiting factors.

		SAFE Select	AS3X+
Control Input	Control stick is neutralized	Aircraft will self level	Aircraft will continue to fly at its present attitude
	Holding a small amount of control	Aircraft will bank or pitch to a moderate angle and maintain the attitude	Aircraft will continue to pitch or roll slowly
	Holding full control	Aircraft will bank or pitch to the predetermined limits and maintain the attitude	Aircraft will continue to roll or pitch rapidly
	Throttle	Full throttle: Climb Neutral: Level flight Low throttle: Descend	Throttle will not affect flight response.

In-Flight Trimming

During your first flight, trim the aircraft for level flight at 80-100% throttle. Make small trim adjustments with your transmitter's trim switches to achieve straight and level flight.

After adjusting trim do not touch the control sticks for 3 seconds. This allows the receiver to learn the correct settings to optimize AS3X+ performance. Failure to do so could affect flight performance.

3 seconds

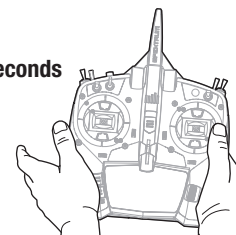

Post Flight

1. Disconnect the flight battery from the ESC.
2. Power OFF the transmitter.
3. Remove the flight battery from the aircraft.

4. Recharge the flight battery.
5. Repair or replace all damaged parts.
6. Store the flight battery apart from the aircraft and monitor the battery charge.

Thrust Reversing (Optional)

The Avian™ Smart ESC in this aircraft is equipped with thrust reversing, but it must be enabled before it will function. Reversing the motor can be helpful when taxiing or for shortening ground roll after a landing. Flipping the designated switch reverses motor rotation, throttle will still control motor speed.

 **WARNING:** Never attempt to use thrust reversing in flight. Applying reverse thrust while in flight will result in loss of control and possibly a crash. Crash damage is not covered under warranty.

IMPORTANT: The motor will draw more current in reverse as the propeller becomes less efficient and creates more drag. This can reduce flight time.

IMPORTANT: Thrust reversing requires a Spektrum receiver with Smart Throttle (including the AR637TA and AR631) and a Spektrum transmitter with a minimum of 7 channels. The Avian ESC is also backwards compatible with conventional receivers (PWM output signal) for normal operation, but reversing functions are only available with Smart Throttle technology.

Thrust Reversing Setup Transmitter

On the transmitter, select an open channel (not already in use), and assign it to an open switch. Use a different channel for thrust reversing and SAFE Select. Motor reversing is assigned to Aux 2/Channel 7, by default, in the Smart ESC. If SAFE Select and the ESC are assigned to the same channel, the motor will reverse in flight.

 **WARNING:** Do not assign thrust reversing and SAFE Select to the same channel. Doing so will reverse the motor when SAFE Select is enabled during flight, resulting in a crash.

ESC

Program the ESC for thrust reversing with the Smart ESC Programming Box (SPMXCA200, optional, not included).

Enabling the Motor / Thrust Reversing

1. Connect a 3+” servo extension to one of the short programming leads/ connectors.
2. Connect the other end of the extension to the Spektrum Smart ESC Programmer (SPMXCA200) using the port marked “ESC”. Match the polarity as marked.
 - IMPORTANT:** Orange corresponds to gray on the ESC.
3. Remove the battery hatch from the fuselage.
4. Connect a flight battery to the IC3 connector to power the ESC.
5. On the programmer press the “EDIT” button.
6. Once you see the “Brake Type” Repeatedly press the “Edit” button until “Reverse” is selected.
7. Press “Select” to change the “Brake Force”.
8. Continue pressing the “Edit” button until “7” is shown and press “Select”.
9. The default channel is Channel 7, if you would like this on a different channel repeatedly press the “Select” button until “Thrust Rev” is shown. Repeatedly press the “Edit” button until the desired channel appears.
10. Press the “Save” button on the programmer to lock in the changes.
11. Once complete, disconnect the extension from the programming lead and connect it to the other programming lead. Repeat steps 4-11.
12. Repeat steps 3-8.
13. The motor/thrust reverse feature is now enabled on the ESC.

Motor Service

CAUTION: Always disconnect the flight battery before performing motor service.

Disassembly

1. Remove the spinner screw (M2.5 x 8mm hex machine screw) (A), spinner (B), propeller nut (M6) (C), propeller (D), washer (E).
2. Remove 4 screws (M2 x 8mm hex self-tapping screws) (F) and remove the motor cowling (G).
- IMPORTANT:** The front LED is connected to the cowling. Carefully let the cowling hang from the fuselage or disconnect the LED plug from the receiver and remove the LED wire from the fuselage.
3. Remove 3 screws (M2.5 x 7mm machine screws) (H) and remove the prop adapter (I) from the motor (J).
4. Remove the 4 screws (M3 x 12mm hex self-tapping screws) (K) from the motor mount (L).
5. Remove the motor and motor mount from the fuselage.
6. Disconnect the motor wires from the ESC wires.
7. Remove the 4 screws (M3 x 6mm philips machine screws) (M), and motor from the motor mount.

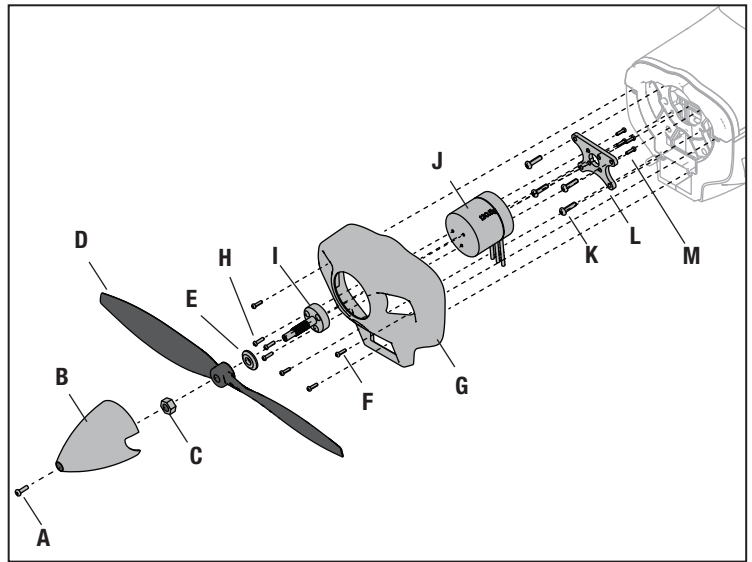

Assembly

Assemble in reverse order.

- Correctly align and connect the motor wire colors with the ESC wires.
- Install the propeller as shown.
- Tighten the spinner nut by using wrench.
- Tighten the spinner screw by using a hex driver.

Servo Service

Control Surface	Replacement Servo	Description	Replacement Adhesive
Aileron	SPMSA348	A348 13g Sub-Micro Metal-Geared Digital Servo	Deluxe Materials Foam 2 Foam (DLMAD34)
Elevator			
Rudder			

Troubleshooting Guide AS3X+

Problem	Possible Cause	Solution
Oscillation	Damaged propeller or spinner	Replace propeller or spinner
	Imbalanced propeller	Balance the propeller.
	Motor vibration	Replace parts or correctly align all parts and tighten fasteners as needed
	Loose receiver	Align and secure receiver in fuselage
	Loose aircraft controls	Tighten or otherwise secure parts (servo, arm, clevis, horn and control surface)
	Worn parts	Replace worn parts (especially propeller, spinner or servo)
	Irregular servo movement	Replace servo
Inconsistent flight performance	Trim is not at neutral	If you adjust trim more than 8 clicks, adjust the clevis to remove trim
	Sub-Trim is not at neutral	No Sub-Trim is allowed. Adjust the servo linkage
	Aircraft was not kept immobile for 5 seconds after battery connection	With the throttle stick in lowest position. Disconnect battery, then reconnect battery and keep the aircraft still for 5 seconds
Incorrect response to the AS3X+ Control Direction Test	Incorrect direction settings in the receiver, which can cause a crash	DO NOT fly. Contact Product Support for a solution.

Troubleshooting Guide

Problem	Possible Cause	Solution
Aircraft will not respond to throttle but responds to other controls	Throttle not at idle and/or throttle trim too high	Reset controls with throttle stick and throttle trim at lowest setting
	Throttle servo travel is lower than 100%	Make sure throttle servo travel is 100% or greater
	Throttle channel is reversed	Reverse throttle channel on transmitter
	Motor disconnected from ESC	Make sure motor is connected to the ESC
Extra propeller noise or extra vibration	Damaged propeller and spinner, prop adapter or motor	Replace damaged parts
	Propeller is out of balance	Balance or replace propeller
	Prop nut is too loose	Tighten the prop nut
Reduced flight time or aircraft underpowered	Flight battery charge is low	Completely recharge flight battery
	Propeller installed backwards	Install propeller with numbers facing forward
	Flight battery damaged	Replace flight battery and follow flight battery instructions
	Flight conditions may be too cold	Make sure battery is warm before use
	Battery capacity too low for flight conditions	Replace battery or use a larger capacity battery
Aircraft will not Bind (during binding) to transmitter	Transmitter too near aircraft during binding process	Move powered transmitter a few feet from aircraft, disconnect and reconnect flight battery to aircraft
	Aircraft or transmitter is too close to large metal object, wireless source or another transmitter	Move aircraft and transmitter to another location and attempt binding again
	The bind plug is not installed correctly in the bind port	Install bind plug in bind port and bind the aircraft to the transmitter
	Flight battery/transmitter battery charge is too low	Replace/recharge batteries
	Bind switch or button not held long enough during bind process	Power off transmitter and repeat bind process. Hold transmitter bind button or switch until receiver is bound
Aircraft will not connect (after binding) to transmitter	Transmitter too near aircraft during connecting process	Move powered transmitter a few feet from aircraft, disconnect and reconnect flight battery to aircraft
	Aircraft or transmitter is too close to large metal object, wireless source or another transmitter	Move aircraft and transmitter to another location and attempt connecting again
	Bind plug left installed in bind port	Rebind transmitter to the aircraft and remove the bind plug before cycling power
	Aircraft bound to different model memory (ModelMatch™ radios only)	Select correct model memory on transmitter
	Flight battery/Transmitter battery charge is too low	Replace/recharge batteries
	Transmitter may have been bound to a different aircraft using different DSM protocol	Bind aircraft to transmitter
Control surface does not move	Control surface, control horn, linkage or servo damage	Replace or repair damaged parts and adjust controls
	Wire damaged or connections loose	Do a check of wires and connections, connect or replace as needed
	Transmitter is not bound correctly or the incorrect airplanes was selected	Re-bind or select correct airplanes in transmitter
	Flight battery charge is low	Fully recharge flight battery
	BEC (Battery Elimination Circuit) of the ESC is damaged	Replace ESC
Controls reversed	Transmitter settings are reversed	Perform the Control Direction Test and adjust the controls on transmitter appropriately
Motor pulses then motor loses power	ESC uses default soft Low Voltage Cutoff (LVC)	Recharge flight battery or replace battery that is no longer performing
	Weather conditions might be too cold	Postpone flight until weather is warmer
	Battery is old, worn out, or damaged	Replace battery
	Battery C rating might be too low	Use recommended battery

Replacement Parts

Part #	Description
EFL-1054	Pushrod Set w/Ball Links; Decathlon 1.2m
EFL-1055	Motor Mount: Decathlon RJG 1.2m, Sportix 1.1m
EFL-1058	Landing Gear Set; Decathlon 1.2m
EFL-1060	Motor Prop Adaptor: Decathlon 1.2m, Sportix 1.1m
EFL-1066	Battery Tray; Decathlon 1.2m
EFL-1068	Main Wheels 53mm: Decathlon 1.2m, Sportix 1.1m
EFL-1069	Hardware Screw Set; Decathlon 1.2m
EFL-1070	Wing Thumb Screws; Decathlon 1.2m
EFL-1071	Control Horn Set; Decathlon 1.2m
EFL-1072	Wheel Axle Set: Decathlon 1.2m, Sportix 1.1m
EFL-1073	Tailwheel Assembly; Decathlon 1.2m
EFL-1074	Servo Covers; Decathlon 1.2m
EFL-1075	Hands-Free Connector Set; Decathlon 1.2m
EFL-1076	Transport Strut Clip; Decathlon 1.2m
EFL-3246	Prop 10x5: Super Decathlon 1.2m
EFL-3247	Fuselage: Super Decathlon 1.2m
EFL-3248	Wing with two servos: Super Decathlon 1.2m
EFL-3249	Horizontal Stabilizer: Super Decathlon 1.2m
EFL-3250	Vertical Fin and Rudder w/LED: Super Decathlon 1.2m
EFL-3251	Cowl with LED: Super Decathlon
EFL-3252	Decal Sheet: Super Decathlon 1.2m
EFL-3253	Hatch: Super Decathlon 1.2m
EFL-3254	Wheel Pants Set: Super Decathlon 1.2m
EFL-3621	Spinner: Super Decathlon 1.2m
SPM-1000	Brushless Outrunner Motor: 3536-1030kv 14-Pole
SPM-1031	AR631+ 6 Channel AS3X+ & SAFE Receiver
SPM-1064	SA348 Servo Arm Assortment
SPMSA348	A348 13g Sub-Micro Metal-Geared Digital Servo
SPMXAE45A	Avian 45A Smart Lite Brushless ESC, 3S-4S IC3

Recommended Items

Part #	Description
SPMX224S50	2200mAh 4S 14.8V Smart G2 LiPo 50C; IC3
SPMXC2020	Smart S1200 G2 AC Charger; 1x200W
SPMXPSA500	Smart Powerstage 4S Air Bundle: (2) G2 2200mAh 4S 50C LiPo IC3 & S250 Charger
SPMR7110	NX7e+ 7 Channel Transmitter Only

Optional Parts

Part #	Description
SPM6730	Smart Charger Case
SPMR7120	NX7e+ Black Edition 14 Channel Transmitter Only
SPMX22003S100	2200mAh 3S 11.1V 100C Smart LiPo Battery; IC3
SPMX22004S30	2200mAh 4S 14.8V Smart LiPo 30C; IC3
SPMX32003S30	3200mAh 3S 11.1V Smart LiPo 30C; IC3
SPMX32004S30	3200mAh 4S 14.8V Smart LiPo Battery 30C; IC3
SPMXBC200	XBC200 Smart Battery Checker & Servo Tester
SPMXC2050	S155 55W AC G2 Smart Charger
SPMXCA300	Smart Lipo Bag, 16 x 7.5 x 6.5 cm

Hardware List

Location	Description	Quantity
Spinner	M2.5 x 8 hex machine screw	1
Prop	M6 nut	1
Prop Adapter	M2.5 x 7 philip machine screw	3
Motor Mount	M3 x 12 hex self-tapping screw	4
Motor	M3 x 6 philip machine screw	4
Cowling	M2 x 8 hex self-tapping screw	4
Battery Tray	M2 x 8 hex self-tapping screw	4
Battery Frame	M2 x 8 hex self-tapping screw	4
Bind Plug	M2 x 8 philip self-tapping screw	1
Front LG Plate	M3 x 10 hex machine screw	6
Wing Strut-Fuselage End	M2 x 15 half-thread machine screw	2
Wing Strut- Wing End	M2 x 10 half-thread machine screw	4
Wheel Pant- Up Hole	M3 x 6 hex machine screw	2
Wheel Pant- Down Hole	M3 x 30 hex half-thread machine screw	2
Wheel Pant -Assembly	M2.5 x 10 hexself-tapping screw	4
Aileron Control Horn	M2 x 8 hex self-tapping screw	4
Wing Strut Mount	M2 x 8 hex self-tapping screw	4
Servo Cover	M2.5 x 10 counter hex self-tapping screw	6
Servo Arm	M2 4.5 philip machine screw	4
Ele/Rud Servos	M2 x 8 hex self-tapping screw	2
Wing	M3 x 25 thumb machine screw	3
Connector	M1.6 x 5 philip countersunk pointed tail self-tapping screw.	4
Hand Free Connector	M2 x 8 philip countersunk pointed tail self-tapping screw.	2
Rudder Assembly-Fuselage Side	M2.5 x 15 hex self-tapping screw	3
Rudder Assembly-Rudder Side	M2 x 8 he self-tapping screw	2
Rudder Plate	M2 x 8 hexself-tapping screw	4
Control Horn Ball Link	M2 self-lock nut	4
Control Horn Ball Link	S4 ball thread M2X5	4

Important Federal Aviation Administration (FAA) Information



Use the QR code to learn more about the Recreational UAS Safety Test (TRUST), as was introduced by the 2018 FAA Reauthorization Bill. This free test is required by the FAA for all recreational flyers in the United States. The completed certificate must be presented upon request by any FAA or law enforcement official.



If your model aircraft weighs more than .55lbs or 250 grams, you are required by the FAA to register as a recreational flyer and apply your registration number to the outside of your aircraft. To learn more about registering with the FAA, use the QR code below.



According to FAA regulation, all unmanned aircraft over .55lbs (250 grams) flying in United States airspace are required to either fly within an FAA-Recognized Identification Area (FRIA) or continually transmit an FAA-registered remote identification from a Remote ID broadcast module, such as the Spektrum™ Sky™ Remote ID module (SPMA9500). Use the QR code to learn more about the FAA Remote ID regulations.

AMA National Model Aircraft Safety Code

Effective January 1, 2018

A model aircraft is a non-human-carrying device capable of sustained flight within visual line of sight of the pilot or spotter(s). It may not exceed limitations of this code and is intended exclusively for sport, recreation, education and/or competition. All model flights must be conducted in accordance with this safety code and related AMA guidelines, any additional rules specific to the flying site, as well as all applicable laws and regulations.

As an AMA member I agree:

- I will not fly a model aircraft in a careless or reckless manner.
- I will not interfere with and will yield the right of way to all human-carrying aircraft using AMA's See and Avoid Guidance and a spotter when appropriate.
- I will not operate any model aircraft while I am under the influence of alcohol or any drug that could adversely affect my ability to safely control the model.
- I will avoid flying directly over unprotected people, moving vehicles, and occupied structures.
- I will fly Free Flight (FF) and Control Line (CL) models in compliance with AMA's safety programming.
- I will maintain visual contact of an RC model aircraft without enhancement other than corrective lenses prescribed to me. When using an advanced flight system, such as an autopilot, or flying First-Person View (FPV), I will comply with AMA's Advanced Flight System programming.
- I will only fly models weighing more than 55 pounds, including fuel, if certified through AMA's Large Model Airplane Program.
- I will only fly a turbine-powered model aircraft in compliance with AMA's Gas Turbine Program.
- I will not fly a powered model outdoors closer than 25 feet to any individual, except for myself or my helper(s) located at the flightline, unless I am taking off and landing, or as otherwise provided in AMA's Competition Regulation.
- I will use an established safety line to separate all model aircraft operations from spectators and bystanders.

Limited Warranty

What this Warranty Covers

Horizon Hobby, LLC, (Horizon) warrants to the original purchaser that the product purchased (the "Product") will be free from defects in materials and workmanship at the date of purchase.

What is Not Covered

This warranty is not transferable and does not cover (i) cosmetic damage, (ii) damage due to acts of God, accident, misuse, abuse, negligence, commercial use, or due to improper use, installation, operation or maintenance, (iii) modification of or to any part of the Product, (iv) attempted service by anyone other than a Horizon Hobby authorized service center, (v) Product not purchased from an authorized Horizon dealer, (vi) Product not compliant with applicable technical regulations, or (vii) use that violates any applicable laws, rules, or regulations.

OTHER THAN THE EXPRESS WARRANTY ABOVE, HORIZON MAKES NO OTHER WARRANTY OR REPRESENTATION, AND HEREBY DISCLAIMS ANY AND ALL IMPLIED WARRANTIES, INCLUDING, WITHOUT LIMITATION, THE IMPLIED WARRANTIES OF NON-INFRINGEMENT, MERCHANTABILITY AND FITNESS FOR A PARTICULAR PURPOSE. THE PURCHASER ACKNOWLEDGES THAT THEY ALONE HAVE DETERMINED THAT THE PRODUCT WILL SUITABLY MEET THE REQUIREMENTS OF THE PURCHASER'S INTENDED USE.

Purchaser's Remedy

Horizon's sole obligation and purchaser's sole and exclusive remedy shall be that Horizon will, at its option, either (i) service, or (ii) replace, any Product determined by Horizon to be defective. Horizon reserves the right to inspect any and all Product(s) involved in a warranty claim. Service or replacement decisions are at the sole discretion of Horizon. Proof of purchase is required for all warranty claims. SERVICE OR REPLACEMENT AS PROVIDED UNDER THIS WARRANTY IS THE PURCHASER'S SOLE AND EXCLUSIVE REMEDY.

Limitation of Liability

HORIZON SHALL NOT BE LIABLE FOR SPECIAL, INDIRECT, INCIDENTAL OR CONSEQUENTIAL DAMAGES, LOSS OF PROFITS OR PRODUCTION OR COMMERCIAL LOSS IN ANY WAY, REGARDLESS OF WHETHER SUCH CLAIM IS BASED IN CONTRACT, WARRANTY, TORT, NEGLIGENCE, STRICT LIABILITY OR ANY OTHER THEORY OF LIABILITY, EVEN IF HORIZON HAS BEEN ADVISED OF THE POSSIBILITY OF SUCH DAMAGES. Further, in no event shall the liability of Horizon exceed the individual price of the Product on which liability is asserted. As Horizon has no control over use, setup, final assembly, modification or misuse, no liability shall be assumed nor accepted for any resulting damage or injury. By the act of use, setup or assembly, the user accepts all resulting liability. If you as the purchaser or user are not prepared to accept the liability associated with the use of the Product, purchaser is advised to return the Product immediately in new and unused condition to the place of purchase.

Law

These terms are governed by Illinois law (without regard to conflict of law principals). This warranty gives you specific legal rights, and you may also have other rights which vary from state to state. Horizon reserves the right to change or modify this warranty at any time without notice.

WARRANTY SERVICES

Questions, Assistance, and Services

Your local hobby store and/or place of purchase cannot provide warranty support or service. Once assembly, setup or use of the Product has been started, you must contact your local distributor or Horizon directly. This will enable Horizon

to better answer your questions and service you in the event that you may need any assistance. For questions or assistance, please visit our website at www.horizonhobby.com, submit a Product Support Inquiry, or call the toll free telephone number referenced in the Warranty and Service Contact Information section to speak with a Product Support representative.

Inspection or Services

If this Product needs to be inspected or serviced and is compliant in the country you live and use the Product in, please use the Horizon Online Service Request submission process found on our website or call Horizon to obtain a Return Merchandise Authorization (RMA) number. Pack the Product securely using a shipping carton. Please note that original boxes may be included, but are not designed to withstand the rigors of shipping without additional protection. Ship via a carrier that provides tracking and insurance for lost or damaged parcels, as Horizon is not responsible for merchandise until it arrives and is accepted at our facility. An Online Service Request is available at http://www.horizonhobby.com/content/service-center_render-service-center. If you do not have internet access, please contact Horizon Product Support to obtain a RMA number along with instructions for submitting your product for service. When calling Horizon, you will be asked to provide your complete name, street address, email address and phone number where you can be reached during business hours. When sending product into Horizon, please include your RMA number, a list of the included items, and a brief summary of the problem. A copy of your original sales receipt must be included for warranty consideration. Be sure your name, address, and RMA number are clearly written on the outside of the shipping carton.

NOTICE: Do not ship LiPo batteries to Horizon. If you have any issue with a LiPo battery, please contact the appropriate Horizon Product Support office.

Warranty Requirements

For Warranty consideration, you must include your original sales receipt verifying the proof-of-purchase date. Provided warranty conditions have been met, your Product will be serviced or replaced free of charge. Service or replacement decisions are at the sole discretion of Horizon.

Non-Warranty Service

Should your service not be covered by warranty, service will be completed and payment will be required without notification or estimate of the expense unless the expense exceeds 50% of the retail purchase cost. By submitting the item for service you are agreeing to payment of the service without notification. Service estimates are available upon request. You must include this request with your item submitted for service. Non-warranty service estimates will be billed a minimum of ½ hour of labor. In addition you will be billed for return freight. Horizon accepts money orders and cashier's checks, as well as Visa, MasterCard, American Express, and Discover cards. By submitting any item to Horizon for service, you are agreeing to Horizon's Terms and Conditions found on our website http://www.horizonhobby.com/content/service-center_render-service-center.

ATTENTION: Horizon service is limited to Product compliant in the country of use and ownership. If received, a non-compliant Product will not be serviced. Further, the sender will be responsible for arranging return shipment of the un-serviced Product, through a carrier of the sender's choice and at the sender's expense. Horizon will hold non-compliant Product for a period of 60 days from notification, after which it will be discarded.

10/15

Contact Information

Country of Purchase	Horizon Hobby	Contact Information	Address
United States of America	Horizon Service Center (Repairs and Repair Requests)	servicecenter.horizonhobby.com/RequestForm/	2904 Research Rd Champaign, Illinois, 61822 USA
	Horizon Product Support (Product Technical Assistance)	productsupport@horizonhobby.com 877-504-0233	
	Sales	websales@horizonhobby.com 800-338-4639	
European Union	Horizon Technischer Service Sales: Horizon Hobby GmbH	service@horizonhobby.de +49 (0) 4121 2655 100	Hanskampring 9 D 22885 Barsbüttel, Germany

FCC Information

FCC ID: BRWSPMSR6200A

Supplier's Declaration of Conformity

FC EFL Super Decathlon 1.2M V2 BNF Basic and PNP (EFL20550/ EFL20575)

This device complies with part 15 of the FCC Rules. Operation is subject to the following two conditions: (1) This device may not cause harmful interference, and (2) this device must accept any interference received, including interference that may cause undesired operation.

CAUTION: Changes or modifications not expressly approved by the party responsible for compliance could void the user's authority to operate the equipment.

NOTE: This equipment has been tested and found to comply with the limits for a Class B digital device, pursuant to part 15 of the FCC Rules. These limits are designed to provide reasonable protection against harmful interference in a residential installation. This equipment generates, uses and can radiate radio

frequency energy and, if not installed and used in accordance with the instructions, may cause harmful interference to radio communications. However, there is no guarantee that interference will not occur in a particular installation. If this equipment does cause harmful interference to radio or television reception, which can be determined by turning the equipment off and on, the user is encouraged to try to correct the interference by one or more of the following measures:

- Reorient or relocate the receiving antenna.
- Increase the separation between the equipment and receiver.
- Connect the equipment into an outlet on a circuit different from that to which the receiver is connected.
- Consult the dealer or an experienced radio/TV technician for help.

Horizon Hobby, LLC
2904 Research Rd.,
Champaign, IL 61822
Email: compliance@horizonhobby.com
Web: HorizonHobby.com

IC Information

IC: 6157A-SPMSR6200A
CAN ICES-3 (B)/NMB-3(B)

This device contains license-exempt transmitter(s)/receiver(s) that comply with Innovation, Science, and Economic Development Canada's license-exempt RSS(s). Operation is subject to the following 2 conditions:

1. This device may not cause interference.
2. This device must accept any interference, including interference that may cause undesired operation of the device.

Compliance Information for the European Union



EU Compliance Statement:

EFL Super Decathlon 1.2M V2 PNP (EFL20575); Hereby, Horizon Hobby, LLC declares that the device is in compliance with the following: EU EMC Directive 2014/30/EU, RoHS 2 Directive 2011/65/EU, RoHS 3 Directive - Amending 2011/65/EU Annex II 2015/863

EFL Super Decathlon 1.2M V2 BNF Basic (EFL20550); Hereby, Horizon Hobby, LLC declares that the device is in compliance with the following: EU Radio Equipment Directive 2014/53/EU, RoHS 2 Directive 2011/65/EU, RoHS 3 Directive - Amending 2011/65/EU Annex II 2015/863

The full text of the EU declaration of conformity is available at the following internet address: <https://www.horizonhobby.com/content/support-render-compliance>.

Wireless Frequency Range and Wireless Output Power:

2404-2476MHz
5.58dBm

EU Manufacturer of Record:

Horizon Hobby, LLC
2904 Research Road
Champaign, IL 61822 USA

EU Importer of Record:

Horizon Hobby, GmbH
Hanskampring 9
22885 Barsbüttel Germany

WEEE NOTICE:



This appliance is labeled in accordance with European Directive 2012/19/EU concerning waste of electrical and electronic equipment (WEEE). This label indicates that this product should not be disposed of with household waste. It should be deposited at an appropriate facility to enable recovery and recycling.





©2026 Horizon Hobby, LLC.

E-flite, Plug-N-Play, Bind-N-Fly, BNF, the BNF logo, DSM, DSM2, DSMX, Spektrum AirWare, IC3, IC5, AS3X+, SAFE, the SAFE logo, ModelMatch, and the Horizon Hobby logo are trademarks or registered trademarks of Horizon Hobby, LLC.

The Spektrum trademark is used with permission of Bachmann Industries, Inc. All other trademarks, service marks and logos are property of their respective owners.

US 8,672,726 US 9,056,667 US 9,753,457. US 10,078,329. US 9,930,567. US 10,419,970. Other patents pending.

<http://www.horizonhobby.com/>

EFL20550, EFL20575