



Platinum .12 SG Owner's Manual

Congratulations on your purchase of a Dynamite® Platinum Series (DPS™) .12 racing engine! Precision manufactured and assembled, your DPS 12 will provide you with trouble-free performance if you read and follow these instructions.

Using the Proper Fuel and Glow Plug

Using the proper fuel and glow plug is critical in order to achieve maximum performance and reliability. You must use fuel, glow plugs and air filters that are specifically designed for model car/truck/buggy applications. **Never use any type of model airplane glow fuel!** Use of model airplane fuel can damage your engine and immediately void any warranty.

We recommend using Dynamite Blue Thunder™ Race Formula fuel with 20% nitro, providing the best combination of power and fuel economy. Dynamite Blue Thunder fuels are vigorously tested, researched and formulated to deliver excellent power as well as engine protection.

A glow plug has been included and is ideal for breaking in your new engine. In fact, during the break-in procedure, it is not uncommon to go through one or two glow plugs, as microscopic bits of metal (from the cylinder/piston wearing in) bond themselves to the plug element causing glow plug failure. We recommend the Dynamite McCoy MC59 Glow Plug (DYN2508) as the absolute best glow plug for this engine. The MC59 Plug has been designed to deliver an ideal balance of performance and longevity.

All car engines must use a properly oiled air filter to keep dirt out of the engine. Any dirt that enters the carburetor can immediately destroy your engine. We recommend DYN2612 as an excellent choice for a quality air cleaner.

Carburetor Adjustments

Your DPS 21 engine comes equipped with a precision rotary carburetor. Take a moment to review the pictures below to familiarize yourself with the various functions of the carb. Loosening the nut located on the side of the crankcase under the carburetor body will allow you to rotate the carburetor. Make certain to mount the throttle arm to the side required by your particular vehicle. Although preset at the factory, some changes in the needle setting can occur during shipping and handling.

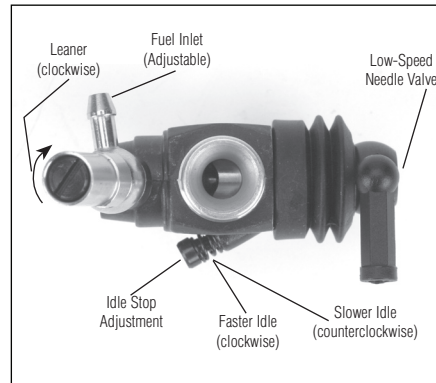
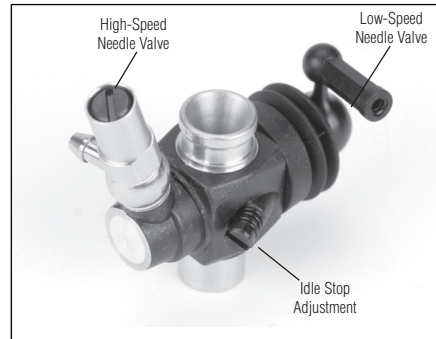

Needle Settings

We suggest the following settings for breaking in your engine:

High-Speed Needle: 2 turns out (counterclockwise) from closed.

Low-Speed Needle: 1 turn out (counterclockwise) from closed.

When checking the adjustment of the low-speed needle, it is crucial that the throttle slide is closed completely when turning the needle and that you do not over-tighten the needle. Use an engine tuning screwdriver to make this job easier. When you feel resistance in the needle, immediately stop turning and begin turning the needles counterclockwise, counting the number of turns from “closed.”

Starting Your Engine for the First Time

The first start of your engine is the most critical time of the engine's life, dictating how well it will perform. After installing the engine in your model and inserting the glow plug, turn on your radio system and attach a glow igniter to the glow plug. Place your vehicle on top of your starter box and engage the flywheel to your starter wheel. Should the engine become difficult for your starter box to turn over, the engine may be flooded (hydro-locked). Excess fuel between the cylinder head and piston will not allow the piston to travel through its full range of compression, effectively “locking up” the engine. Should this occur, immediately remove the glow igniter from the plug. Using a glow plug wrench (DYN2510), remove the glow plug and turn the model upside down and rotate the flywheel to clear out the fuel, re-install the glow plug and start again.

We recommend using the DYNP5300 Quick-Fire Universal Starter Box to start your DPS .12. You may need to “blip” the throttle on the transmitter (applying throttle on/off) while trying to start the engine, as new engines are more difficult to start due to the tight piston/cylinder fit.

Never start an engine above 1/4 throttle. Immediate damage to your engine can and will occur.

When the engine starts, the exhaust should emit lots of blue/white smoke, indicating that the engine is excessively rich (a good thing during break in). During the first tank of fuel, you may wish to set a higher than normal idle speed and/or leave the glow plug igniter attached in order to keep the engine from stalling. Drive your vehicle around while “blipping” the throttle and avoid operating the engine at full throttle for more than 2–3 seconds at a time. Consume the entire first two tanks of fuel in this manner. After the first two tanks of fuel, begin leaning out the high-speed needle valve 1/8 turn at a time. It generally takes about 5 or 6 tanks of fuel before you'd want to start tuning for “maximum” power.

Do not skip this process of breaking in a new engine! Should you choose not to follow these procedures, you risk damaging your engine during the first tank of fuel.

Your patience during these procedures will be rewarded by an engine that performs reliably and to its maximum power potential. First run attempts can be more frustrating than with other (less powerful) sport engines, so take your time—it will be worth the wait. Glow plug failure is a common occurrence when breaking in a new engine. To test your plug, let the engine idle at a properly adjusted low-speed needle setting with the glow igniter attached. Then, remove the igniter. If you hear no appreciable change in engine rpm, the plug is still good. If the engine loads up and the rpm's decrease, it's time to replace the glow plug.

Setting the Needle Valves

When tuning the needle valves for maximum performance, adjust them in small increments, 1/16 turn at a time.

An engine should not be run too lean; doing so severely shortens the life of the engine. When an engine is set too lean, it will run very strong at first but will soon begin to sag and hesitate or stall when accelerating.

The best way to tune an engine is by using an infrared temperature gauge, but you can also use water to check the head temperature (refer to "Tuning the High-Speed Needle").

Tuning the High-Speed Needle

To obtain the correct high-speed needle setting, start the engine and drive your vehicle around for a minute or two, applying full throttle frequently. Place a drop of water on the cylinder head. If the water sizzles away (evaporates immediately), the needle setting is too lean. A correct needle setting will result in the water evaporating after 3-5 seconds. If the water does not evaporate, chances are good that the needle setting is too rich. Lean the needle 1/16 of a turn and run the engine again, adjusting the needle setting to get the desired evaporation time.

Check the temperature each time you change the needle mixture. Do not let the engine overheat, as this will damage the engine.

Tuning the Low-Speed Needle

The low-speed needle (also referred to as the idle mixture or idle needle) should be set after you're satisfied with the high-speed needle setting. After achieving the proper operating temperature, reduce the engine throttle to idle and pinch the fuel line with your fingers close to the carb fuel inlet nipple. If the engine dies immediately, the low-speed needle is set too lean. If the rpm's increase dramatically, the setting is too rich. The ideal setting results in the rpm's increasing just a slight amount after pinching the fuel line.

Idle Stop Adjustment

The last setting to be made is the idle stop screw. Turning this screw clockwise increases the idle speed, whereas turning the screw counterclockwise will make the engine idle at a lower speed. Ideally, the engine should idle just fast enough to be reliable in acceleration and transition from idle to full speed. Avoid an idle speed that is too fast, as it will cause damage to your clutch.

Engine Maintenance

Periodic maintenance must be performed in order to keep your engine in proper operating condition. After each day of running, it's critical to use high quality after-run oil to protect the internals of the engine and help prevent corrosion. The methanol used in the fuel attracts moisture that can cause corrosion (particularly in the ball bearings). Follow these steps after running your engine:

- 1) Empty all fuel from the tank and fuel lines.
- 2) Remove the glow plug and air filter and add 5 to 6 drops of a quality after-run oil into the carburetor and cylinder head openings. Turn the engine over a few times to distribute the oil throughout the engine.
- 3) Clean and inspect the engine, air cleaner and fuel system.

Troubleshooting Guide

<u>Problem</u>	<u>Possible Cause/Solution</u>
Engine won't start	<ul style="list-style-type: none">• Clogged fuel line• Bad or improper glow plug• Glow igniter not charged
Engine starts, then dies	<ul style="list-style-type: none">• Engine flooded• Pressure line blocked or disconnected• Bad glow plug
Engine starts and runs for 1/2 tank, then quits	<ul style="list-style-type: none">• High-speed needle too lean• Hole or tear in fuel line• Bad glow plug or idle speed set too low• Overheated engine (too lean)• Improper needle settings

Warranty Period:

Exclusive Warranty- Horizon Hobby, Inc., (Horizon) warranties that the Products purchased (the "Product") will be free from defects in materials and workmanship at the date of purchase by the Purchaser.

Limited Warranty

(a) This warranty is limited to the original Purchaser ("Purchaser") and is not transferable. REPAIR OR REPLACEMENT AS PROVIDED UNDER THIS WARRANTY IS THE EXCLUSIVE REMEDY OF THE PURCHASER. This warranty covers only those Products purchased from an authorized Horizon dealer. Third party transactions are not covered by this warranty. Proof of purchase is required for warranty claims. Further, Horizon reserves the right to change or modify this warranty without notice and disclaims all other warranties, express or implied.

(b) Limitations- HORIZON MAKES NO WARRANTY OR REPRESENTATION, EXPRESS OR IMPLIED, ABOUT NON-INFRINGEMENT, MERCHANTABILITY OR FITNESS FOR A PARTICULAR PURPOSE OF THE PRODUCT. THE PURCHASER ACKNOWLEDGES THAT THEY ALONE HAVE DETERMINED THAT THE PRODUCT WILL SUITABLY MEET THE REQUIREMENTS OF THE PURCHASER'S INTENDED USE.

(c) Purchaser Remedy- Horizon's sole obligation hereunder shall be that Horizon will, at its option, (i) repair or (ii) replace, any Product determined by Horizon to be defective. In the event of a defect, these are the Purchaser's exclusive remedies. Horizon reserves the right to inspect any and all equipment involved in a warranty claim. Repair or replacement decisions are at the sole discretion of Horizon. This warranty does not cover cosmetic damage or damage due to acts of God, accident, misuse, abuse, negligence, commercial use, or modification of or to any part of the Product. This warranty does not cover damage due to improper installation, operation, maintenance, or attempted repair by anyone other than Horizon. Return of any goods by Purchaser must be approved in writing by Horizon before shipment.

Damage Limits

HORIZON SHALL NOT BE LIABLE FOR SPECIAL, INDIRECT OR CONSEQUENTIAL DAMAGES, LOSS OF PROFITS OR PRODUCTION OR COMMERCIAL LOSS IN ANY WAY CONNECTED WITH THE PRODUCT, WHETHER SUCH CLAIM IS BASED IN CONTRACT, WARRANTY, NEGLIGENCE, OR STRICT LIABILITY. Further, in no event shall the liability of Horizon exceed the individual price of the Product on which liability is asserted. As Horizon has no control over use, setup, final assembly, modification or misuse, no liability shall be assumed nor accepted for any resulting damage or injury. By the act of use, setup or assembly, the user accepts all resulting liability.

If you as the Purchaser or user are not prepared to accept the liability associated with the use of this Product, you are advised to return this Product immediately in new and unused condition to the place of purchase.

Law: These Terms are governed by Illinois law (without regard to conflict of law principals).

Safety Precautions

This is a sophisticated hobby Product and not a toy. It must be operated with caution and common sense and requires some basic mechanical ability. Failure to operate this Product in a safe and responsible manner could result in injury or damage to the Product or other property. This Product is not intended for use by children without direct adult supervision. The Product manual contains instructions for safety, operation and maintenance. It is essential to read and follow all the instructions and warnings in the manual, prior to assembly, setup or use, in order to operate correctly and avoid damage or injury.

Questions, Assistance, and Repairs

Your local hobby store and/or place of purchase cannot provide warranty support or repair. Once assembly, setup or use of the Product has been started, you must contact Horizon directly. This will enable Horizon to better answer your questions and service you in the event that you may need any assistance. For questions or assistance, please direct your email to productsupport@horizonhobby.com, or call 877.504.0233 toll free to speak to a service technician.

Inspection or Repairs

If this Product needs to be inspected or repaired, please call for a Return Merchandise Authorization (RMA). Pack the Product securely using a shipping carton. Please note that original boxes may be included, but are not designed to withstand the rigors of shipping without additional protection. Ship via a carrier that provides tracking and insurance for lost or damaged parcels, as **Horizon is not responsible for merchandise until it arrives and is accepted at our facility.** A Service Repair Request is available at www.horizonhobby.com on the "Support" tab. If you do not have internet access, please include a letter with your complete name, street address, email address and phone number where you can be reached during business days, your RMA number, a list of the included items, method of payment for any non-warranty expenses and a brief summary of the problem. Your original sales receipt must also be included for warranty consideration. Be sure your name, address, and RMA number are clearly written on the outside of the shipping carton.

Warranty Inspection and Repairs

To receive warranty service, you must include your original sales receipt verifying the proof-of-purchase date. Provided warranty conditions have been met, your Product will be repaired or replaced free of charge. Repair or replacement decisions are at the sole discretion of Horizon Hobby.

Non-Warranty Repairs

Should your repair not be covered by warranty the repair will be completed and payment will be required without notification or estimate of the expense unless the expense exceeds 50% of the retail purchase cost. By submitting the item for repair you are agreeing to payment of the repair without notification. Repair estimates are available upon request. You must include this request with your repair. Non-warranty repair estimates will be billed a minimum of ½ hour of labor. In addition you will be billed for return freight. Please advise us of your preferred method of payment. Horizon accepts money orders and cashiers checks, as well as Visa, MasterCard, American Express, and Discover cards. If you choose to pay by credit card, please include your credit card number and expiration date. Any repair left unpaid or unclaimed after 90 days will be considered abandoned and will be disposed of accordingly. **Please note: non-warranty repair is only available on electronics and model engines.**

Electronics and engines requiring inspection or repair should be shipped to the following address:

**Horizon Service Center
4105 Fieldstone Road
Champaign, Illinois 61822**

All other Products requiring warranty inspection or repair should be shipped to the following address:

**Horizon Product Support
4105 Fieldstone Road
Champaign, Illinois 61822**

Please call 877-504-0233 with any questions or concerns regarding this product or warranty.

© 2007 Horizon Hobby, Inc.

Dynamite engines are manufactured in Taiwan and distributed worldwide by:

Horizon Hobby, Inc.
4105 Fieldstone Rd.
Champaign, IL 61822
www.horizonhobby.com



DPS .12

REAR EXHAUST

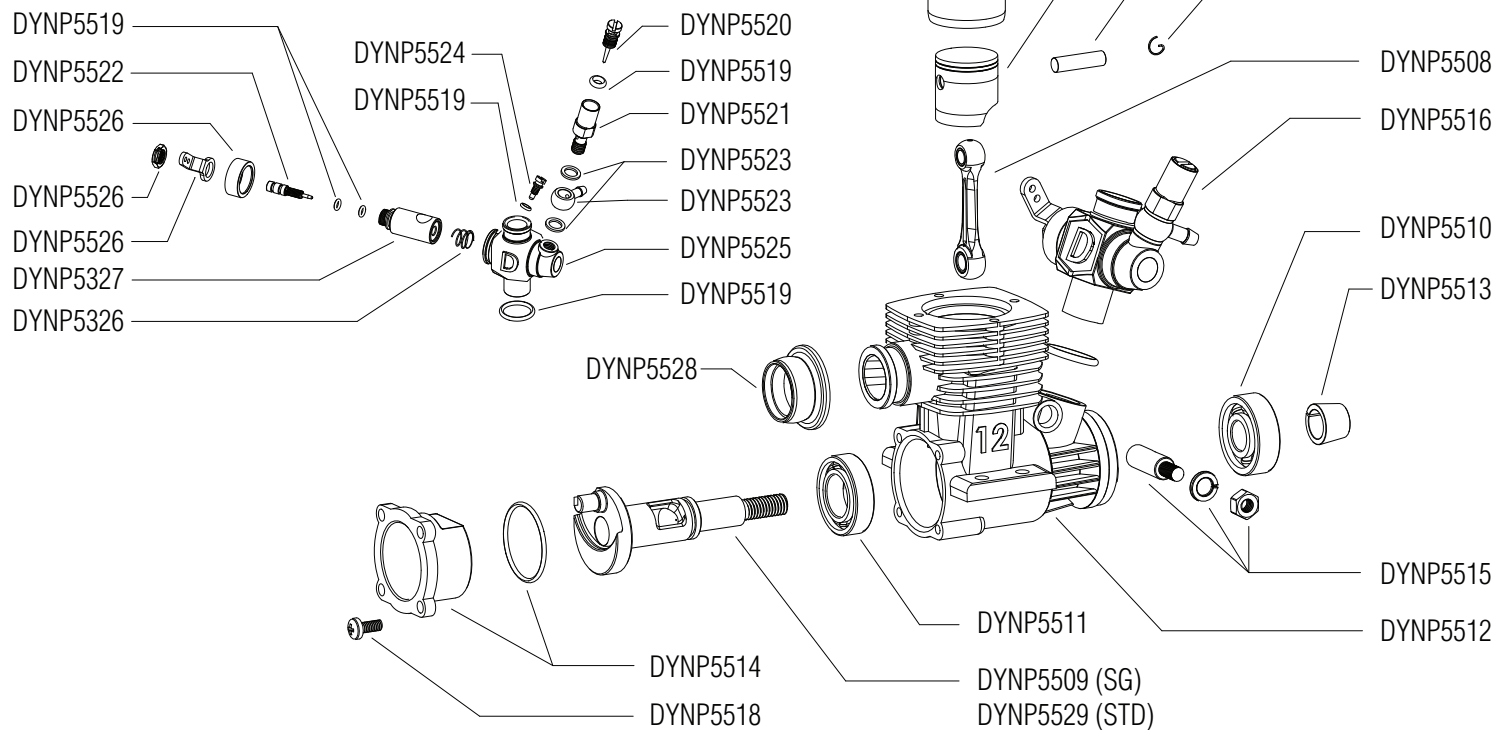

Spare Parts Listing

Stock #	Description
DYNP5501	CYLINDER HEAD, BLUE: DPS 12
DYNP5502	HEAD BUTTON: DPS 12
DYNP5503	HEAD SHIM .1MM (3): DPS 12
DYNP5504	HEAD SHIM .2MM (3): DPS 12
DYNP5505	PISTON / SLEEVE (3-PORT): DPS 12
DYNP5506	WRIST PIN: DPS 12
DYNP5507	WRIST PIN CLIPS (2): DPS 12
DYNP5508	CONNECTING ROD: DPS 12
DYNP5509	CRANKSHAFT, SG: DPS 12
DYNP5510	FRONT BEARING 7x19x6: DPS 12
DYNP5511	REAR BEARING : DPS 12
DYNP5512	CRANKCASE: DPS 12
DYNP5513	COLLET: DPS 12
DYNP5514	BACKPLATE w/O-RING: DPS 12
DYNP5515	CARB RETAINER POST: DPS 12
DYNP5516	ROTARY CARBURETOR: DPS 12
DYNP5517	HEAD SCREWS 2.6x12 (4): DPS 12
DYNP5518	BACKPLATE SCREWS 2.6 X 8MM (4): DPS 12
DYNP5319	2 NEEDLE CARB O-RING SET: DPS 12
DYNP5520	HIGH SPEED ADJ. NEEDLE: DPS 12
DYNP5521	HIGH SPEED NEEDLE HOLDER: DPS 12
DYNP5522	LOW SPEED ADJ. NEEDLE: DPS 12
DYNP5523	FUEL INLET NIPPLE/WASHERS: DPS 12
DYNP5524	IDLE SCREW: DPS 12
DYNP5525	CARB BODY: DPS 12
DYNP5326	THROTTLE LEVER/BOOT/SPRING/NUT: DPS 12