

VIKING LONG SHIP , 11th century

SCALE: 1/72
length: 390mm
width: 185mm
Height: 236mm

HISTORY:	1
List of recommended tools:.....	1
Before the start of construction:	2
Color:.....	2
Model building procedure:	3
I) The skeleton of the hull:	3
II) Planking the hull:	4
III) Planking the decks:	6
IV) Rowers Seats:.....	7
V) Stand:	8
VI) Mast footing:.....	8
VII) The steering oar:	9
VIII) Openings in the hull:	9
IX) Mast:	10
X) yard:	11
XI) Sail:	12
XII) Shields:	15
XIII) Oars:	15
Parts List:.....	16

HISTORY:

This model represents the similar longship which was found near the village of Skuldelev at Denmark and which is known as Skuldelev 2. The original was constructed primarily of oak wood about the year 1060 in Dublin. The ship had a length of 30 meters and width of 3.8 meters. The ship could sail with 60-100 Viking warriors onboard and was driven by a large rectangular sheet. In the case of no wind, there were 60 oars.

List of recommended tools:

- 1) Modeller knife or scalpel
- 2) Mini Drill
- 3) Drill - 1 mm and 2 mm diameter
- 4) Sandpaper - different coarseness
- 5) Scissors
- 6) Tweezers
- 7) Clothes pegs
- 8) Pencil
- 9) Ruler
- 10) A set of needle nail files
- 11) Sewing Machine
- 12) Mini Lathe

Before the start of construction:

Before the start of construction, it is necessary to carefully read the building instructions to ensure the steps for the order of assembly are clearly understood. Cut out the individual parts from the sheets carefully with a sharp knife. Before gluing parts, check if each individual part to be bonded actually fits, and if not, make corrections. During glueing, dyeing, painting and working with other chemicals, it is recommended that you are working in an area which is thoroughly ventilated.

Color:

In medieval ships, to protect the hull from the effects of sea water and wood pests, coated mixtures based on tar were used which were a red brown or dark brown color. The model can achieve this effect by staining the parts of the hull with dark stains. The Parts should be stained before gluing them. The deck was in the original color of wood, so it is sufficient to wipe the boards with clear varnish.

Model building procedure:

1) The framing of the hull:

a) First glue keel from parts 0a-0c. Then on both sides of the keel 0 draw the stylus as shown in the diagram 1a.

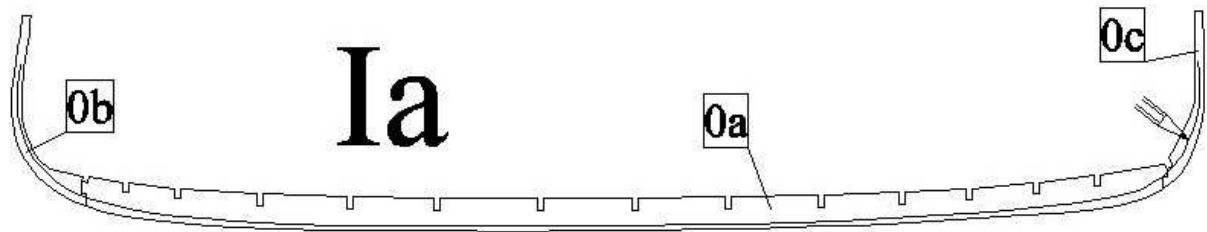

b) Attach ribs 1 to 13 to deck 14 in the following order. 7, 8, 6, 9, 5, 10, 4, 11, 3, 12, 2, 13, 1 and then attach completed deck 14 to keel 0 as shown in diagram 1b.

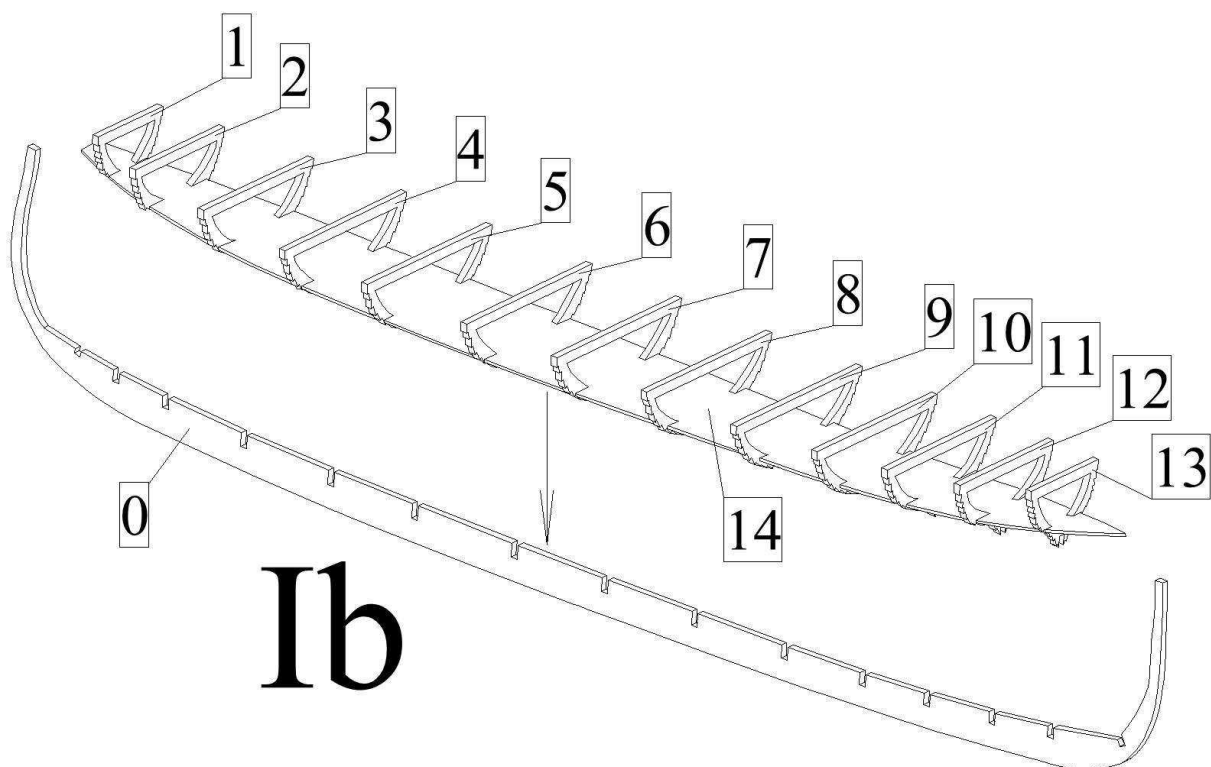

c) Attach ribs 15 and 16 to keel 0 as shown in diagram Ic.

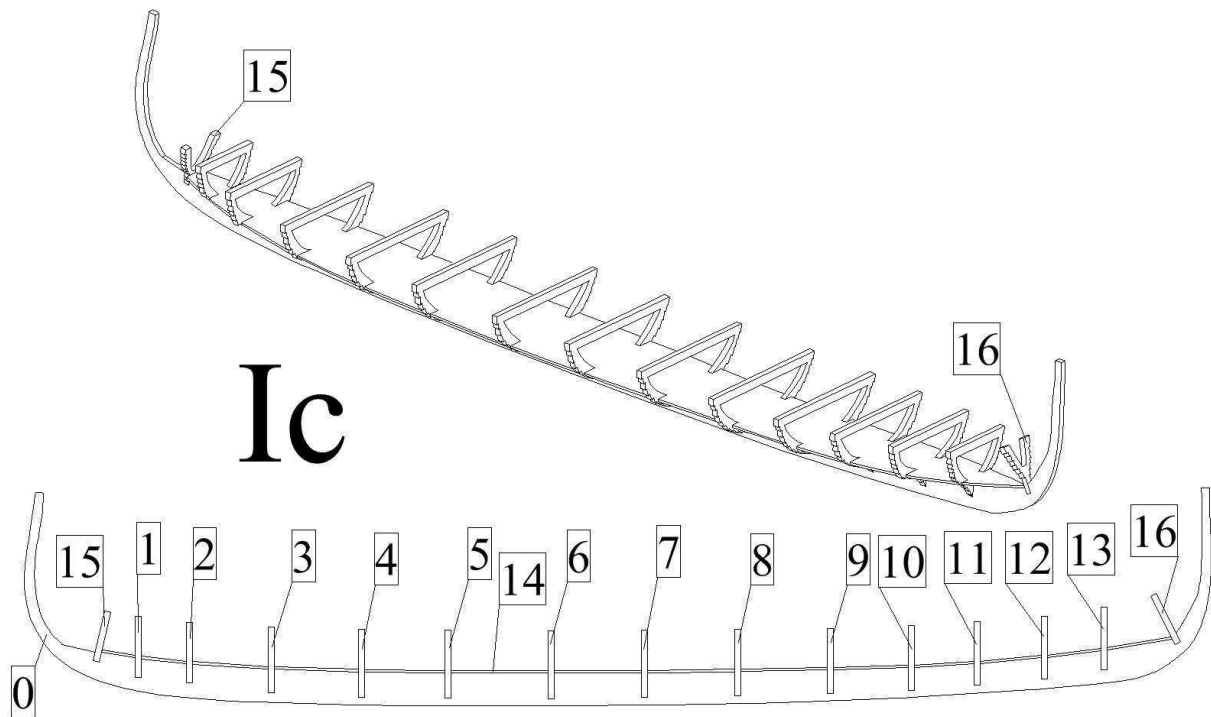

II) Planking the hull:

a) The method of making the hull of Viking ships was known as clinker planking, which is a method where individual planks overlap themselves. It is therefore necessary to strictly comply with the order in which you stick the planks to the ribs. The first step is to glue the planks to the bottom of the hull. Before gluing the planks to stem and stern, slightly grind down the ends of them to fit snugly to it. After sticking planks 17 to starboard and port, follow similarly in bonding planks 18-28. As already mentioned, planks must be stuck gradually in order of 18-28 to have them overlap as shown in diagram IIa.

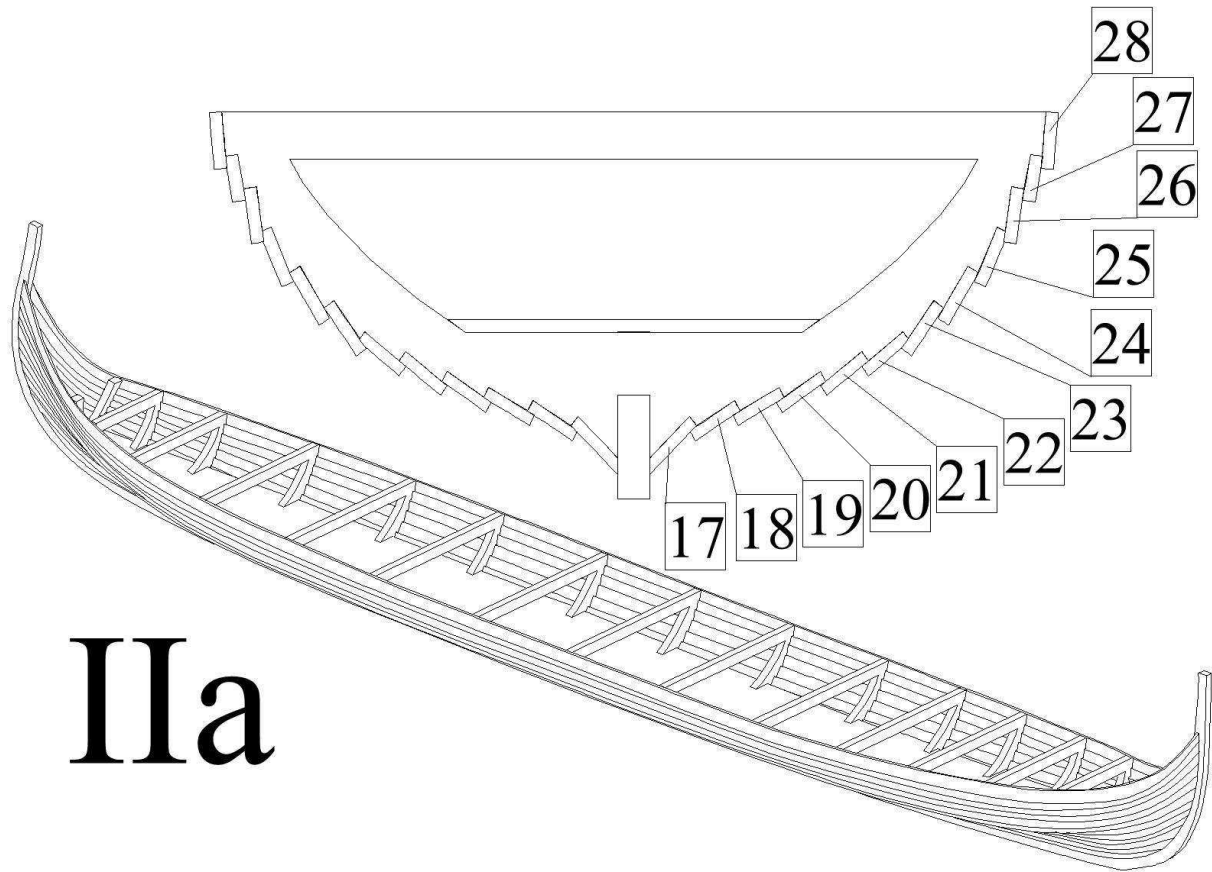

IIa

b) Cut off the parts of ribs 1-13, which overlap overboard. Attention! Ribs 15 and 16 leave in the original state.

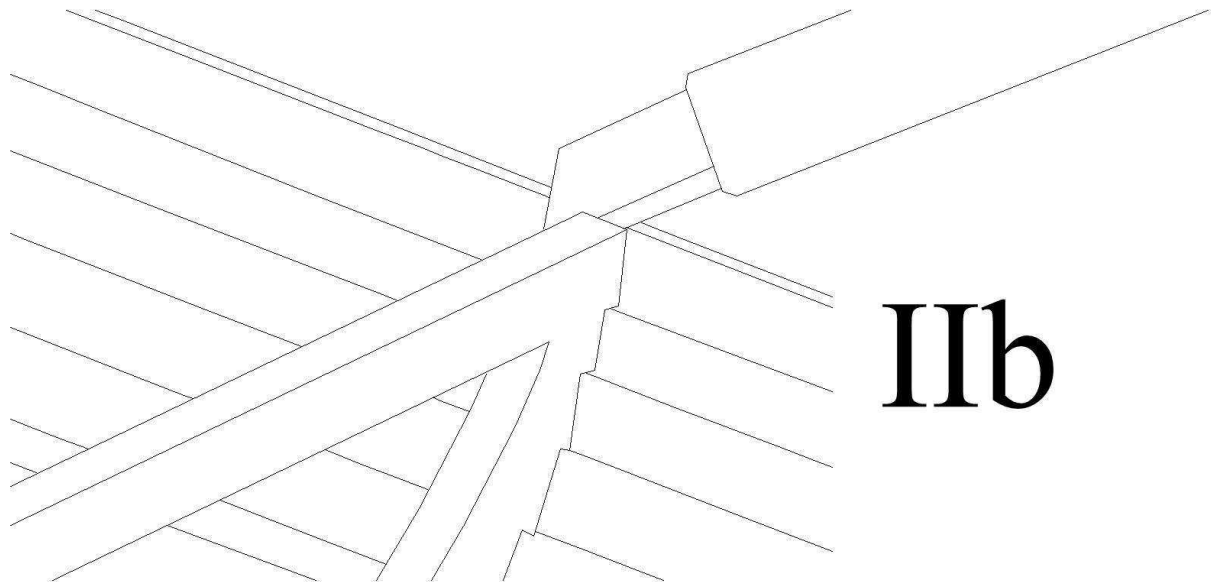

IIb

III) Planking the decks:

a) First glue deck 30 to the deck 14. On the inner side of the hull, attach stiffening beams 31 to planks 25 and 28 as shown in diagram IIIa.

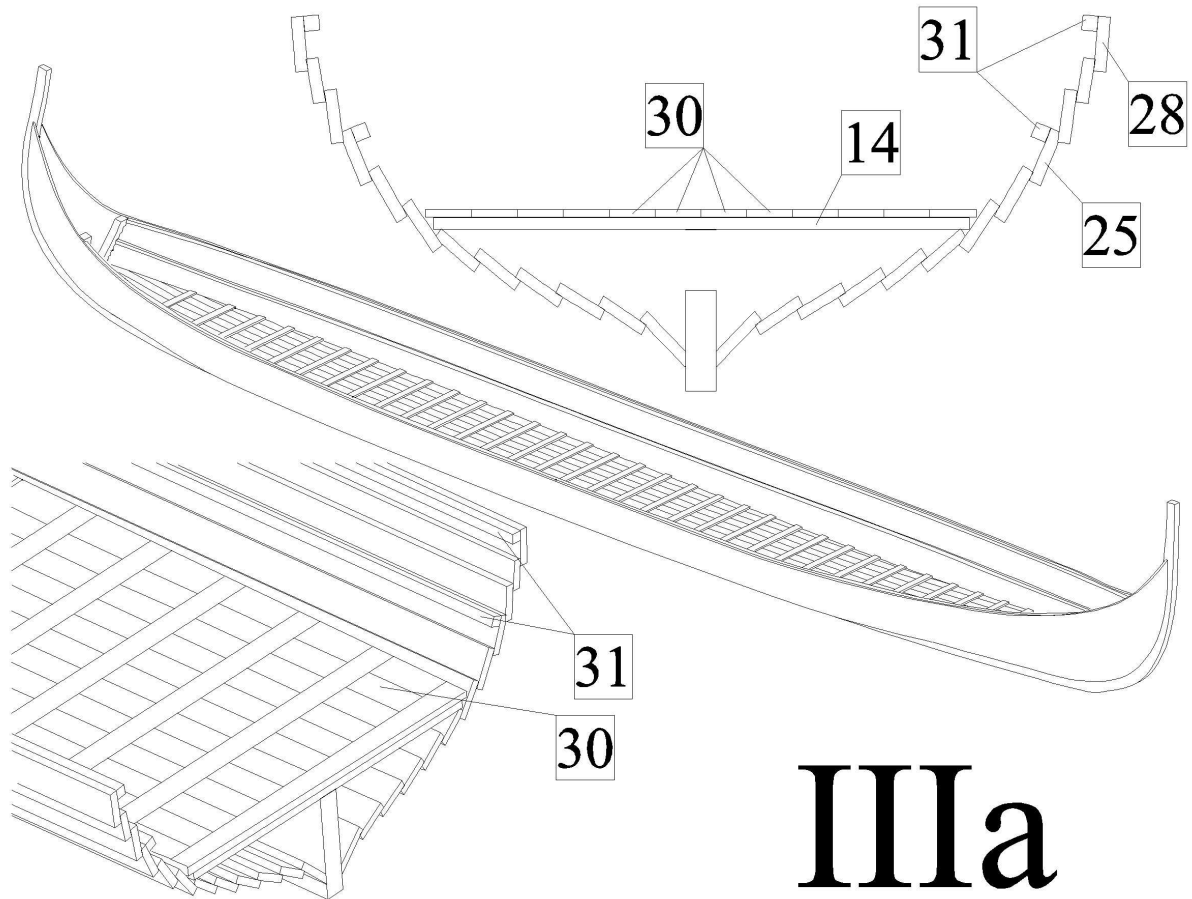

IV) Rowers Seats:

a) On the inside of the hull attach components 32, at the precise location as displayed at 1:1 scale in plan 1.
Then attach the cross girders rower's seats 33. The exact location for the rowers is also shown at 1:1 scale in plan.

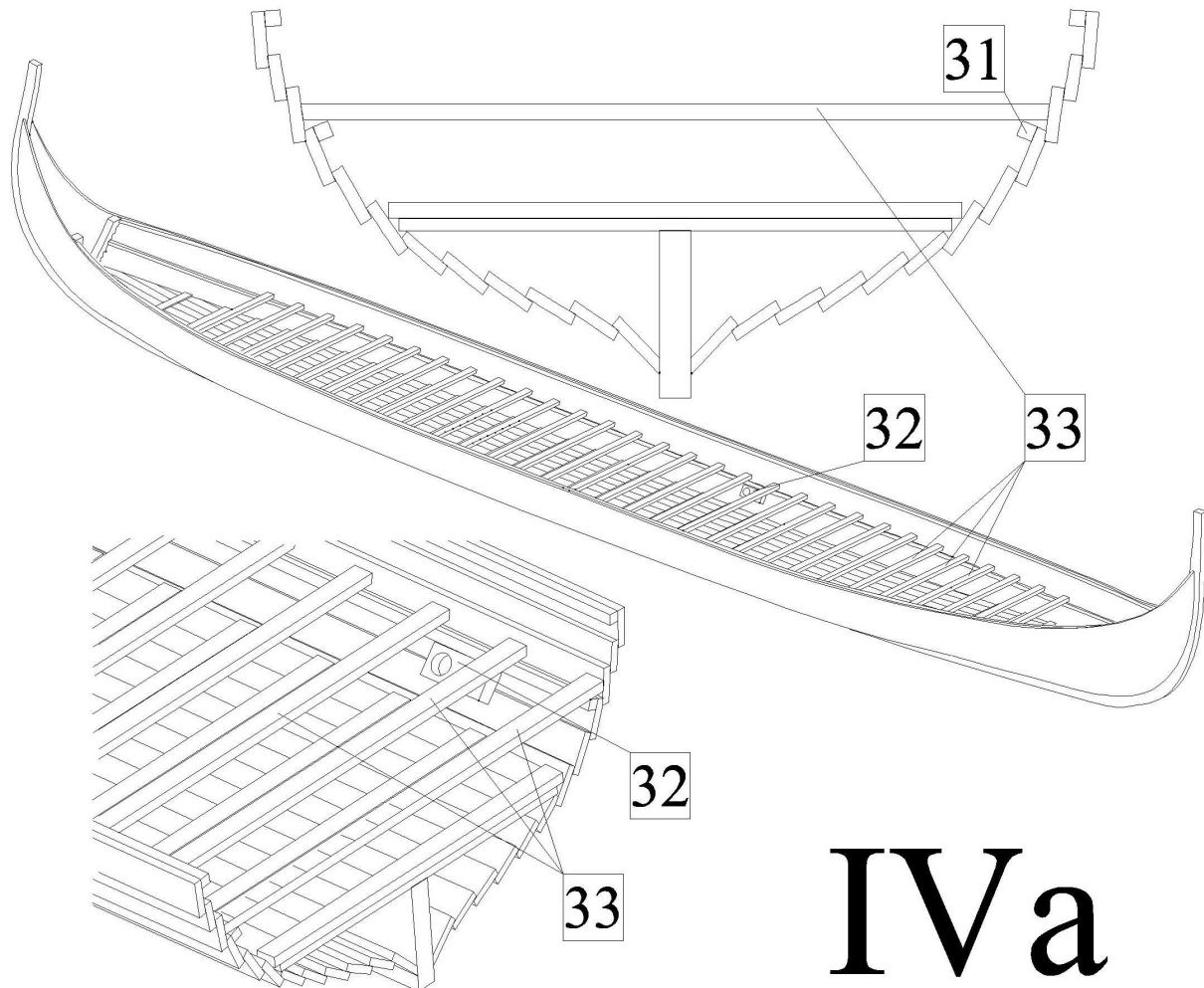

IVa

V) Stand:

a) Glue parts 34-36 to form a stand as shown in diagram Va

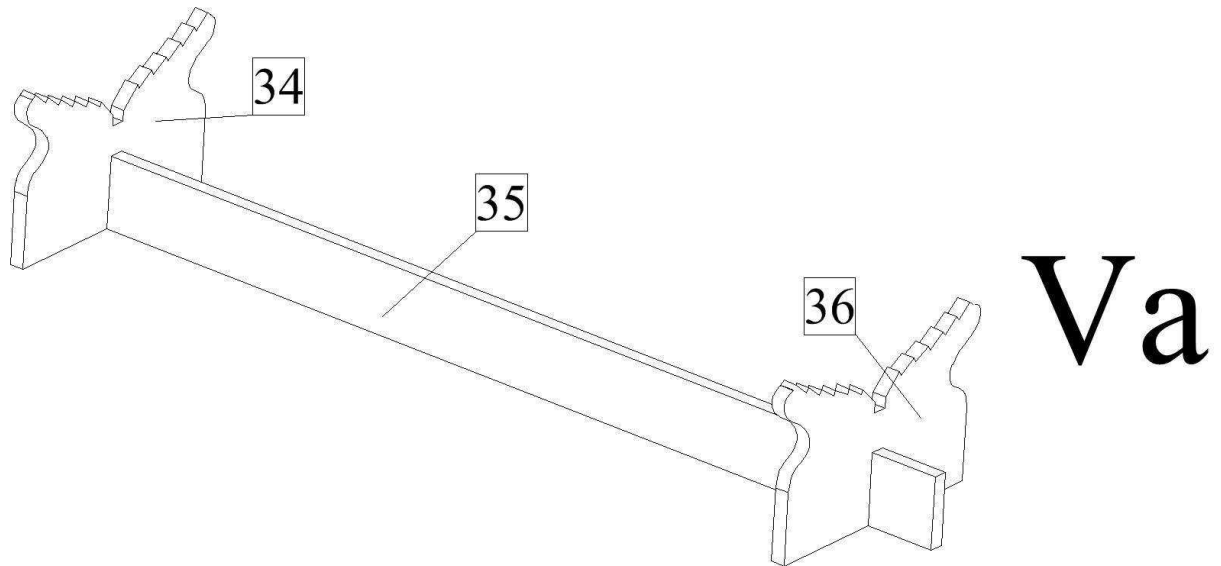

VI) Mast foot:

a) First, glue together parts 37 and 38. Then cut to shape using sandpaper the mast foot as shown in diagram VIa. Then attach the mast foot to the rower's seats. The exact location of the mast foot is displayed at 1:1 scale in the plan 1.

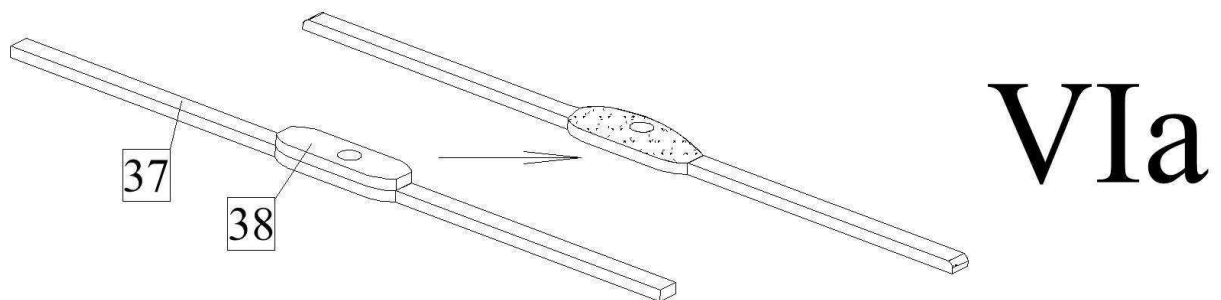

VII) The steering oar:

a) First sandpaper the steering oar 39 into the desired shape, ie the rudder in an oval cross-section and the neck in a circular cross section.

Drill the steering sheet 43 hole with a diameter of 1mm.

Then cut the handle 40 and attach it to the steering oar.

Glue together parts 41

Stick the steering oar to the hull. The exact location of the steering oar is shown at 1:1 scale in the plan 1.

On the ship's side, attach the steering oar washer 42, whose position is also shown at 1:1 scale in the plan 1.

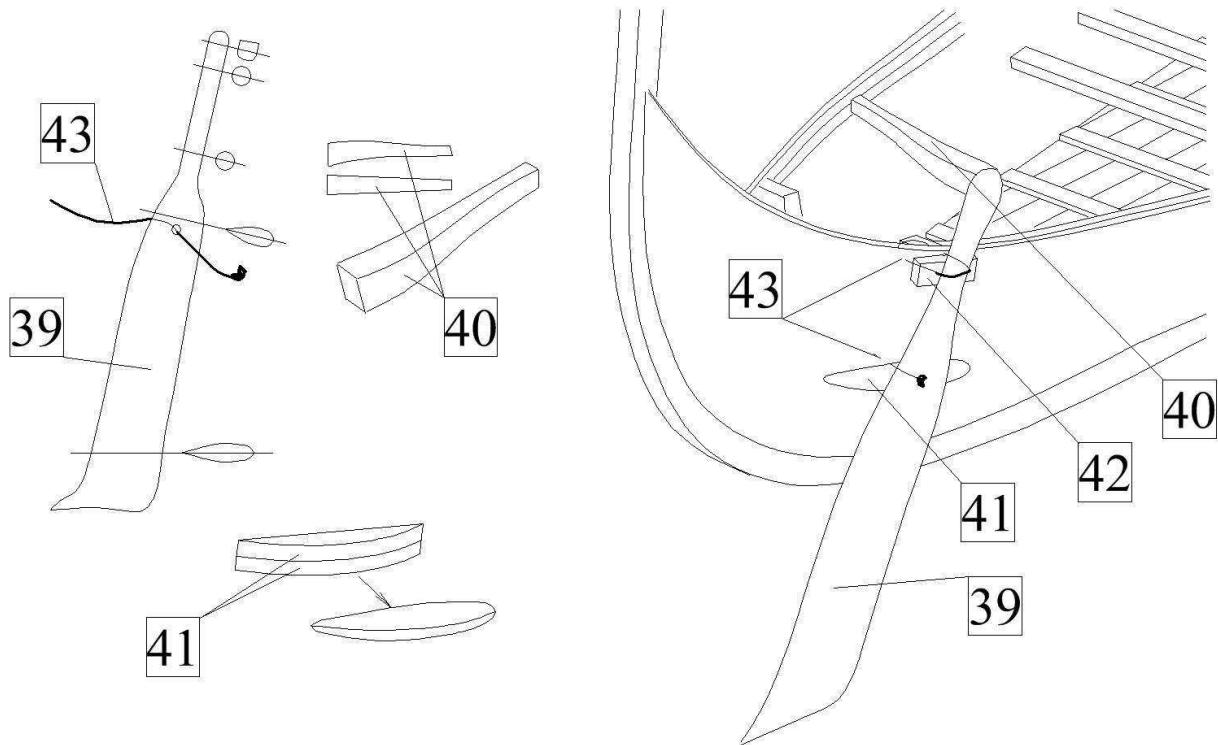

VIIa

VIII) Openings in the hull:

a) In planks 28, drill holes with a diameter of 2mm. In planks 29 drill holes with diameter of 1mm for tethering the shields and shrouds. The location of the holes in the hull is shown at 1:1 scale in the plan 1.

IX) Mast:

a) From the logs with a diameter of 4 mm cut the cone-shaped mast 45. On top of the mast cut collection for tethering ropes and drill a 1mm hole. Then attach the mast to the foot of the mast. The mast is shown at 1:1 scale in the plan 1.

b) Use the rope 43 and by chain pins connect the mast 44 to the hull of the ship and to the stem and stern. Binding procedure of chain ropes is shown in the picture.

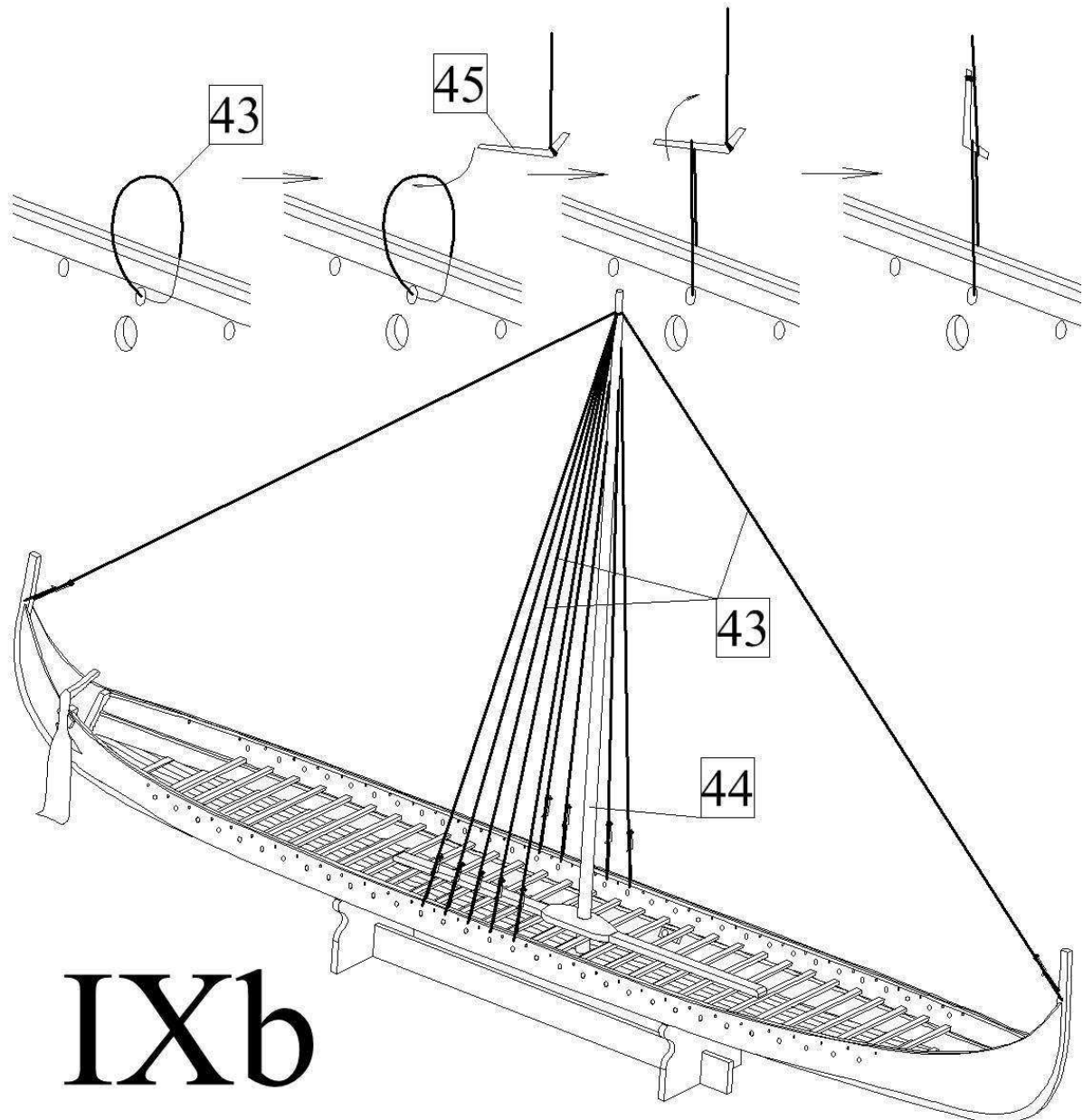

IXb

X) yard:

a) From a 3mm dowel make a yard 46. The yard is displayed at 1:1 scale in the plan 1.

b) Attach the spar rope for pulling and download the yards, then pull the other end of the rope through the hole in the mast with pulleys and 47 consider it to rower's seats, as is shown in the picture. Thereafter attach the yard to the mast. The ends of the yard consider rope used to control yard, and then attach the other end of the rower's seats.

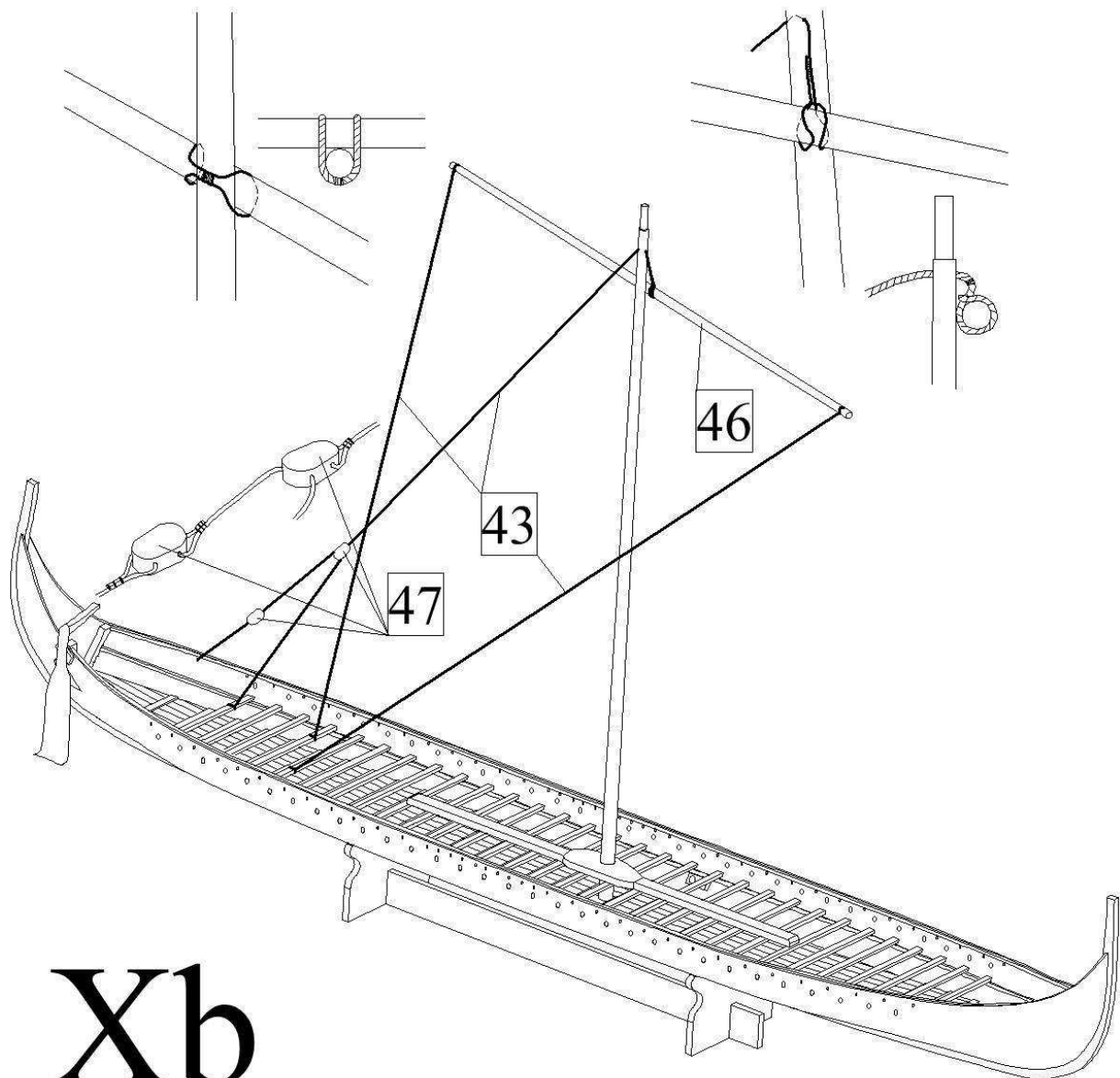

XI) Sail:

a) On the cloth, draw a pencil outline of the sail (Item 48). To the edge of the sail, add 10mm more for the hem. Use a pencil to draw seams to divide the sail into individual segments. Use a sewing machine sews on seams dividing the sheet into individual segments. Then cut out the sail and the edge. Gradually sewn hem of the sheet as shown.

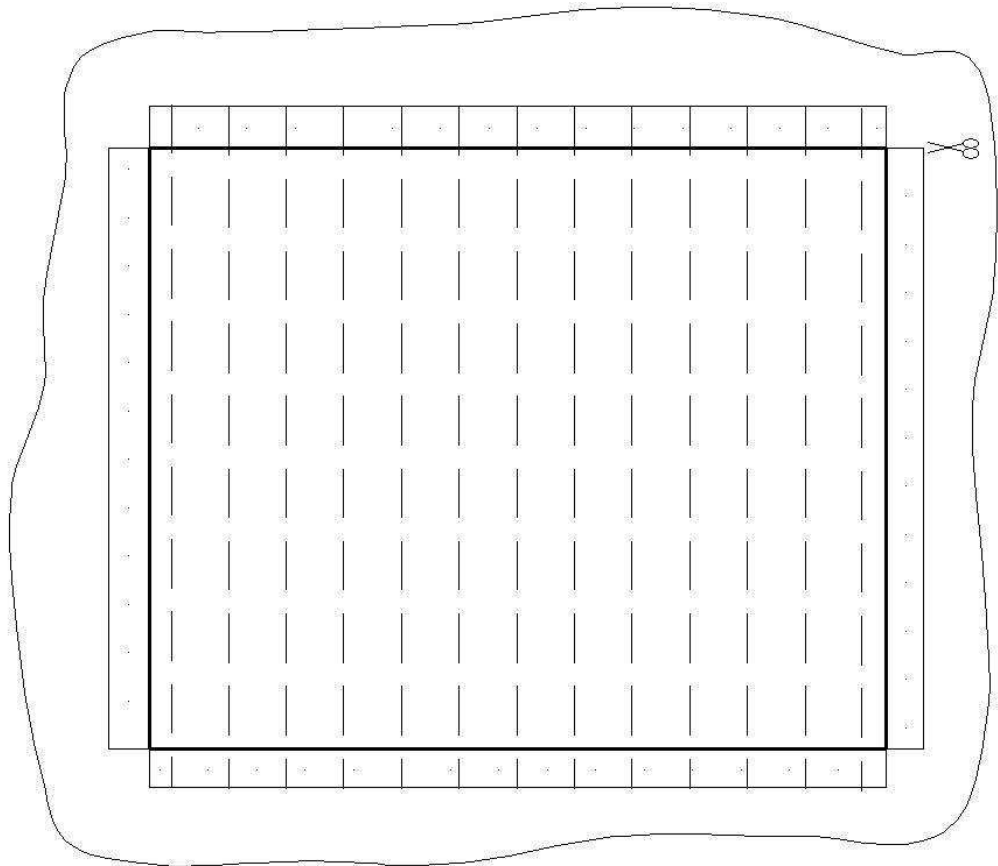

XIa

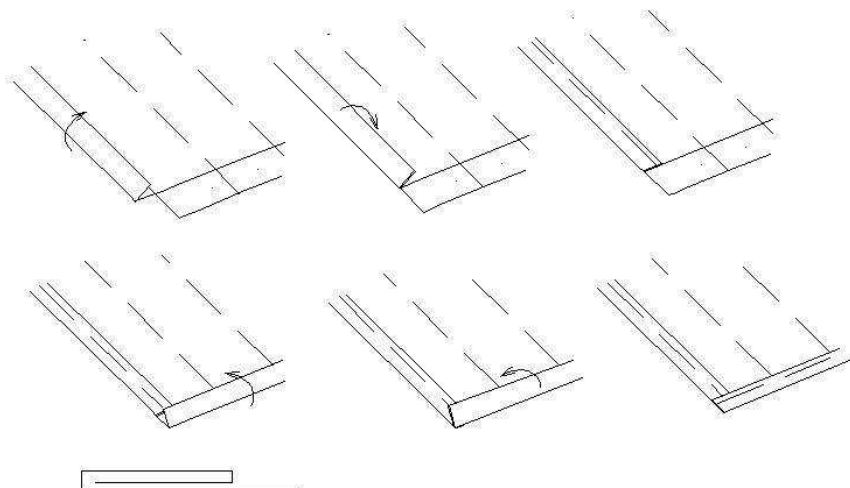

b) Sew rope 49 around the perimeter of the sail. Towards the centre of the sail tie the rope to control the sails 43.

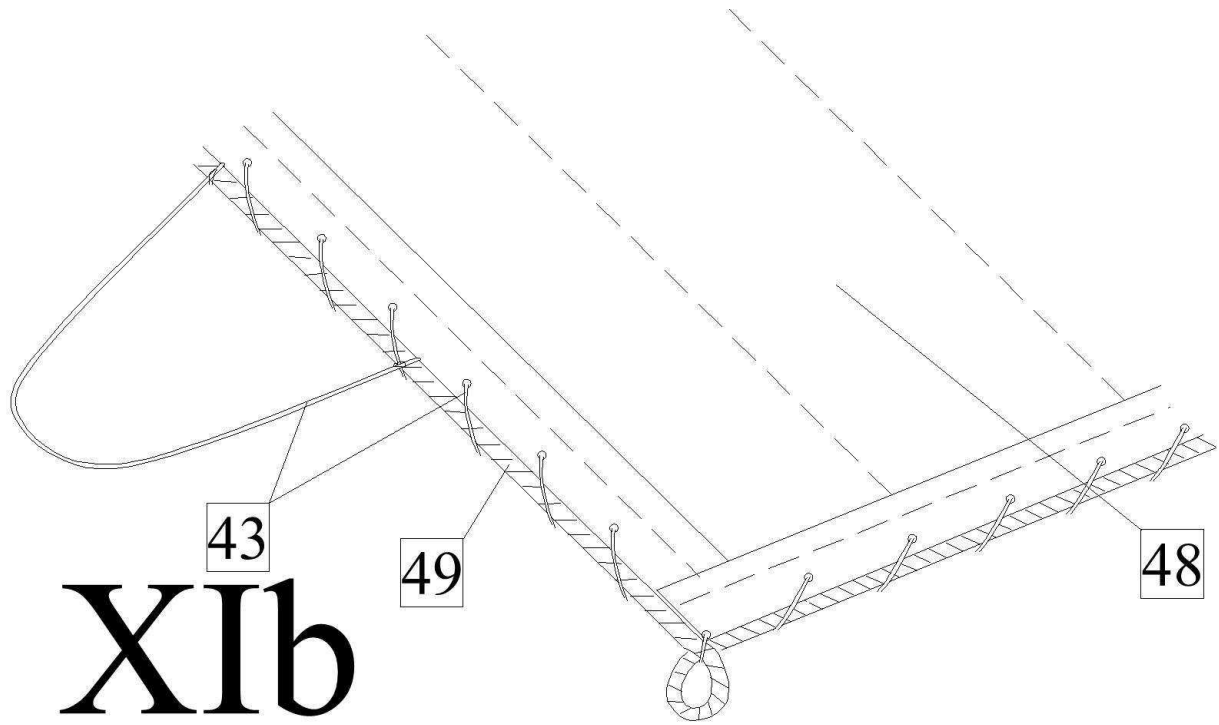

XIb

c) Attach the sail by rope 43 to the yard.

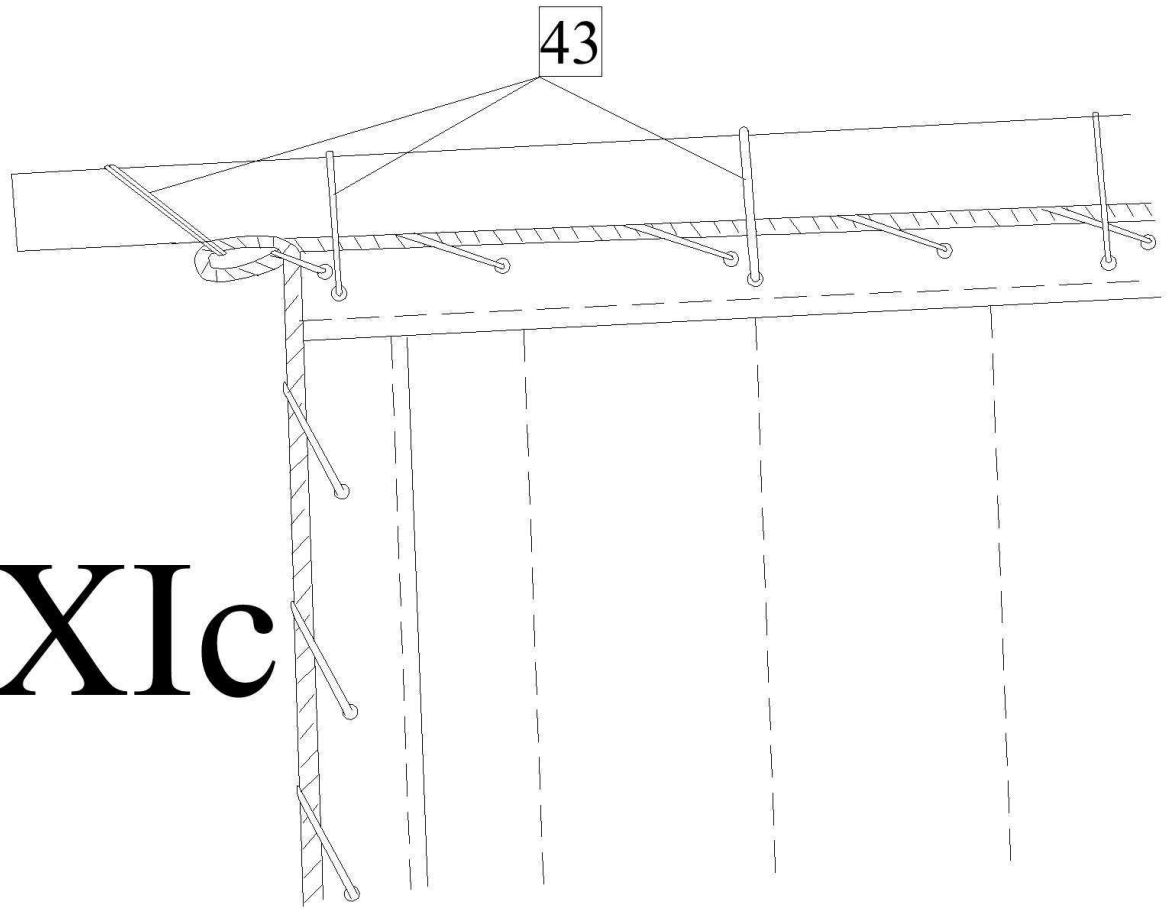

XIc

d) Connect the lower end of the sail to the rower's seats using two ropes, one end of the sail tension by reinforcement bar 50. Tension bar is shown at 1:1 scale in the plan 1. Then attach the others used rope to control the rigging, as is shown in the picture.

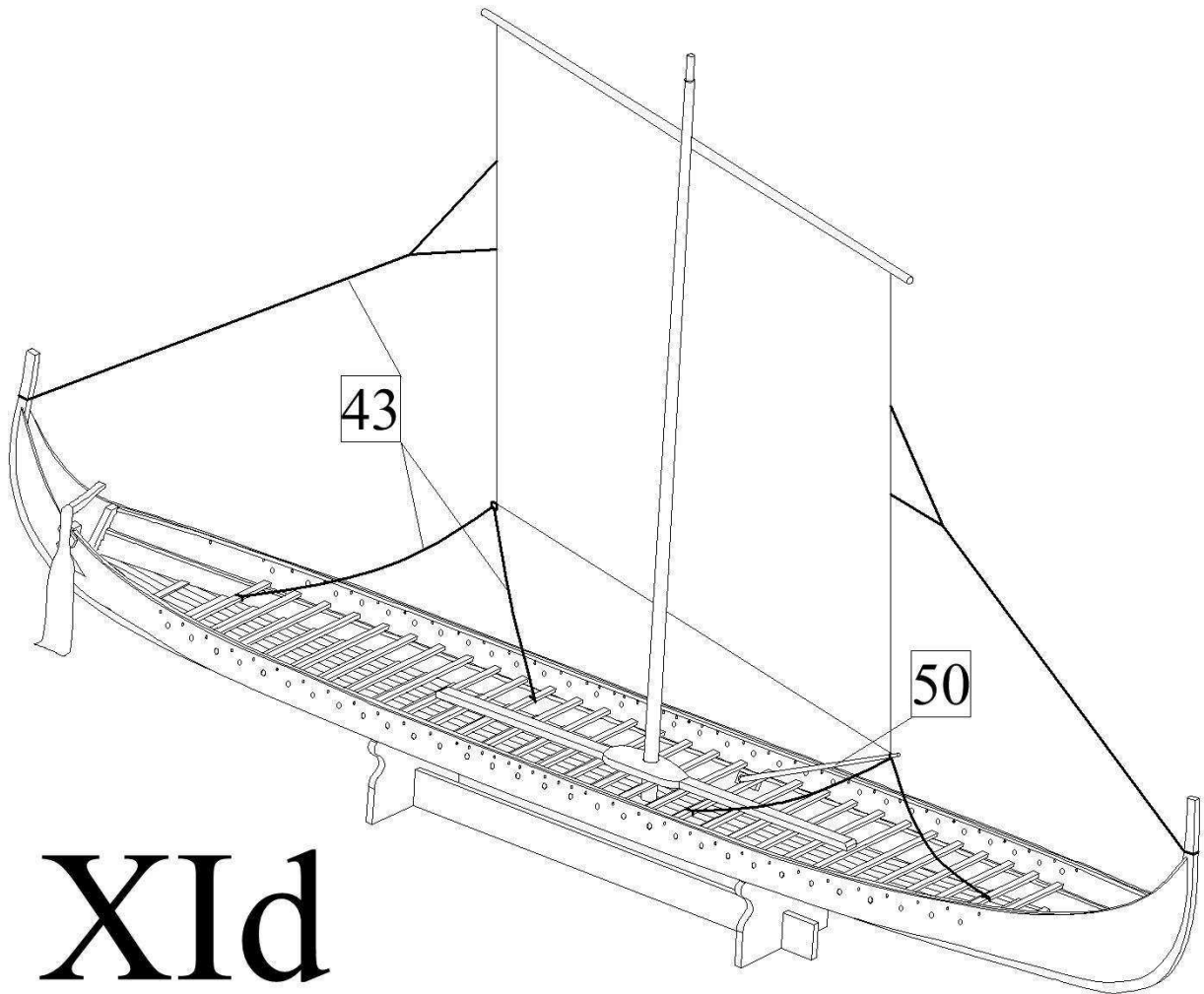

XId

XII) Shields:

a) First make part 53, cut from a 3 mm dowel and shaped by using sandpaper. Then parts 53 are stuck on the front surface of the shield. The handle of the shield 52 can be made from a 4mm piece of 1x1mm with a needle notch. Then attach the handle to the shield.

Tie shields to the body then hull using ropes 43. The shields are displayed on a 1:1 scale plan 1.

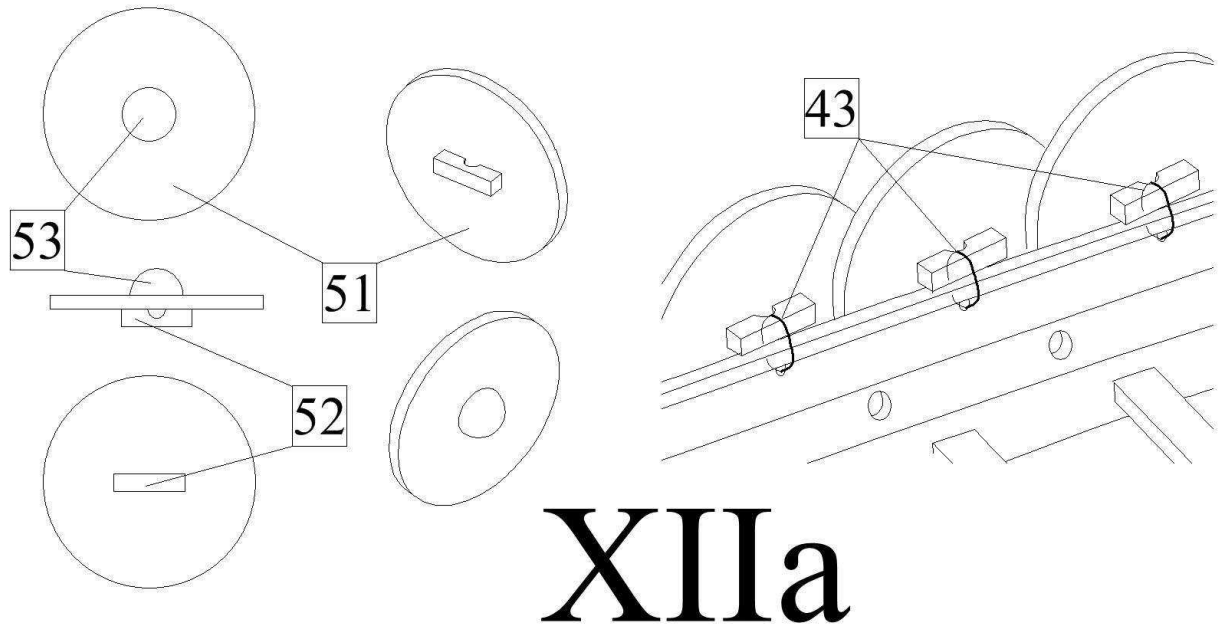

XIII) Oars:

a) Using the 2 mm dowel, make oars 54 and tensioning rods. As a first cut, sandpaper or needle file the handle. At the other end of the oars work it into a semicircular shape.

Then using sandpaper, work the middle of a circular cross section. Finally brand list oars. Oars are shown at 1:1 scale in the plan 1. Production of these would be facilitated by the use of the modellers Mini Lathe.

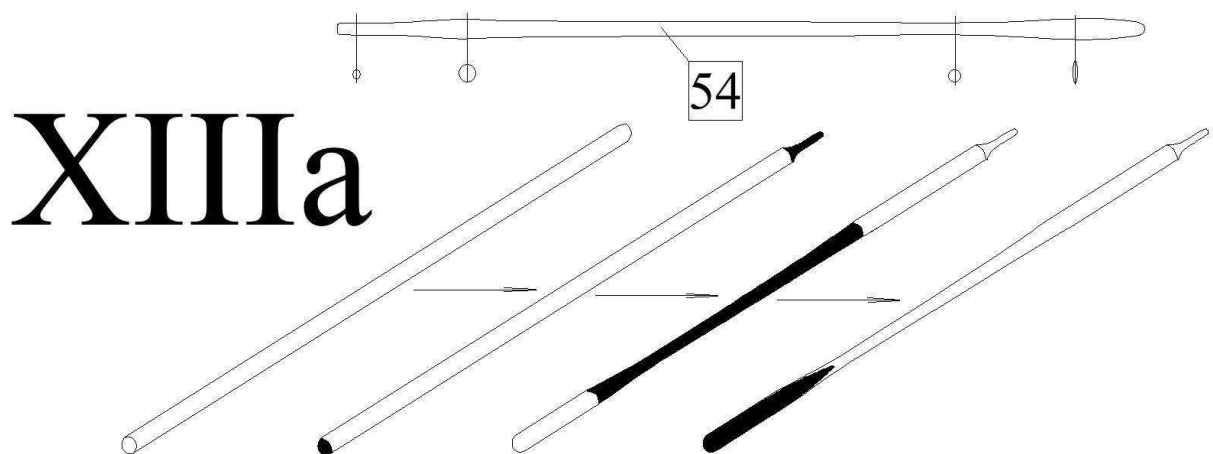

Parts List:

No.	Description	Material	Size	Quantities
0	Keel	wood	2 mm	1 pc
1-13	Ribs	wood	2 mm	1 pc
14	Deck	plywood	0.8 mm	1 pc
15-16	Ribs	wood	2 mm	1 pc
17-28	Plans	plywood	0.8 mm	2 pcs
29	-----			
30	Deck Beams	veneer	0,5mm	1 pc
31	Reinforcement beam	strips	1x1m	6 pcs
32	Plates with holes	wood	2 mm	2 pcs
33	Seats beam	plywood	1x2mm	3 pcs
34-36	Stand	wood	2 mm	1 pc
37-38	Mast foot	wood	2 mm	1 pc
39	Rudder	wood	2 mm	1 pc
40	Rudder	wood	2 mm	1 pc
41	Rudder	wood	2 mm	2 pcs
42	Rudder spar	strips	1x2mm	1 pc
43	Rope	cord	0.4 mm	5 m
44	Mast	dowel	4 mm	1 pc
45	Chain pin	plywood	1.5 mm	12 pcs
46	Yard timber	dowel	3 mm	2 pcs
47	Roller	roller	7 mm	2 pcs
48	Sail	Sail cloth		1 pc
49	Rope	cord	0.8 mm	1 m
50	Rod	dowel	2 mm	12 pcs
51	Shields	plywood	0.8 mm	64 pcs
52	Shields	beam	1x1m	6 pcs
53	Shields	dowel	3 mm	2 pcs
54	Oars	dowel	2 mm	12 pcs.