

  
**PROBOAT™**

# RECALL2®

*18-INCH SELF-RIGHTING DEEP-V BRUSHLESS, RTR*

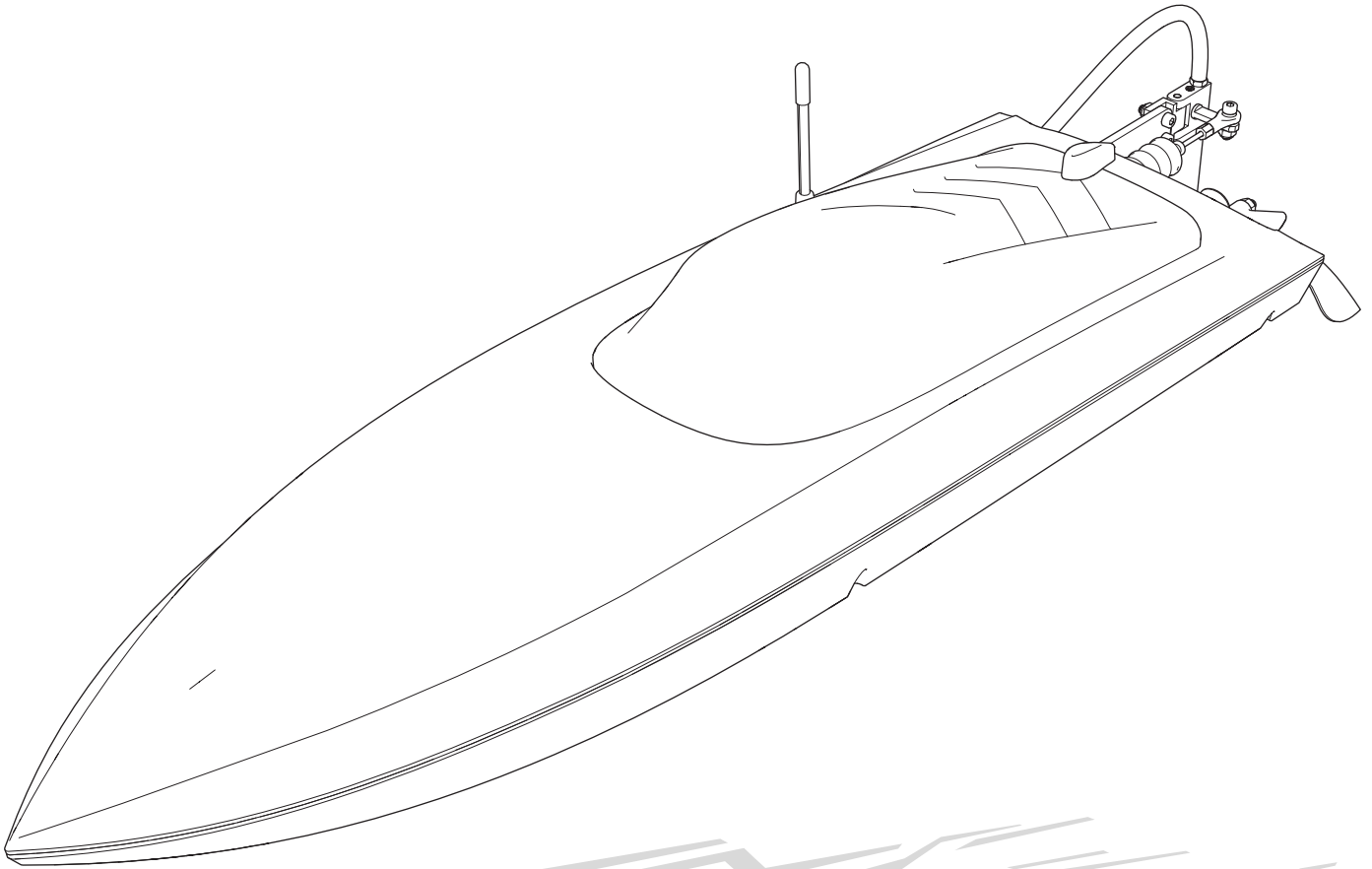

Scan the QR code and select the Manuals and Support quick links from the product page for the most up-to-date manual information.  
Scannen Sie den QR-Code und wählen Sie auf der Produktseite die Quicklinks Handbücher und Unterstützung, um die aktuellsten Informationen zu Handbücher.  
Scannez le code QR et sélectionnez les liens rapides Manuals and Support sur la page du produit pour obtenir les informations les plus récentes sur le manuel.  
Scannerizzare il codice QR e selezionare i Link veloci Manuali e Supporto dalla pagina del prodotto per le informazioni manuali più aggiornate.



PRB08053

Owners Manual • Bedienungsanleitung  
Manuel de l'utilisateur • Manuale dell'utente

593401  
Created: 12/2023

**HORIZON®**  
H O B B Y

## NOTICE

All instructions, warranties and other collateral documents are subject to change at the sole discretion of Horizon Hobby, LLC. For up-to-date product literature, visit [www.horizonhobby.com](http://www.horizonhobby.com) or [www.towerhobbies.com](http://www.towerhobbies.com) and click on the support or resources tab for this product.

## MEANING OF SPECIAL LANGUAGE

The following terms are used throughout the product literature to indicate various levels of potential harm when operating this product:

**WARNING:** Procedures, which if not properly followed, create the probability of property damage, collateral damage, and serious injury OR create a high probability of superficial injury.

**CAUTION:** Procedures, which if not properly followed, create the probability of physical property damage AND a possibility of serious injury.

**NOTICE:** Procedures, which if not properly followed, create a possibility of physical property damage AND little or no possibility of injury.



**WARNING:** Read the ENTIRE instruction manual to become familiar with the features of the product before operating. Failure to operate the product correctly can result in damage to the product, personal property and cause serious injury.

This is a sophisticated hobby product and NOT a toy. It must be operated with caution and common sense and requires some basic mechanical ability. Failure to operate this Product in a safe and responsible manner could result in injury or damage to the product or other property. This product is not intended for use by children without direct adult supervision. Do not use with incompatible components or alter this product in any way outside of the instructions provided by Horizon Hobby, LLC. This manual contains instructions for safety, operation and maintenance. It is essential to read and follow all the instructions and warnings in the manual, prior to assembly, setup or use, in order to operate correctly and avoid damage or serious injury.

**Age Recommendation: Not for children under 14 years. This is not a toy.**

## Safety Precautions and Warnings

As the user of this product, you are solely responsible for operating in a manner that does not endanger yourself and others or result in damage to the product or the property of others.

- When handling and/or transporting your boat, always pick up the boat from the front, keeping all moving parts pointed away from you.
- Always keep a safe distance in all directions around your model to avoid collisions or injury. This model is controlled by a radio signal subject to interference from many sources outside your control. Interference can cause momentary loss of control.
- Always operate your model in open spaces away from full-size vehicles, traffic and people.

- Always carefully follow the directions and warnings for this and any optional support equipment (chargers, rechargeable battery packs, etc.).
- Always keep all chemicals, small parts and anything electrical out of the reach of children.
- Always avoid water exposure to all equipment not specifically designed and protected for this purpose. Moisture causes damage to unprotected electronics.
- Never place any portion of the model in your mouth as it could cause serious injury or even death.
- Never operate your model with low transmitter batteries.

## Water-Resistant Boat with Waterproof Electronics

Your new Horizon Hobby boat has been designed and built with a combination of waterproof and water-resistant components to allow you to operate the product in calm, fresh water conditions.

While the entire boat is highly water-resistant, it is not completely waterproof and your boat should NOT be treated like a submarine. The various electronic components used in the boat, such as the ESC, servo(s) and receiver are waterproof, however, most of the mechanical components are water-resistant and require additional maintenance after use.

Metal parts, including the bearings, pins, screws and nuts, propeller,

rudder, rudder mounts, prop struts, as well as the contacts in the electrical cables, will be susceptible to corrosion if additional maintenance is not performed after running in wet conditions. To maximize the long-term performance of your boat and to keep the warranty intact, the procedures described in the **WET CONDITIONS MAINTENANCE** section must be performed regularly.



**CAUTION:** Failure to exercise caution while using this product and complying with the following precautions could result in product malfunction and/or void the warranty.

## General Precautions

- Read the **Wet Conditions Maintenance** procedures and make sure that you have all the tools you will need to properly maintain your boat.
- Not all batteries can be used in wet conditions. Consult the battery manufacturer before use. Caution should be taken when using Li-Po batteries in wet conditions.
- Most transmitters are not water-resistant. Consult your transmitter's manual or the manufacturer before operation.
- Never operate your transmitter or boat when lightning is present.
- Salt water is very conductive and highly corrosive. If you choose to run your boat in salt water, immediately rinse the boat in fresh water after each use. Operating your boat in salt water is at the sole discretion of the modeler.+

## Charging Warnings

 **WARNING:** Failure to exercise caution while using this product and comply with the following warnings could result in product malfunction, electrical issues, excessive heat, FIRE, and ultimately injury and property damage.

- **NEVER LEAVE CHARGING BATTERIES UNATTENDED.**
- **NEVER CHARGE BATTERIES OVERNIGHT.**
- Never attempt to charge dead, damaged or wet battery packs.
- Never attempt to charge a battery pack containing different types of batteries.
- Never allow children under 14 years of age to charge battery packs.
- Never charge batteries in extremely hot or cold places or place in direct sunlight.
- Never charge a battery if the cable has been pinched or shorted.
- Never connect the charger if the power cable has been pinched or shorted.
- Never attempt to dismantle the charger or use a damaged charger.
- Always use only rechargeable batteries designed for use with this type of charger.
- Always inspect the battery before charging.
- Always keep the battery away from any material that could be affected by heat.
- Always monitor the charging area and have a fire extinguisher available at all times.

## Wet Conditions Maintenance

- Drain any water that has collected in the hull by removing the drain plug or canopy and tilting the boat in the appropriate direction to drain the water.

 **CAUTION:** Always keep hands, fingers, tools and any loose or hanging objects away from rotating parts.

- Remove the battery pack(s) and dry the contacts. If you have an air compressor or a can of compressed air, blow out any water that may be inside the recessed connector housings.
- Remove all moving parts. Dry and lubricate parts after every 30 minutes of operation or if the boat becomes submerged.

**NOTICE:** Never use a pressure washer to clean your boat.

- Use an air compressor or a can of compressed air to dry the boat and help remove any water that may have gotten into small crevices or corners.
- Spray the bearings, fasteners and other metal parts with a water-displacing light oil or lubricant.
- Let the boat air dry before you store it. Water (and oil) may continue to drip for a few hours.

- Always end the charging process if the battery becomes hot to the touch or starts to change form (swell) during the charge process.
- Always connect the positive leads (+) and negative leads (-) correctly.
- Always disconnect the battery after charging, and let the charger cool between charges.
- Always charge in a well-ventilated area.
- Always terminate all processes and contact Horizon Hobby if the product malfunctions.
- Charge only rechargeable batteries. Charging non-rechargeable batteries may cause the batteries to burst, resulting in injury to persons and/or damage to property.
- The USB outlet shall be installed near the equipment and shall be easily accessible.

 **CAUTION:** Always ensure the battery you are charging meets the specifications of this charger. Not doing so can result in excessive heat and other related product malfunctions, which can lead to user injury or property damage.

 **CAUTION:** If at any time during the charging process the battery pack becomes hot or begins to puff, disconnect the battery immediately and discontinue the charge process as batteries can cause fire, collateral damage and injuries.

## Box Contents

- Pro Boat® Recoil 2® 18-Inch Self-Righting Deep-V RTR (PRB08053)
- Spektrum™ Firma 30A Brushless Marine ESC 2-3S (SPMXME1030)
- Spektrum™ SR315 DSMR/SLT Dual Protocol 3ch Receiver (SPMSR315)
- Horizon® 13g Servo Metal Gear Waterproof (HRZ00007)
- Spektrum™ Firma 2931 2950Kv 8-Pole Outrunner Marine Motor (SPMX-1029)
- Spektrum™ S120 USB-C Smart Charger, 1 x 20W (SPMXC1020)
- Spektrum™ 1300mAh 3S 11.1V Smart LiPo Battery 30C IC3 (SPMX13003S30M)
- Spektrum™ SLT3 Multi-Programmed Standard Transmitter (SPMSLT320)
- 4 AA Alkaline Transmitter Batteries

## Recommended Tools and Materials

- Paper towel
- Rubbing alcohol
- Nut driver: 5.5mm, 6mm
- Hex wrench: 1.5mm, 2mm
- Clear tape (DYNM0102)
- Dynamite® Marine Grease and Gun (DYNE4200)
- Clean towels

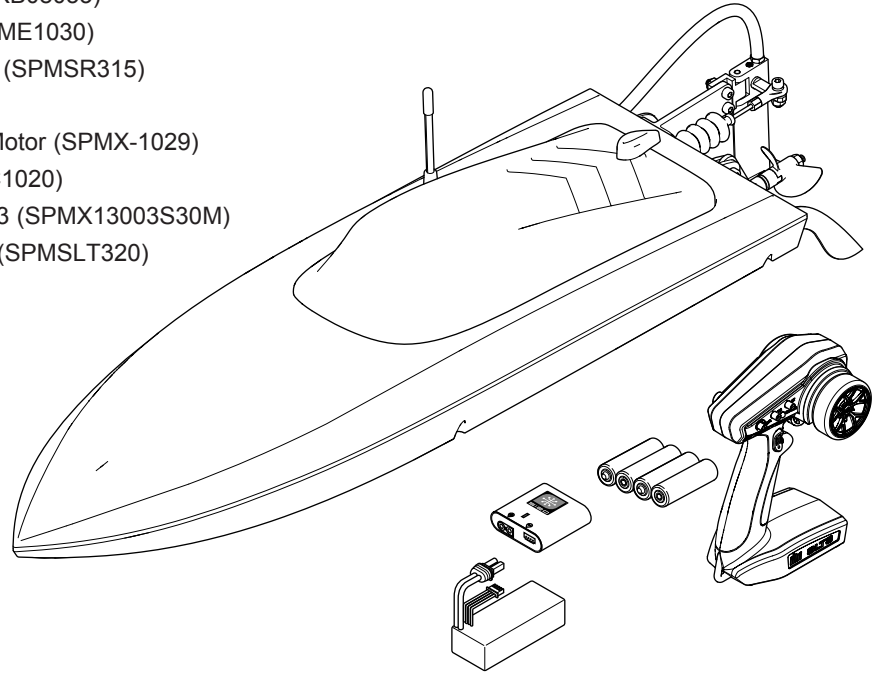

## Specifications

<b>Length</b>	17.89 in. (454 mm)
<b>Beam</b>	4.8 in. (123 mm)
<b>Hull Height</b>	3.3 in. (85 mm)
<b>Hull Material</b>	ABS

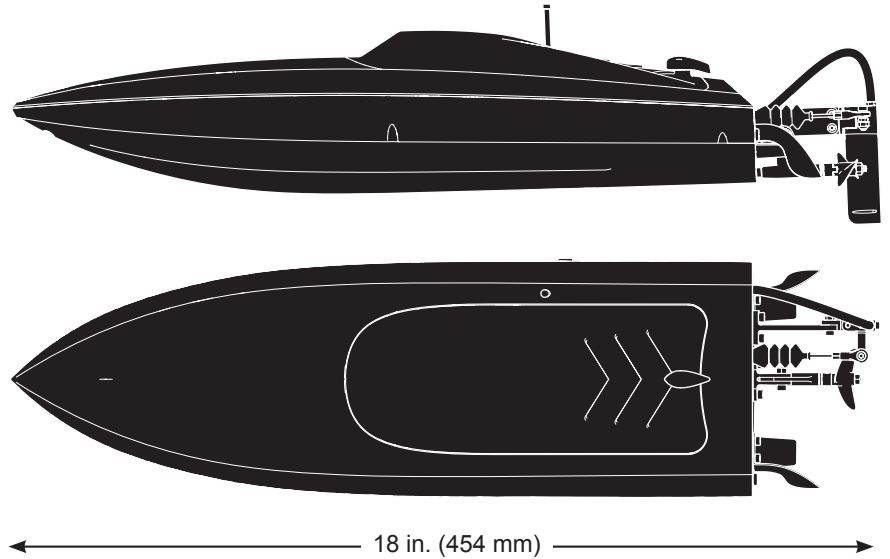
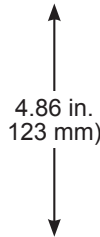
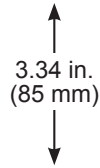

## Table of Contents

Safety Precautions and Warnings.....	2	Low Voltage Cutoff (LVC) .....	7
Water-Resistant Boat with Waterproof Electronics .....	2	Boating Tips .....	7
General Precautions.....	3	When You Are Finished .....	8
Wet Conditions Maintenance .....	3	Binding.....	8
Charging Warnings.....	3	Maintenance .....	8
Box Contents.....	4	Replacement Parts.....	10
Recommended Tools and Materials .....	4	Optional Parts.....	10
Specifications .....	4	Recommended Parts.....	10
Installing the Transmitter Batteries.....	5	Troubleshooting Guide.....	11
Transmitter Functions.....	5	2-Year Limited Warranty .....	12
Antenna Tube Installation.....	6	Warranty and Service Contact Information .....	13
Battery Pack Installation.....	6	FCC Information .....	13
Range Check.....	6	IC Information.....	13
Self-Righting .....	6	Compliance Information for the European Union.....	13
Getting Started .....	7	Exploded View.....	51

## Installing the Transmitter Batteries

This transmitter requires 4 AA batteries (included).

1. Remove the battery cover from the transmitter.
2. Install the batteries as shown.
3. Install the battery cover.

**CAUTION:** NEVER remove the transmitter batteries while the model is powered on. Loss of model control, damage, or injury may occur.

**CAUTION:** If using rechargeable batteries, charge only rechargeable batteries. Charging non-rechargeable batteries may cause the batteries to burst, resulting in injury to persons and/or damage to property.

**CAUTION:** Risk of explosion if battery is replaced by an incorrect type. Dispose of used batteries according to national regulations.

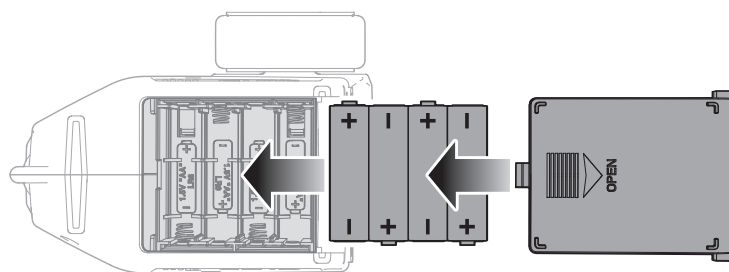

## Transmitter Functions

### SPECIFICATIONS

**Power Supply:** 4 AA Batteries

**Operating Frequency:** 2.4GHz

**Transmit Power:** <100mw

**Control Protocol:** SLT

**Control:** Proportional Steering and Throttle/Brake with Trim Knobs

**Auxiliary Functions:** 3 Position Throttle Limit Switch, Steering Rate Knob to Change Steering Travel On-the-Fly, Programmable Servo Travel for Steering and Throttle/Brake

#### A. Throttle Trim

Adjusts the throttle neutral point

#### B. Steering Trim

Adjusts the steering center point. Normally, the steering trim is adjusted until the vehicle tracks straight.

#### C. LED

- Solid red lights: Indicates the power is ON and adequate battery power
- Flashing red lights: Indicates the battery voltage is critically low. Replace batteries

#### D. Steering Wheel

#### E. Throttle/Brake

#### F. Steering Rate

On-The-Fly knob for travel adjustment on the steering

#### G. Rocker Switch

- **A:** Self -Righting: Hold down to self right. Release when the boat is upright.
- **B:** Not used

#### H. Throttle Limit

Limits throttle output to 50/75/100%

Select 50% or 75% for less experienced drivers or when you are driving the vehicle in a small area.

#### I. Throttle (TH) Servo Reversing

Move the switch to reverse the throttle channel

#### J. Steering (ST) Servo Reversing

Move the switch to reverse the steering channel

#### K. Power Button

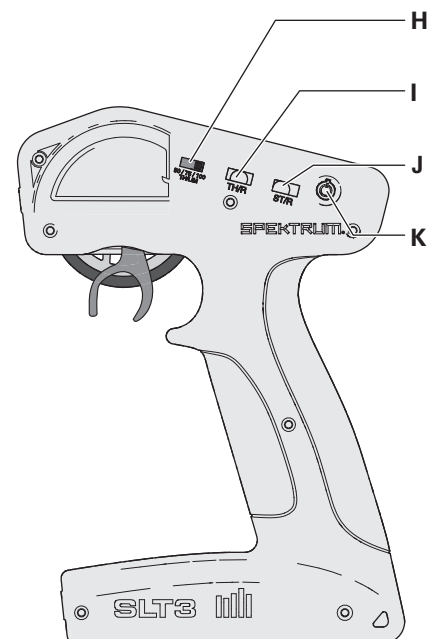
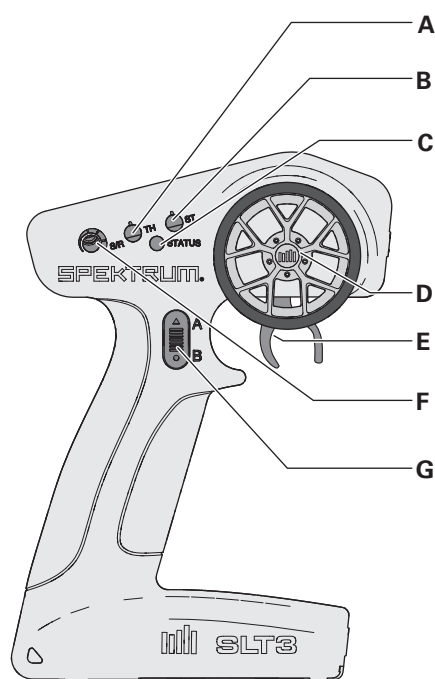

## Antenna Tube Installation

Install the receiver antenna in the tube as shown. Do not bend end of antenna over antenna tube and place cap over it. The antenna does not have to be outside of the tube to operate properly.

Keep the end of the antenna above the boat's waterline to get the best transmitter reception. Apply clear tape (DYNAM0102), if desired.

**NOTICE:** Do not cut or kink the receiver antenna or damage may result.



## Battery Pack Installation

1. Turn canopy lock 90°
2. Carefully lift the canopy from the hull.
3. Install the battery in the battery tray.
4. Connect the battery to the ESC power connectors.
5. Before placing your boat in the water, secure the canopy on the hull. Apply clear tape (DYNAM0102), if desired.

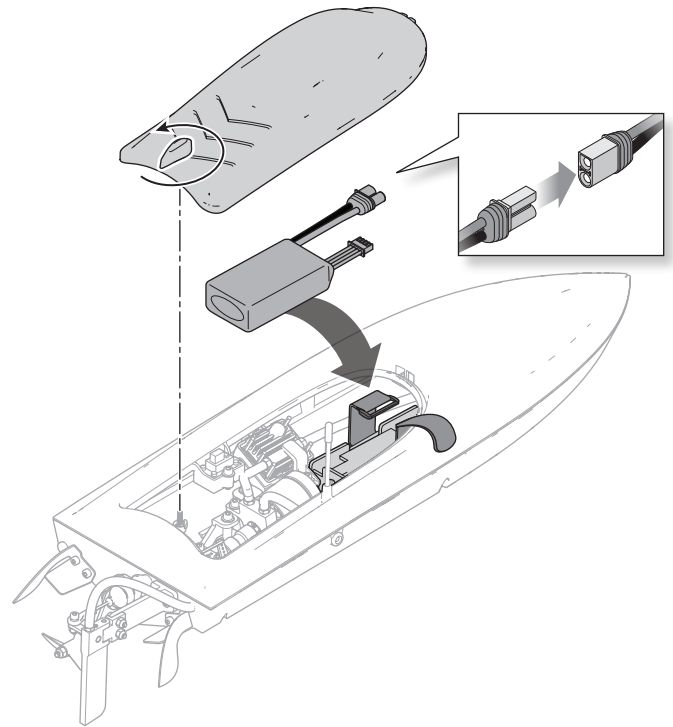

## Range Check

**IMPORTANT:** Perform a range check at the beginning of each boating session, after repair or after installation of a new battery. Ensure that the battery is fully charged.

1. With the radio system powered on and connected, walk away from your boat 90 feet (32 m).
2. Have an assistant remain with the boat to check for proper control movement of the steering mechanism in response to your transmitter input.
3. If everything appears to be operating correctly, prepare to operate the boat in the water.

## Self-Righting

The Recoil 2 features an auto self-righting feature. This feature is most effective at or above half power.

To engage the self-righting feature:

1. Press and hold the **A** button on your transmitter, and the boat will self-right.
2. Once the boat has flipped upright, release the **A** button to resume normal operation.  
If you are below half power, use the throttle and brake normally to self-right the boat. Pulse the throttle and brake alternatively, and the boat will self-right.

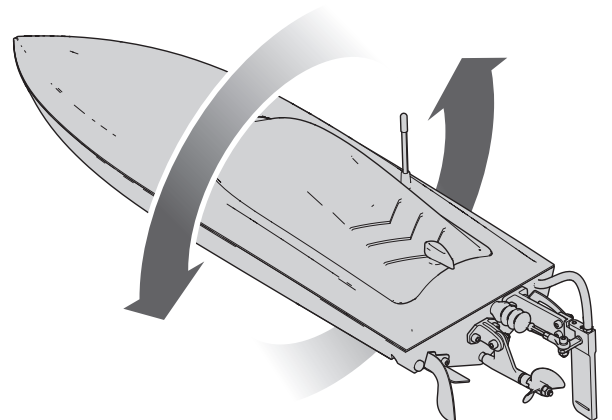



## Getting Started

1. Power ON the transmitter.
2. Connect the battery to the IC3 connectors on the receiver/ESC.
3. Power on the receiver/ESC.
4. Test the transmitter's control of the boat with the boat on the display stand.

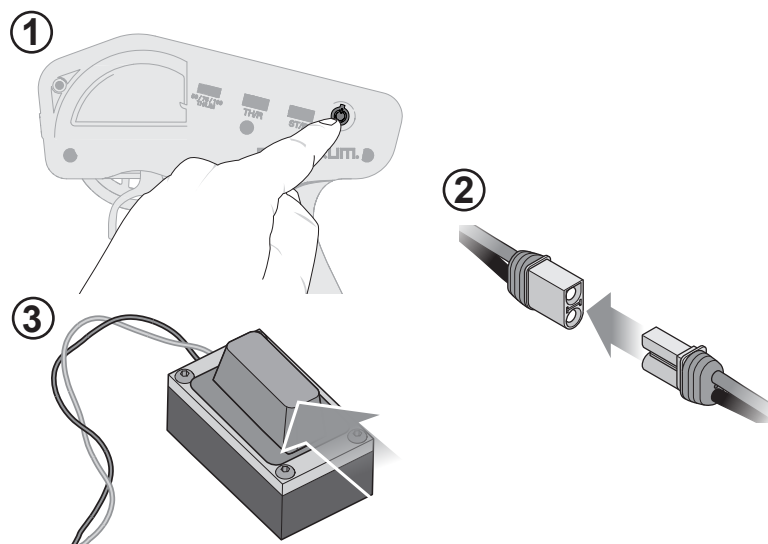

## Low Voltage Cutoff (LVC)

The factory default setting for the LVC in the ESC included with your boat is set at 3.2V per cell. Discharging a Li-Po battery below 3V per cell may damage your battery. The included ESC protects the boat battery from over-discharge using Low Voltage Cutoff (LVC). Before the battery charge decreases too much, LVC removes power supplied to the motor.

The boat drastically slows or stops completely once LVC is activated. Releasing the throttle and reapplying it will provide a limited amount of power to safely return the boat to shore. Repeated use after LVC is activated will damage the batteries.

Once LVC has been activated, the ESC status light will flash red continuously indicating that the ESC is in LVC mode.

**NOTICE:** Repeated operation to LVC will damage the battery.

LVC can activate prematurely if you use (1) a low C-rated battery or (2) an old, worn, and/or weak battery.

The average run time using the recommended battery (SPMX13003S30M) is approximately 5–7 minutes, depending on throttle usage. Limited run time may indicate worn or weak batteries.

**TIP:** If you've installed a freshly charged battery and LVC activates within the first minute of operation, replace your worn or weak batteries with the recommended batteries.

**TIP:** Monitor your boat battery's voltage before and after boating by using a Li-Po Cell Voltage Checker (SPMXBC100, sold separately). Disconnect and remove the Li-Po battery from the boat after use to prevent trickle discharge. Charge your Li-Po battery to half capacity before storage. During storage, make sure the battery charge does not fall below 3V per cell. LVC does not prevent the battery from over-discharge during storage.

## Boating Tips

During the first run, we recommend calm wind and water conditions to ensure that the boat is properly set up. Maximum speeds of 35 MPH/+ can be achieved once you have set up the boat for your specific conditions. Top speed will also be determined by the battery's ability to efficiently deliver power to the motor via the ESC.

1. Consult local laws and ordinances before choosing a location to pilot your boat.
2. Carefully place the boat in the water.
3. Operate the boat at slow speeds near the shoreline. Avoid objects in the water at all times. When the boat is moving forward, ensure water flows out of the coolant outlet.
4. Once you are comfortable operating the boat at slow speeds, it is safe to operate the boat farther from the shore at higher speeds.
5. Bring the boat back to shore when the motor starts to pulse.

**NOTICE:** Never operate your boat in less than 12 inches (30.5 cm) of water.

**CAUTION:** Never attempt to retrieve a downed boat by swimming. If you need to retrieve your boat from the water, use fishing equipment or another boat.

**NOTICE:** When running at full speed in choppy water, the propeller may exit and re-enter the water repeatedly and very quickly, subjecting the propeller and drive shaft to some stress. Frequent stress may damage the propeller and drive shaft.

In rough water and windy conditions, consider:

- mounting the batteries further forward for added stability
- adjusting the struts downward to prevent the boat from overturning

### Avoid boating near:

- watercraft
- people (swimming areas, fishing areas)
- stationary objects
- waves and wakes
- rapidly moving water
- wildlife
- floating debris
- overhanging trees
- vegetation

## When You Are Finished

1. Power OFF the receiver.
2. Power OFF the transmitter.
3. Disconnect and remove the battery from the boat.
 

**TIP:** Always remove the canopy before storage or moisture may allow mold and mildew to grow in the boat.
4. Drain water from inside the hull using the drain plug.
5. Fully dry the inside and outside of the boat, including the water cooling lines and motor cooling block. Carefully dry all battery, motor and receiver connectors by removing one at a time and reinstalling.
6. Remove the hatch before storing your boat.
7. Repair any damage or wear to the boat.
8. Lubricate the flex shaft using Pro Boat® Marine Grease (DYNE4200 or DYNE4201).
9. Note the lessons learned from the trimming of your boat, including water and wind conditions.

**NOTICE:** When you are finished boating, never leave the boat in direct sunlight or in a hot, enclosed area such as a car. Doing so can damage the boat.

**NOTICE:** Using a larger propeller, or one with more pitch than the one included, may damage the electronics and battery packs.v

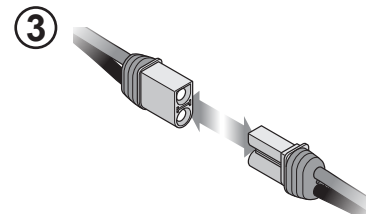
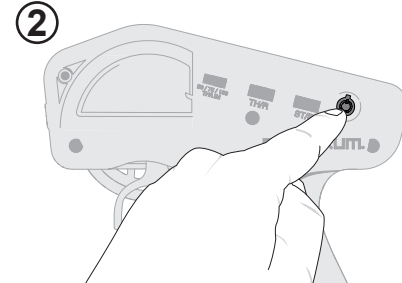
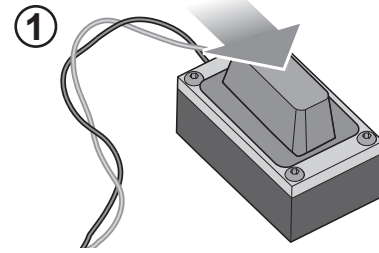

## Binding

Binding is the process of electronically linking the transmitter to the receiver. The included transmitter and receiver are bound at the factory. If rebinding is necessary, follow these steps:

**NOTICE:** Always keep all body parts, loose clothing and other items away from the propellers.

**IMPORTANT:** If using a different receiver/radio system, follow the binding instructions included with that receiver.

1. Power ON the receiver, press the bind button three times quickly (within 1.5 seconds). The orange LED will begin to flash with a pause.
2. Set the trims and control positions at the desired failsafe settings, and power ON the SLT3 transmitter.
3. When the orange LED on the SLT3 transmitter remains lit, it is connected to SR315 receiver.

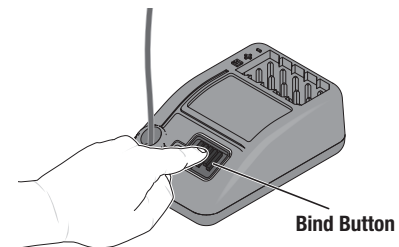

## Maintenance

### Propeller Service

1. Use a 5.5mm nut driver to loosen the nut (A) from the driveshaft (B).
2. Remove the nut and propeller (C) from the driveshaft.
3. Inspect the propeller for any damage or wear and replace as necessary.
4. Assemble in reverse order. Correctly align the propeller with the drive dog on the driveshaft.

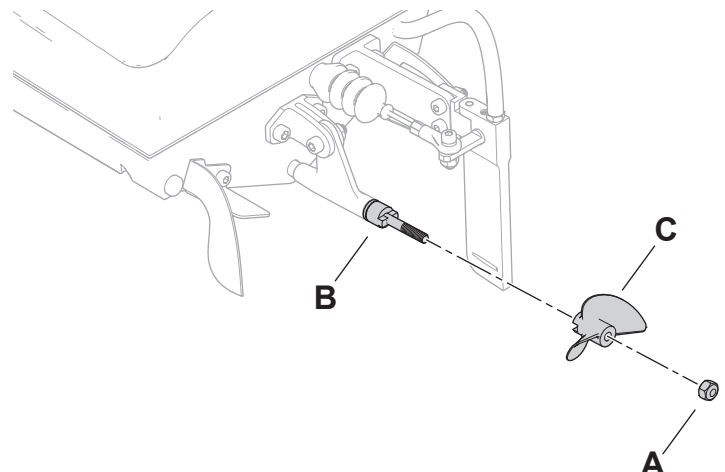



## Water Cooling System

If water does not stream out of the right-side water outlet while the boat is moving forward, immediately stop the boat and clean the obstruction from the water-cooling system.

1. Disassemble and clean the water cooling system to remove blockage and prevent overheating.
2. Replace any damaged parts.

**IMPORTANT:** Ensure that the water cooling exit ports are securely attached to the outside of the hull. Failure to inspect this can result in excess water entering the hull.

**CAUTION:** Running a battery with less than 11.1V will not provide enough momentum to engage the water-cooling system and will cause damage to the electronics due to excessive heat.

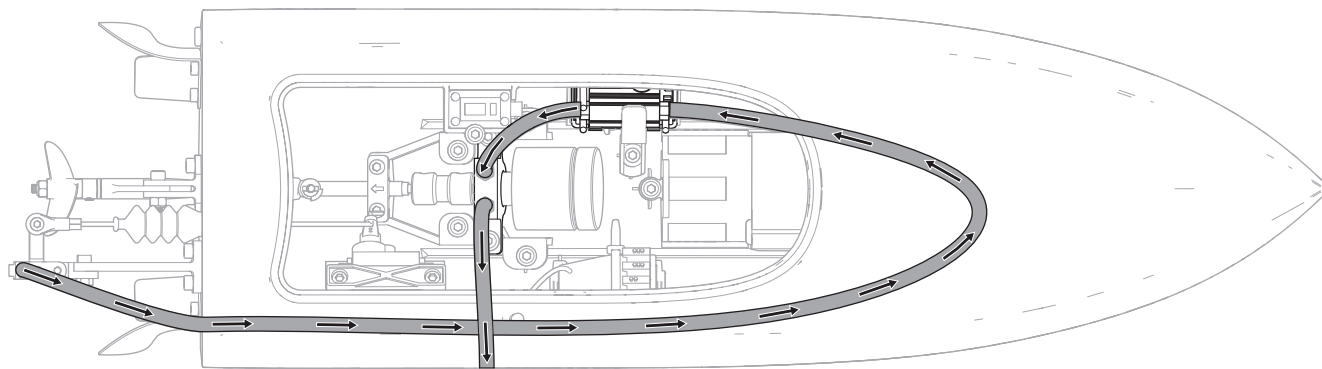

## Flex Shaft Maintenance

Lubricating the flex shaft is vital to the life of the drivetrain. This process removes any water from the system, preventing corrosion which leads to higher friction, lower performance, and a shorter product lifespan. The lubricant also acts as a water seal, keeping water from entering the hull through the stuffing tube.

Perform flex shaft maintenance after every boating session.

1. Power OFF the boat, and remove the battery.
2. Use a 2mm hex driver to loosen the set screw on the flex shaft coupler.
3. Slide the flex shaft toward the rear of the boat.
4. Using a towel or paper towel, remove old lubricant and material.
5. Apply a liberal amount of lubrication to the flex shaft and spread it around the entire shaft. Ensure enough lubrication is on the shaft to prevent any dry areas.

**NOTICE:** When lubricating the flex shaft, do not lubricate the first 20mm of the flex shaft. If grease gets into the motor coupler, it may cause the flex shaft to slip inside of the coupler, thereby damaging it and requiring replacement.

6. Slide the flex shaft into the prop strut and stuffing tube. Rotate it to spread the grease on the inside of the stuffing tube, ensuring that there is a 1–2mm gap between the propeller strut and the drive dog. This will allow space for the shaft as it shrinks under load. Without space, the drive dog could damage the aluminum propeller strut.

**NOTICE:** Ensure the flex shaft is installed correctly. Installing the flex shaft incorrectly may result in irreparable damage to the boat.

7. Tighten the set screw using a 2mm allen driver.

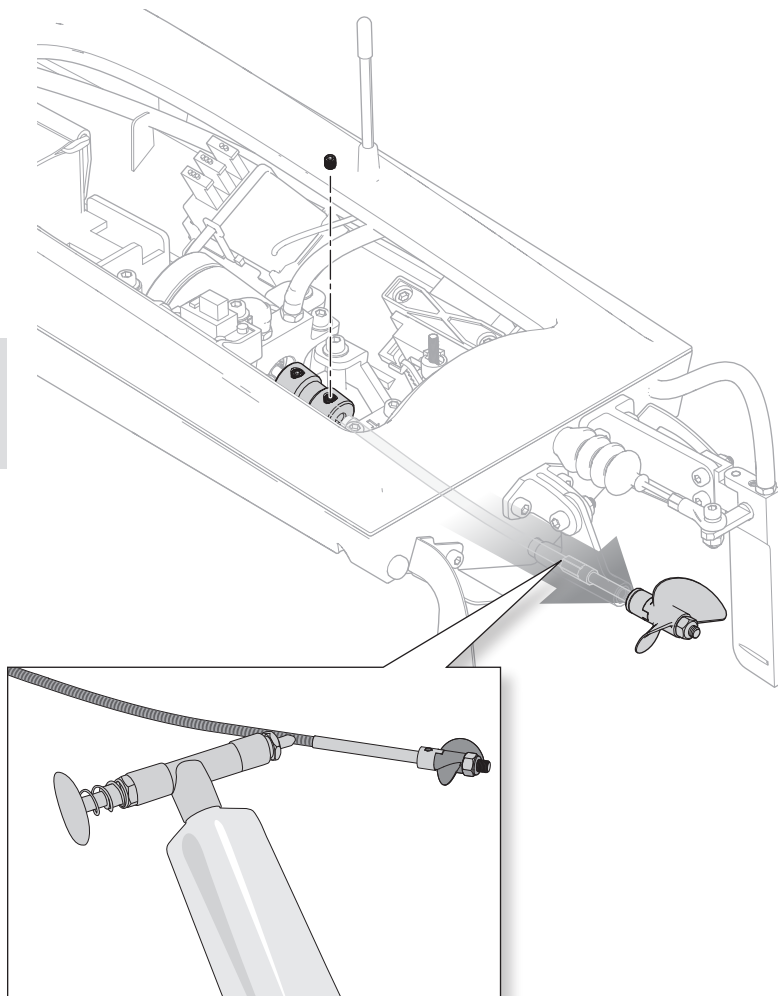

## Replacement Parts

Part #	Description
PRB-1150	Hull and Canopy, Shreddy: Recoil 18
PRB-1396	Hull and Canopy, Heatwave: Recoil 18
PRB-1151	Hull Mounts: Recoil 18
PRB-1152	Motor Mount, Water Block: Recoil 18
PRB-1153	Water Cooling Line 4mm ID, 36"
PRB-1154	Rudder Set: Recoil 18
PRB-1155	Rudder Pushrod Set: Recoil 18
PRB-1156	Trim Tab Set: Recoil 18
PRB-1157	Propeller Strut Set: Recoil 18
PRB-1158	Flex Shaft Set: Recoil 18
PRB-1159	Stuffing Tube: Recoil 18
SPMX-1029	Firma 2931 2950Kv 8-Pole Outrunner Marine Motor
PRB-1204	Motor Coupler: Recoil 18
PRB-1205	Canopy, Shreddy: Recoil 18
PRB-1397	Canopy, Heatwave: Recoil 18
SPMSR315	SR315 DSMR 3CH Receiver
SPMXME1030	Firma 30A Brushless Marine ESC 2-3S
HRZ00007	Horizon® 13g Servo Metal Gear Waterproof
PRB0313	Propeller: MG17, IM17
SPMXC1020	Smart S120 USB-C Charger, 1x20W

## Optional Parts

Part #	Description
PRB-1374	Stainless Steel Propeller: Recoil 2 18
DYN4403	GPS Speed Meter 2.0
SPM5115C	DX5C Smart 5-Channel Transmitter Combo with SR315 Receiver
SPMSSX108	SX108 Micro Metal Gear Servo
SPMXBC100	XBC100 Smart LiPo Battery Checker & Servo Driver
SPMXC2000	S2100 G2 2x100W AC Smart Charger
SPMXC2050	S155 G2 1x55W AC Smart Charger

## Recommended Parts

Part #	Description
DYN5500	Magnum Force 2 Motor Spray, 13 oz
DYNE4200	Grease Gun with Marine Grease, 5oz
DYNM0102	Clear Flexible Marine Tape (18M)
DYNT0502	Start Up Tool Set: Pro Boat

## Troubleshooting Guide

Problem	Possible Cause	Solution
Boat will not respond to throttle but responds to other controls	Throttle channel is reversed	Reverse throttle channel on transmitter
Extra noise or extra vibration	Damaged propeller, shaft or motor	Replace damaged parts
	Propeller is out of balance	Balance or replace propeller
Reduced runtime or boat underpowered	Boat battery charge is low	Completely recharge battery
	Boat battery is damaged	Replace boat battery and follow battery instructions
	Blocking or friction on shaft or propeller	Disassemble, lubricate and correctly align parts
	Boat conditions may be too cold	Make sure the battery is warm (above 10° C [50° F]) before use
	Battery capacity may be too low for conditions	Replace battery or use a larger capacity battery
	Drive dog is too near the stuffing tube	Loosen drive shaft side of the motor coupling and move drive shaft small amount back
	Too little lubricant on drive shaft	Fully lubricate drive shaft
Boat will not Bind (during binding) to transmitter	Vegetation or other obstacles block the rudder or propeller	Remove vegetation or obstacles from rudder or propeller
	Transmitter is too near boat during binding process	Move powered transmitter a few feet from boat, disconnect and reconnect battery to boat
	Boat or transmitter is too close to large metal object, wireless source or another transmitter	Move the boat and transmitter to another location and attempt binding again
	Another compatible transmitter is powered on within range of the receiver	Power off all compatible transmitters except the one you are trying to bind
	Boat battery/Transmitter battery charge is too low	Replace/recharge batteries
Boat will not connect (after binding) to transmitter	ESC switch is off	Power on ESC switch
	Transmitter is too near boat during connecting process	Move powered transmitter a few feet from boat, disconnect and reconnect battery to boat
	Boat or transmitter is too close to large metal object, wireless source or another transmitter	Move boat or transmitter to another location and attempt to connect again
	Boat battery/transmitter battery charge is too low	Replace/recharge batteries
Boat tends to dive in the water or takes on water	ESC switch is off	Power on ESC switch
	The boat hull is not completely closed	Dry out the boat and ensure the hatch is fully closed on the hull before returning the boat to the water
	Center of gravity is too far forward	Move batteries back in the hull
Boat tends to turn one direction	Trim tabs are angled incorrectly	Angle each trim tab up a small amount to lift the bow or down a small amount to lower the bow
	Rudder or rudder trim is not centered	Repair rudder or adjust rudder and rudder trim for straight running when control is at neutral
Rudder does not move	Vertical fins are angled incorrectly	Adjust the right or left fin angle for straight running when control is at neutral
	Rudder, linkage or servo damage	Replace or repair damaged parts and adjust controls
	Steering servo wire is damaged or connections are loose	Do a check of steering servo wires and connections, connect or replace as needed
	Transmitter is not bound correctly	Re-bind
	BEC (Battery Elimination Circuit) of the ESC is damaged	Replace ESC
Controls reversed	ESC switch is off	Power on ESC switch
	Transmitter settings are reversed	Perform the Control Direction Test and adjust controls on transmitter appropriately
Motor overheats	Blocked water cooler tubes	Clean or replace water tubes
Motor power pulses then motor loses power	Weather conditions might be too cold	Postpone until weather is warmer
	Battery is old, worn out or damaged	Replace battery

## 2-Year Limited Warranty

**What This Warranty Covers** — Horizon Hobby, LLC, (Horizon) warrants to the original purchaser that the product purchased (the “Product”) will be free from defects in materials and workmanship for two years from the date of purchase.

**What is Not Covered** — This warranty is not transferable and does not cover (i) cosmetic damage, (ii) damage due to acts of God, accident, misuse, abuse, negligence, commercial use, or due to improper use, installation, operation or maintenance, (iii) modification of or to any part of the Product, (iv) attempted service by anyone other than a Horizon Hobby authorized service center, (v) Product not purchased from an authorized Horizon dealer, or (vi) Product not compliant with applicable technical regulations or (vii) use that violates any applicable laws, rules, or regulations.

OTHER THAN THE EXPRESS WARRANTY ABOVE, HORIZON MAKES NO OTHER WARRANTY OR REPRESENTATION, AND HEREBY DISCLAIMS ANY AND ALL IMPLIED WARRANTIES, INCLUDING, WITHOUT LIMITATION, THE IMPLIED WARRANTIES OF NON-INFRINGEMENT, MERCHANTABILITY AND FITNESS FOR A PARTICULAR PURPOSE. THE PURCHASER ACKNOWLEDGES THAT THEY ALONE HAVE DETERMINED THAT THE PRODUCT WILL SUITABLY MEET THE REQUIREMENTS OF THE PURCHASER’S INTENDED USE.

**Purchaser’s Remedy** — Horizon’s sole obligation and purchaser’s sole and exclusive remedy shall be that Horizon will, at its option, either (i) service, or (ii) replace, any Product determined by Horizon to be defective. Horizon reserves the right to inspect any and all Product(s) involved in a warranty claim. Service or replacement decisions are at the sole discretion of Horizon. Proof of purchase is required for all warranty claims. SERVICE OR REPLACEMENT AS PROVIDED UNDER THIS WARRANTY IS THE PURCHASER’S SOLE AND EXCLUSIVE REMEDY.

**Limitation of Liability** — HORIZON SHALL NOT BE LIABLE FOR SPECIAL, INDIRECT, INCIDENTAL OR CONSEQUENTIAL DAMAGES, LOSS OF PROFITS OR PRODUCTION OR COMMERCIAL LOSS IN ANY WAY, REGARDLESS OF WHETHER SUCH CLAIM IS BASED IN CONTRACT, WARRANTY, TORT, NEGLIGENCE, STRICT LIABILITY OR ANY OTHER THEORY OF LIABILITY, EVEN IF HORIZON HAS BEEN ADVISED OF THE POSSIBILITY OF SUCH DAMAGES. Further, in no event shall the liability of Horizon exceed the individual price of the Product on which liability is asserted. As Horizon has no control over use, setup, final assembly, modification or misuse, no liability shall be assumed nor accepted for any resulting damage or injury. By the act of use, setup or assembly, the user accepts all resulting liability. If you as the purchaser or user are not prepared to accept the liability associated with the use of the Product, purchaser is advised to return the Product immediately in new and unused condition to the place of purchase.

**Law** — These terms are governed by Illinois law (without regard to conflict of law principals). This warranty gives you specific legal rights, and you may also have other rights which vary from state to state. Horizon reserves the right to change or modify this warranty at any time without notice.

### WARRANTY SERVICES

**Questions, Assistance, and Services** — Your local hobby store and/or place of purchase cannot provide warranty support or service. Once assembly, setup or use of the Product has been started, you must contact your local distributor or Horizon directly. This will enable Horizon to better answer your questions and service you in the event that you may need any assistance. For questions or assistance,

please visit our website at [www.horizonhobby.com](http://www.horizonhobby.com), submit a Product Support Inquiry, or call the toll free telephone number referenced in the Warranty and Service Contact Information section to speak with a Product Support representative.

**Inspection or Services** — If this Product needs to be inspected or serviced and is compliant in the country you live and use the Product in, please use the Horizon Online Service Request submission process found on our website or call Horizon to obtain a Return Merchandise Authorization (RMA) number. Pack the Product securely using a shipping carton. Please note that original boxes may be included, but are not designed to withstand the rigors of shipping without additional protection. Ship via a carrier that provides tracking and insurance for lost or damaged parcels, as Horizon is not responsible for merchandise until it arrives and is accepted at our facility. An Online Service Request is available at [http://www.horizonhobby.com/content/service-center\\_render-service-center](http://www.horizonhobby.com/content/service-center_render-service-center). If you do not have internet access, please contact Horizon Product Support to obtain a RMA number along with instructions for submitting your product for service. When calling Horizon, you will be asked to provide your complete name, street address, email address and phone number where you can be reached during business hours. When sending product into Horizon, please include your RMA number, a list of the included items, and a brief summary of the problem. A copy of your original sales receipt must be included for warranty consideration. Be sure your name, address, and RMA number are clearly written on the outside of the shipping carton.

**NOTICE:** Do not ship LiPo batteries to Horizon. If you have any issue with a LiPo battery, please contact the appropriate Horizon Product Support office.

**Warranty Requirements** — For Warranty consideration, you must include your original sales receipt verifying the proof-of-purchase date. Provided warranty conditions have been met, your Product will be serviced or replaced free of charge. Service or replacement decisions are at the sole discretion of Horizon.

**Non-Warranty Service** — Should your service not be covered by warranty, service will be completed and payment will be required without notification or estimate of the expense unless the expense exceeds 50% of the retail purchase cost.

By submitting the item for service you are agreeing to payment of the service without notification. Service estimates are available upon request. You must include this request with your item submitted for service. Non-warranty service estimates will be billed a minimum of ½ hour of labor. In addition you will be billed for return freight. Horizon accepts money orders and cashier’s checks, as well as Visa, MasterCard, American Express, and Discover cards. By submitting any item to Horizon for service, you are agreeing to Horizon’s Terms and Conditions found on our website [http://www.horizonhobby.com/content/service-center\\_render-service-center](http://www.horizonhobby.com/content/service-center_render-service-center).

**ATTENTION:** Horizon service is limited to Product compliant in the country of use and ownership. If received, a non-compliant Product will not be serviced. Further, the sender will be responsible for arranging return shipment of the un-serviced Product, through a carrier of the sender’s choice and at the sender’s expense. Horizon will hold non-compliant Product for a period of 60 days from notification, after which it will be discarded.

## Warranty and Service Contact Information

Country of Purchase	Horizon Hobby	Contact Information	Address
United States of America	Horizon Service Center (Repairs and Repair Requests)	servicecenter.horizonhobby.com/RequestForm/	2904 Research Rd. Champaign, Illinois, 61822 USA
	Horizon Product Support (Product Technical Assistance)	productsupport@horizonhobby.com 800-338-4639	
	Sales	websales@horizonhobby.com 800-338-4639	
EU	Horizon Technischer Service	service@horizonhobby.de	Hanskampring 9 D 22885 Barsbüttel, Germany
	Sales: Horizon Hobby GmbH	+49 (0) 4121 2655 100	

## FCC Information

### FCC ID: BRWSPMSLT300, BRWSRIRVINGV1

This equipment complies with FCC and IC radiation exposure limits set forth for an uncontrolled environment. This equipment should be installed and operated with minimum distance 20cm between the radiator and/or antenna and your body (excluding fingers, hands, wrists, ankles and feet). This transmitter must not be co-located or operating in conjunction with any other antenna or transmitter.

### Supplier's Declaration of Conformity Pro Boat Recoil 2 18-Inch Self-Righting Deep-V Brushless Boat, RTR (PRB08053)

This device complies with part 15 of the FCC Rules. Operation is subject to the following two conditions: (1) This device may not cause harmful interference, and (2) this device must accept any interference received, including interference that may cause undesired operation.

 **CAUTION:** Changes or modifications not expressly approved by the party responsible for compliance could void the user's authority to operate the equipment.

**NOTE:** This equipment has been tested and found to comply with the limits for a Class B digital device, pursuant to part 15 of the FCC Rules. These limits are designed to provide reasonable protection

against harmful interference in a residential installation.

This equipment generates, uses and can radiate radio frequency energy and, if not installed and used in accordance with the instructions, may cause harmful interference to radio communications. However, there is no guarantee that interference will not occur in a particular installation. If this equipment does cause harmful interference to radio or television reception, which can be determined by turning the equipment off and on, the user is encouraged to try to correct the interference by one or more of the following measures:

- Reorient or relocate the receiving antenna.
- Increase the separation between the equipment and receiver.
- Connect the equipment into an outlet on a circuit different from that to which the receiver is connected.
- Consult the dealer or an experienced radio/TV technician for help.

Horizon Hobby, LLC  
2904 Research Rd., Champaign, IL 61822  
Email: compliance@horizonhobby.com  
Web: HorizonHobby.com

## IC Information

### CAN ICES-3 (B)/NMB-3(B)

### IC: 6157A-SPMSLT300, 6157A-SRIRVINGV1

This device contains license-exempt transmitter(s)/receiver(s) that comply with Innovation, Science, and Economic Development Canada's license-exempt RSS(s). Operation is subject to the following 2 conditions:

1. This device may not cause interference.
2. This device must accept any interference, including interference that may cause undesired operation of the device.

## Compliance Information for the European Union

### EU Compliance Statement: Pro Boat Recoil 2 18-Inch Self-Righting Deep-V Brushless Boat, RTR (PRB08053)

Hereby, Horizon Hobby, LLC declares that the device is in compliance with the following: EU Low Voltage Directive 2014/35/EU; EU EMC Directive 2014/30/EU; EU Radio Equipment Directive 2014/53/EU; RoHS 2 Directive 2011/65/EU; RoHS 3 Directive - Amending 2011/65/EU Annex II 2015/863.

The full text of the EU declaration of conformity is available at the following internet address: <https://www.horizonhobby.com/content/support-render-compliance>.

**NOTE:** This product contains batteries that are covered under the 2006/66/EC European Directive, which cannot be disposed of with normal household waste. Please follow local regulations.

### Wireless Frequency Range and Wireless Output Power:

<b>Transmitter:</b>	<b>Receiver:</b>
2403-2480MHz	2404-2476MHz
16.3 dBm	-1.33 dBm

### EU Manufacturer of Record:

Horizon Hobby, LLC  
2904 Research Road  
Champaign, IL 61822 USA

### EU Importer of Record:

Horizon Hobby, GmbH  
Hanskampring 9  
22885 Barsbüttel Germany

### WEEE NOTICE:



This appliance is labeled in accordance with European Directive 2012/19/EU concerning waste of electrical and electronic equipment (WEEE). This label indicates that this product should not be disposed of with household waste. It should be deposited at an appropriate facility to enable recovery and recycling.





**Exploded View  
Explosionszeichnungen  
Vues éclatées  
Viste esplose**

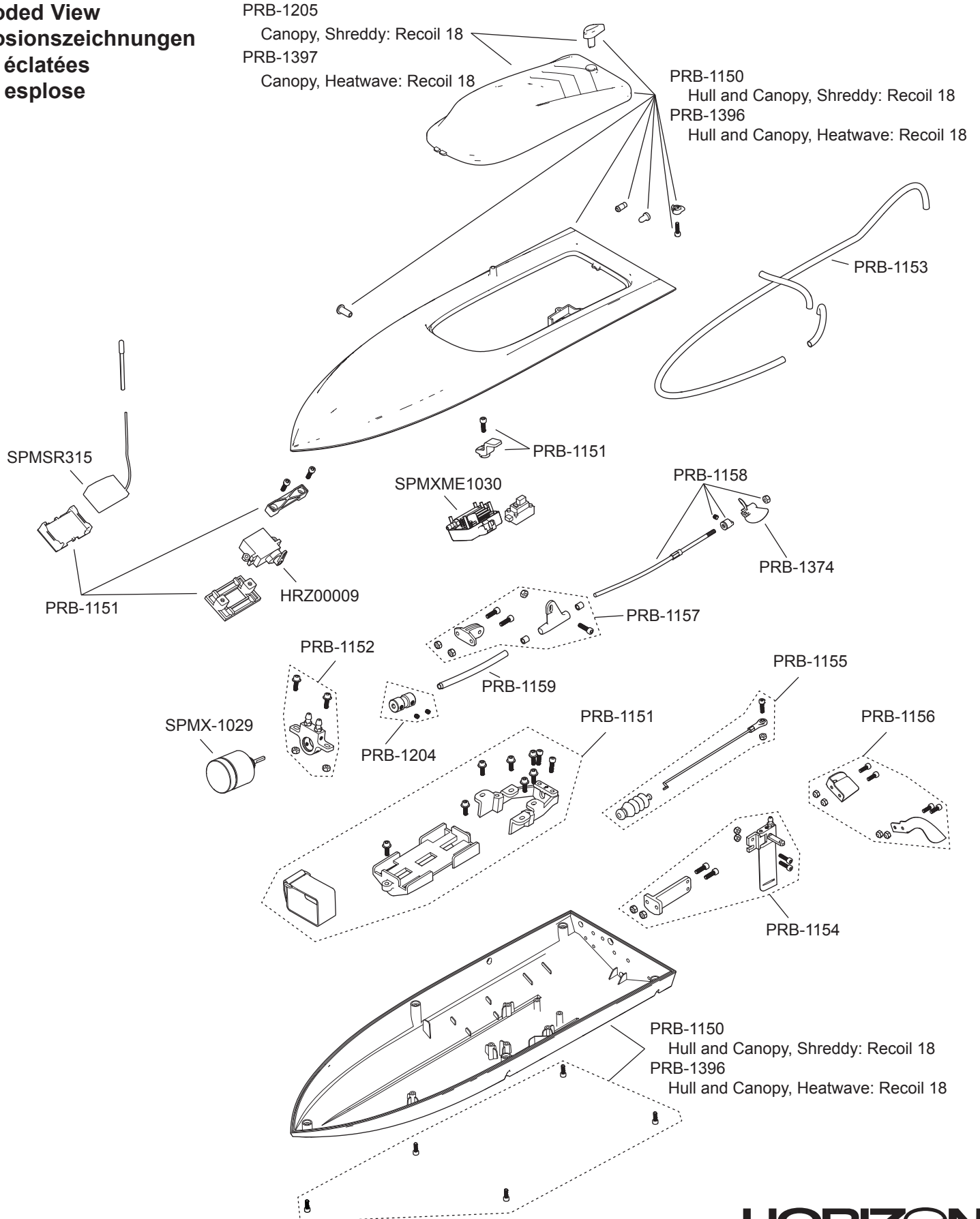





©2024 Horizon Hobby, LLC. Pro Boat, Recoil 2, SLT3, IC5, and the Horizon Hobby logo are trademarks or registered trademarks of Horizon Hobby, LLC. The Spektrum trademark is used with permission of Bachmann Industries, Inc. All other trademarks or registered trademarks are property of their respective owners. Other patents pending.

Created: 12/2023

PRB08053

593401