

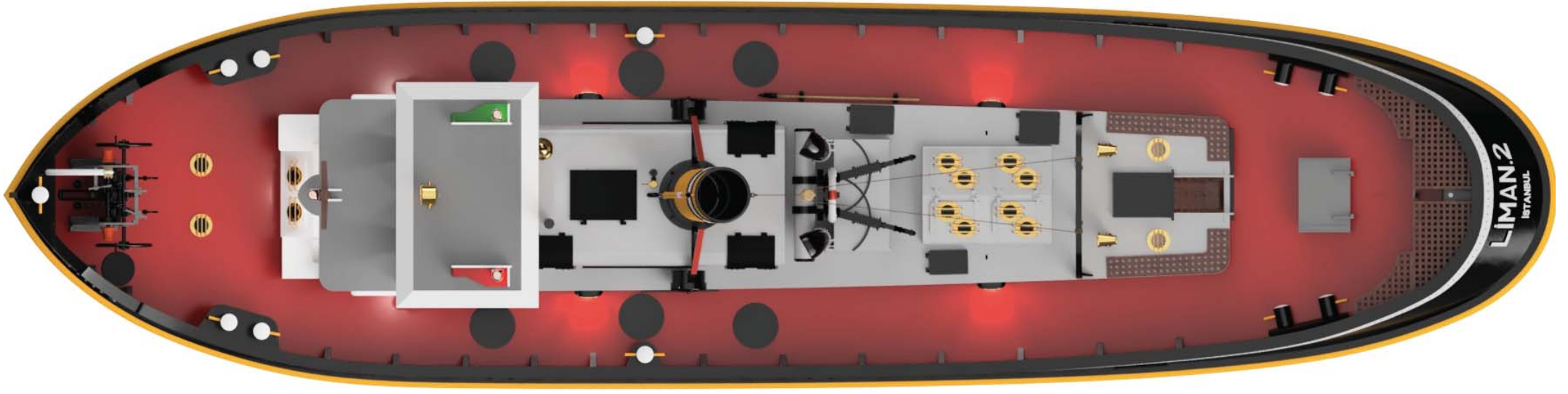

LİMAN.2

1:20 TUGBOAT



① *Exist the keel on a flat surface.
*Be sure all parts are placed right before gluing.

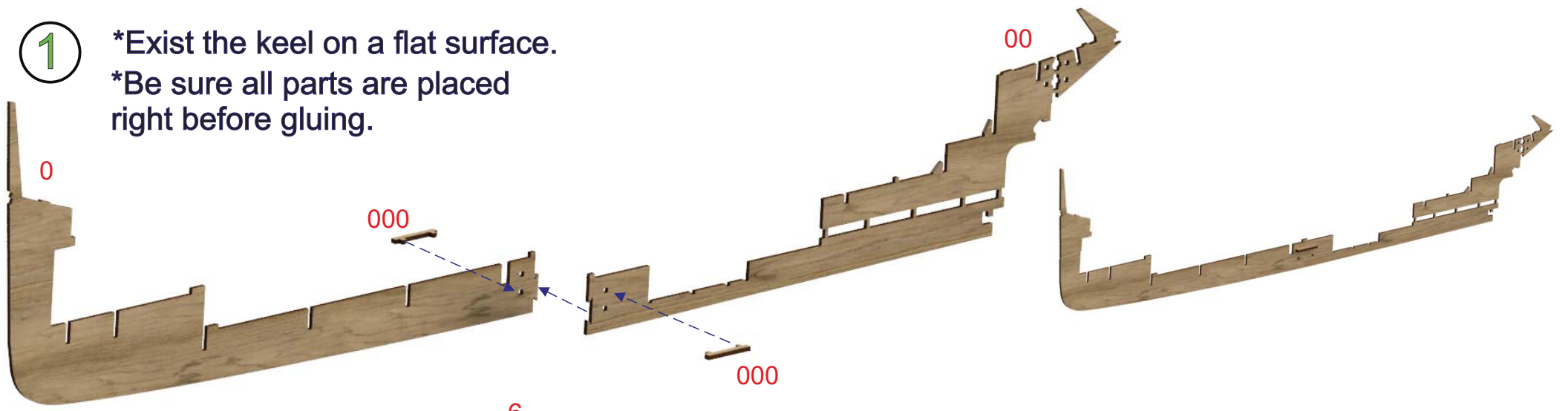

② *Watch the arrow pointer remains on the left while placing No:1 frame.

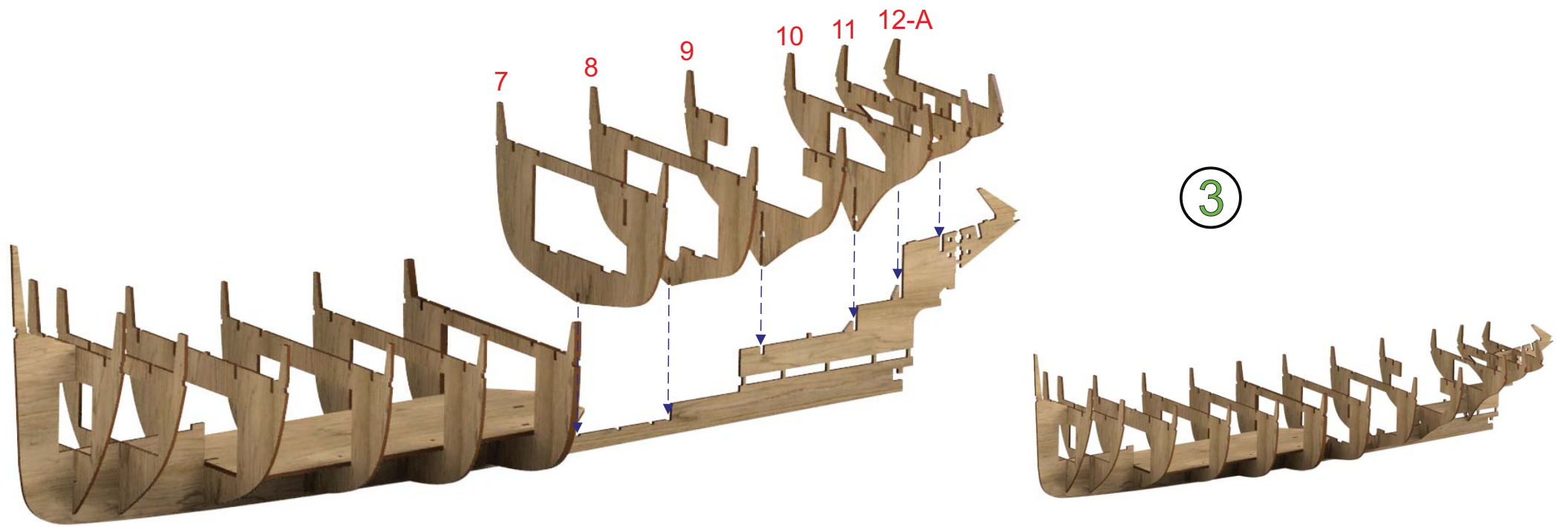
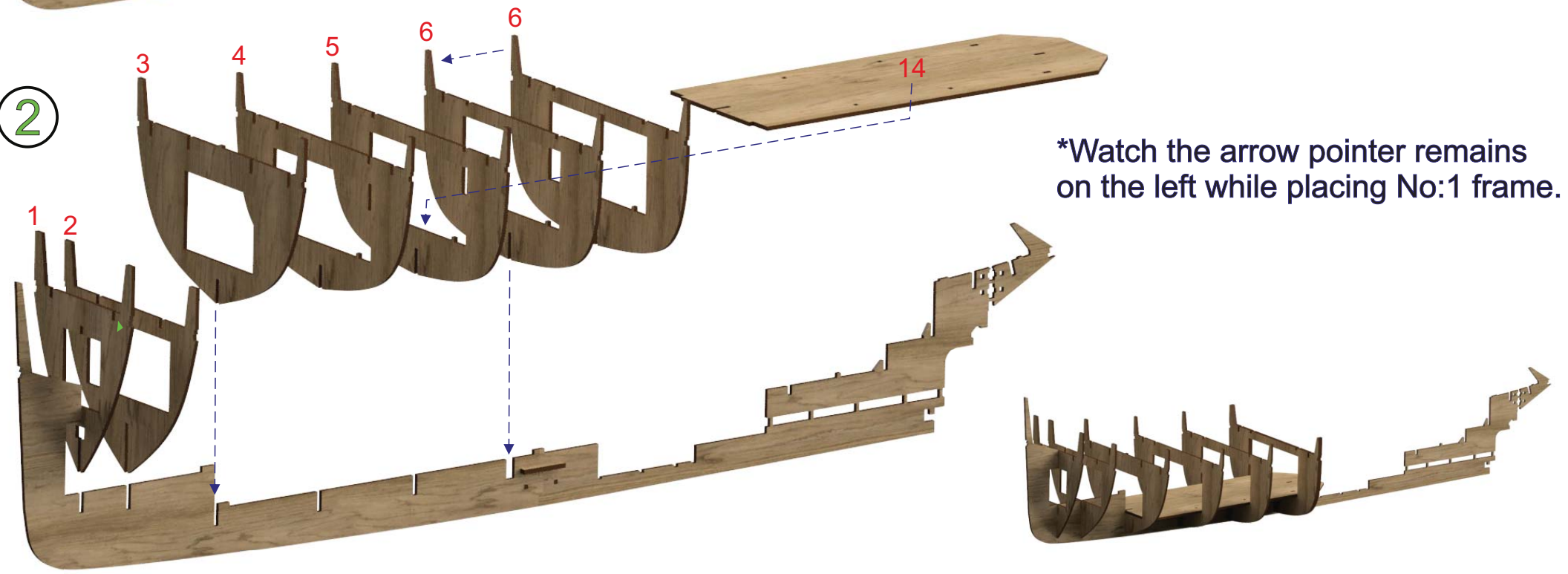

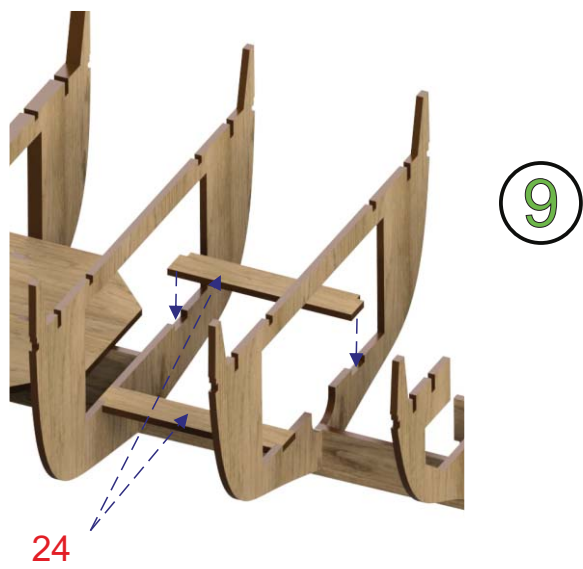
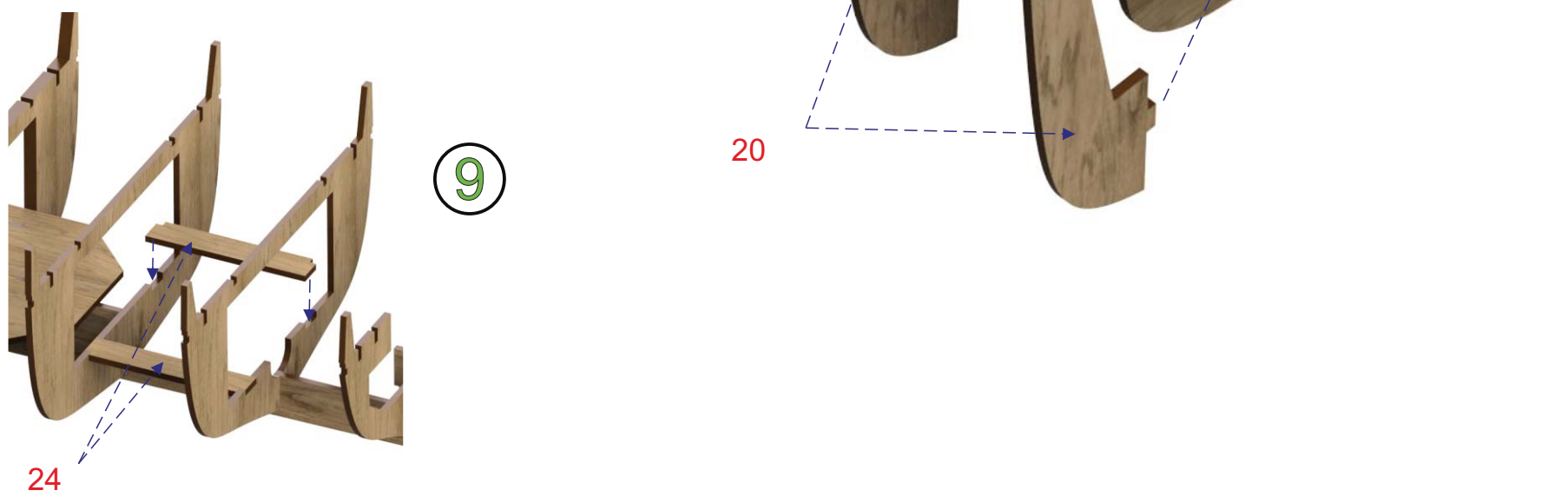
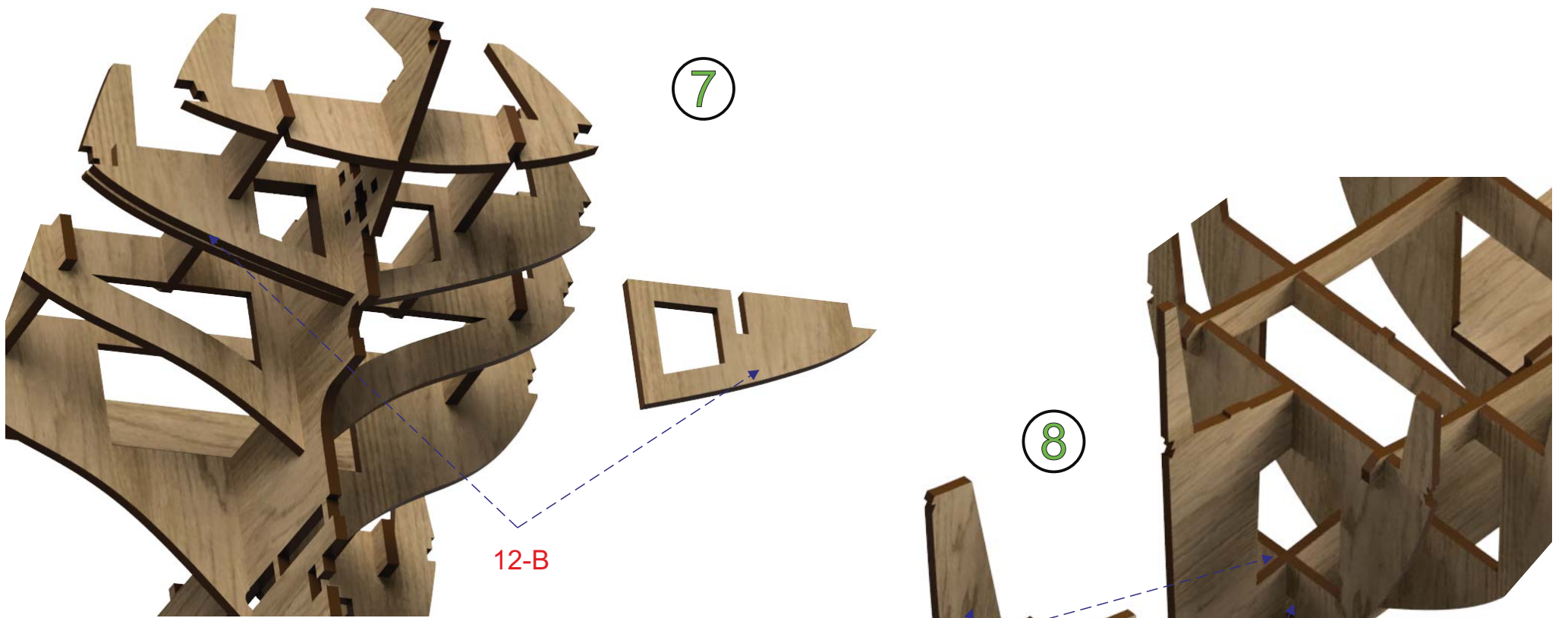
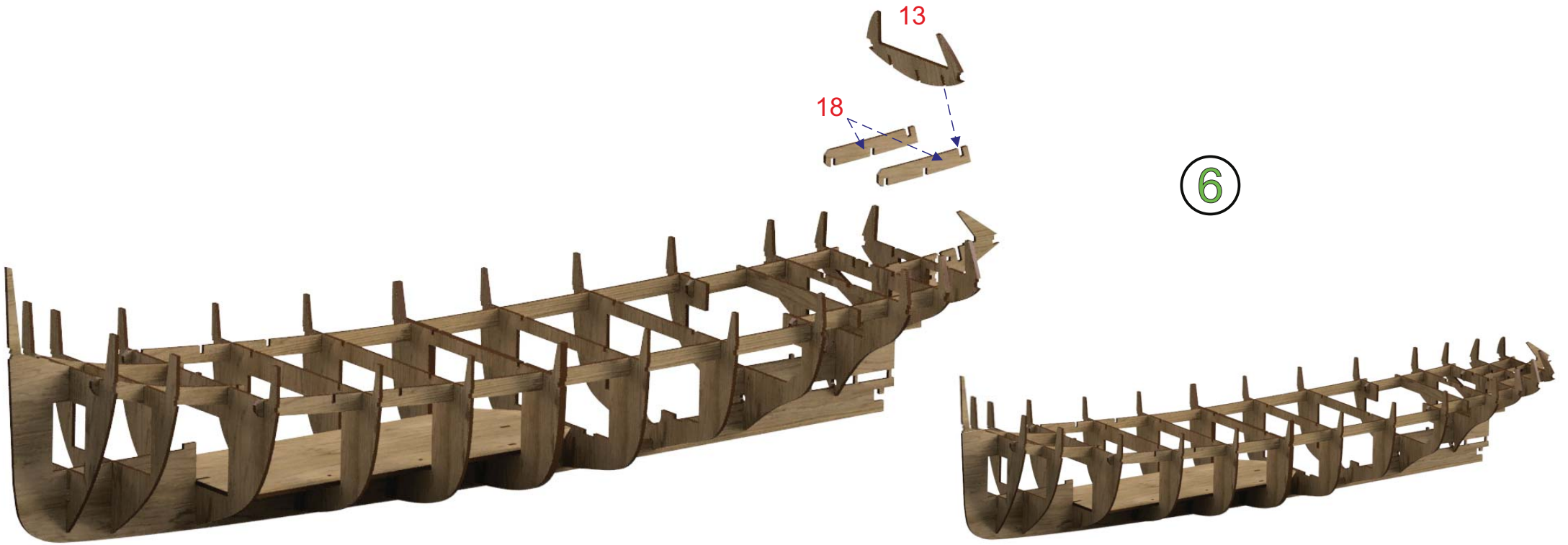
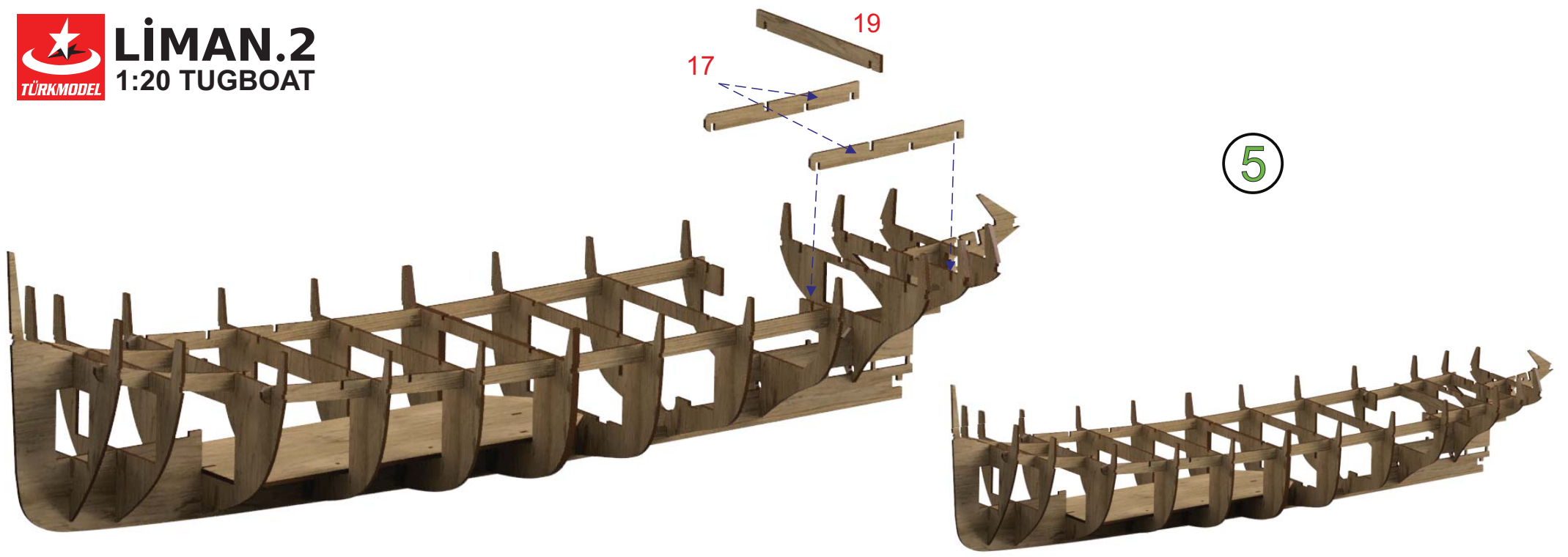

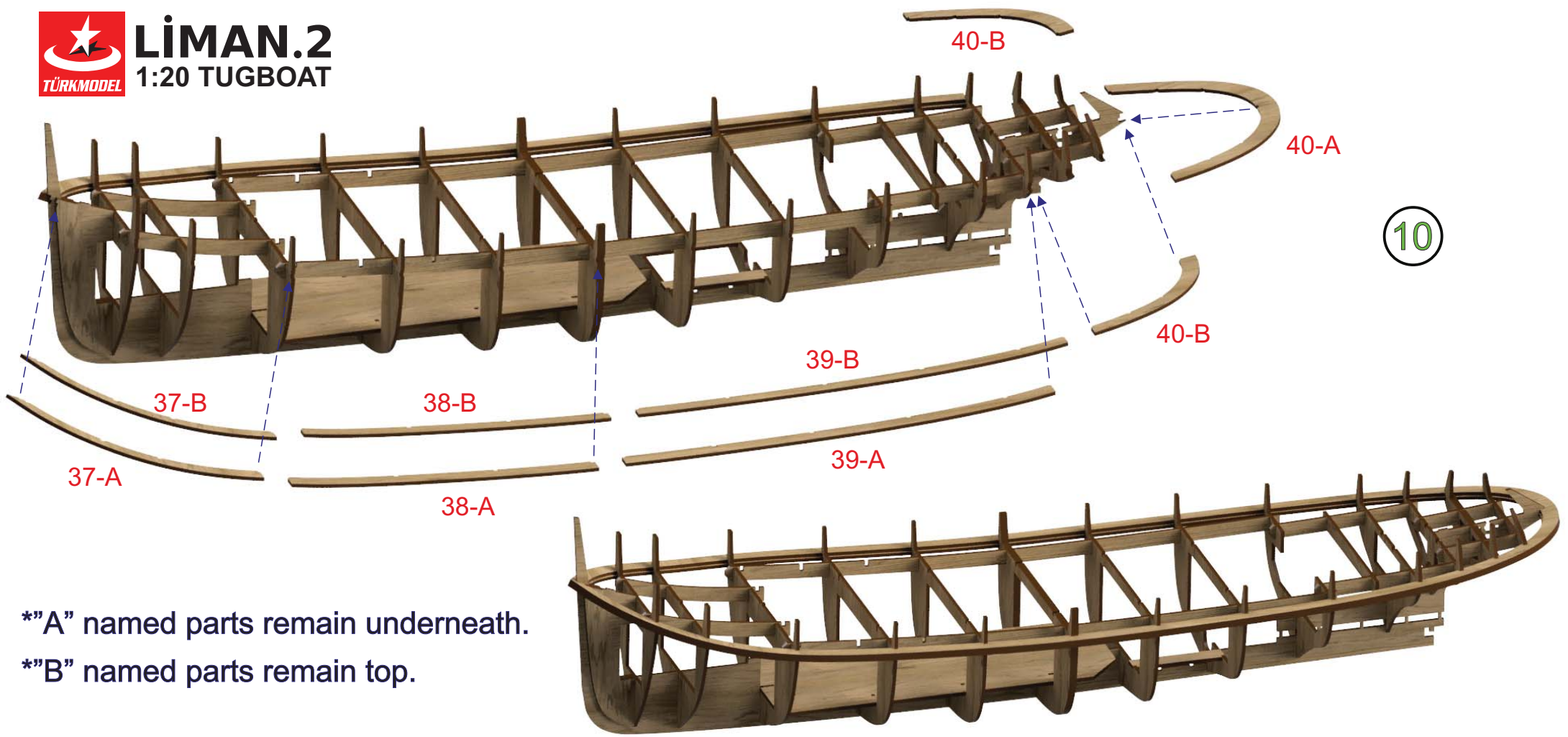

10

**"A" named parts remain underneath.
**"B" named parts remain top.

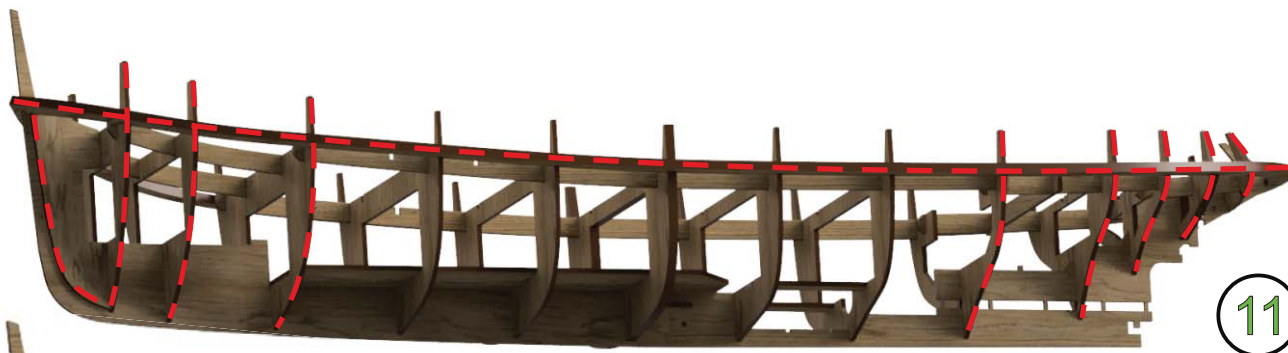

11

*Sand the frame edges to the angle of curving direction to make better contact the cover strips on the frames.
So, you can make hull in the right form.



12

*Cut off the nails as seen on the scene.

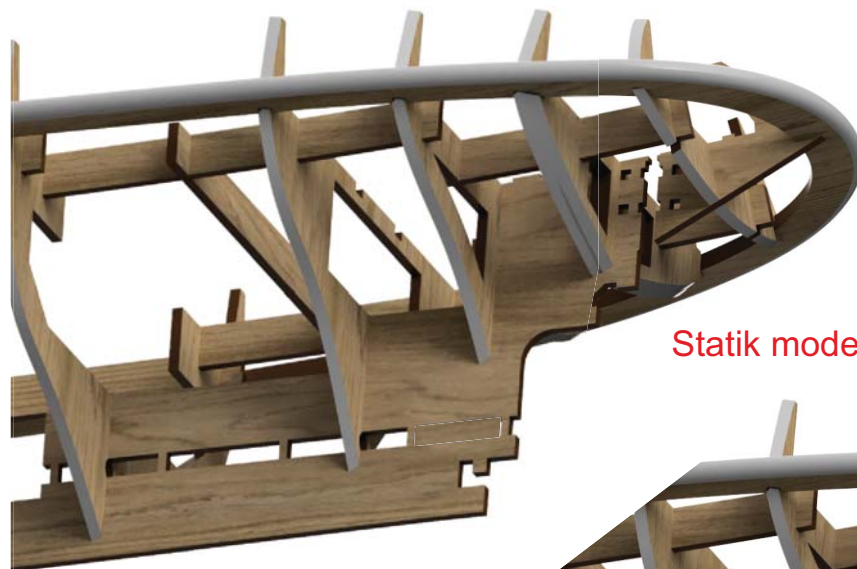
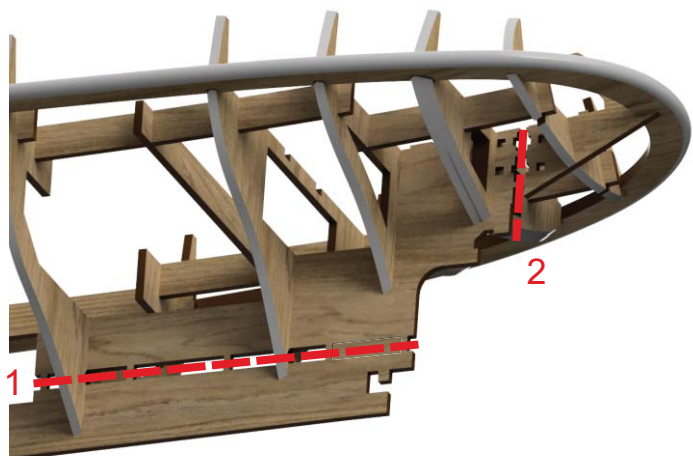

Statik model

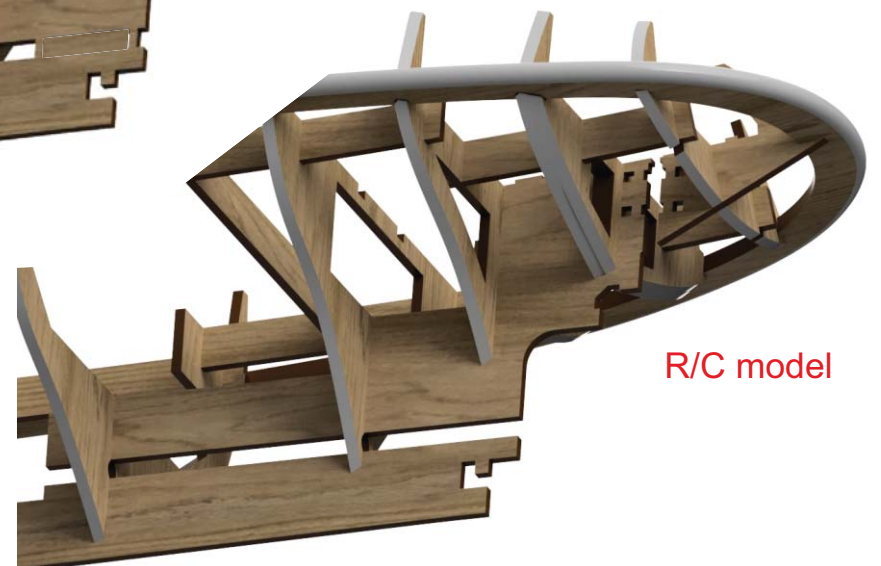

R/C model

*If you don't build R/C model, apply only 2. process.

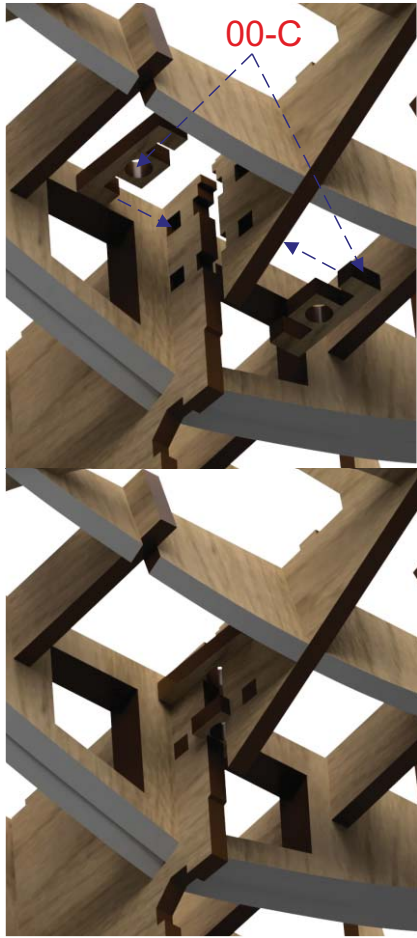

13



14

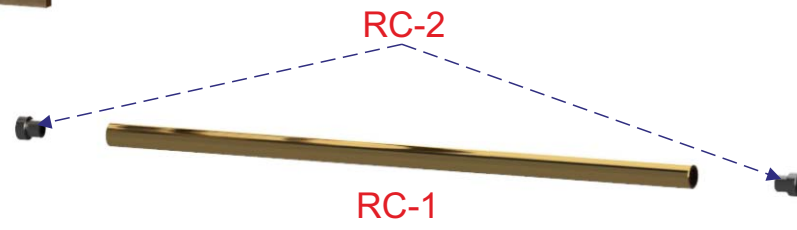
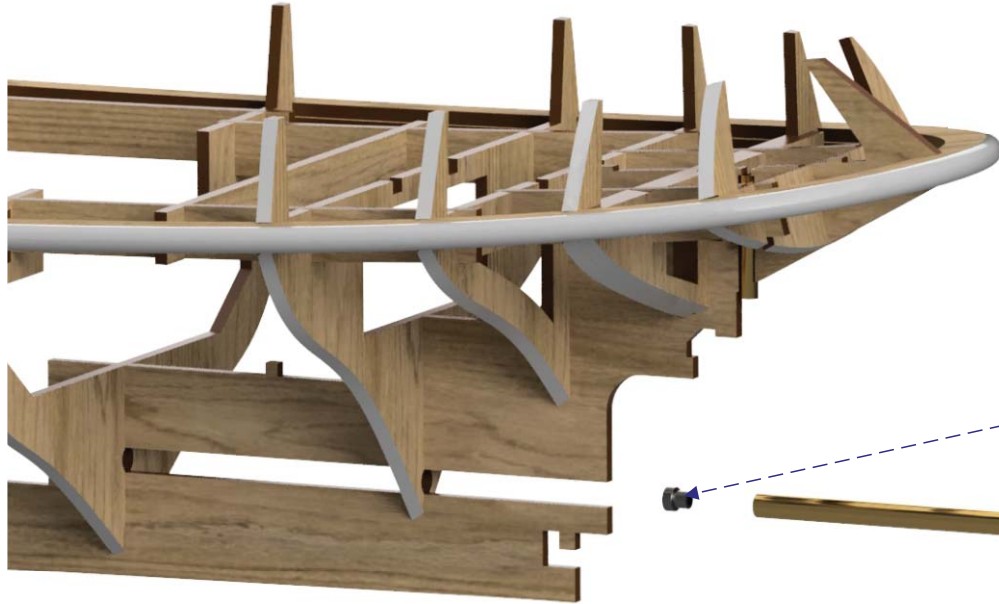

15

*Hammer the bushes after lubricant through the shaft pipe.

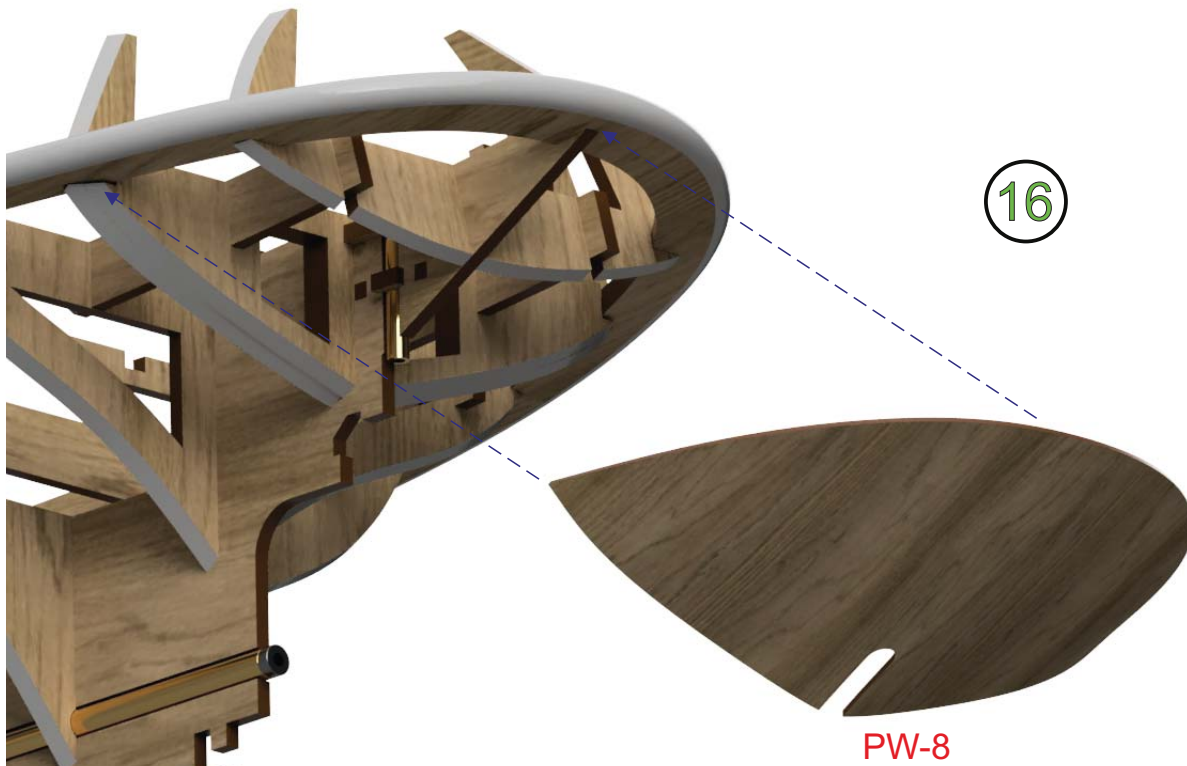

16



*You can glue easily as sanding the edge of part that touches lath.

17

*Keep the cover strips in water container for a while.
So that, it is attached and curved easily.
*You can stop the keel bending a side
If you cover one strip for each side everytime.

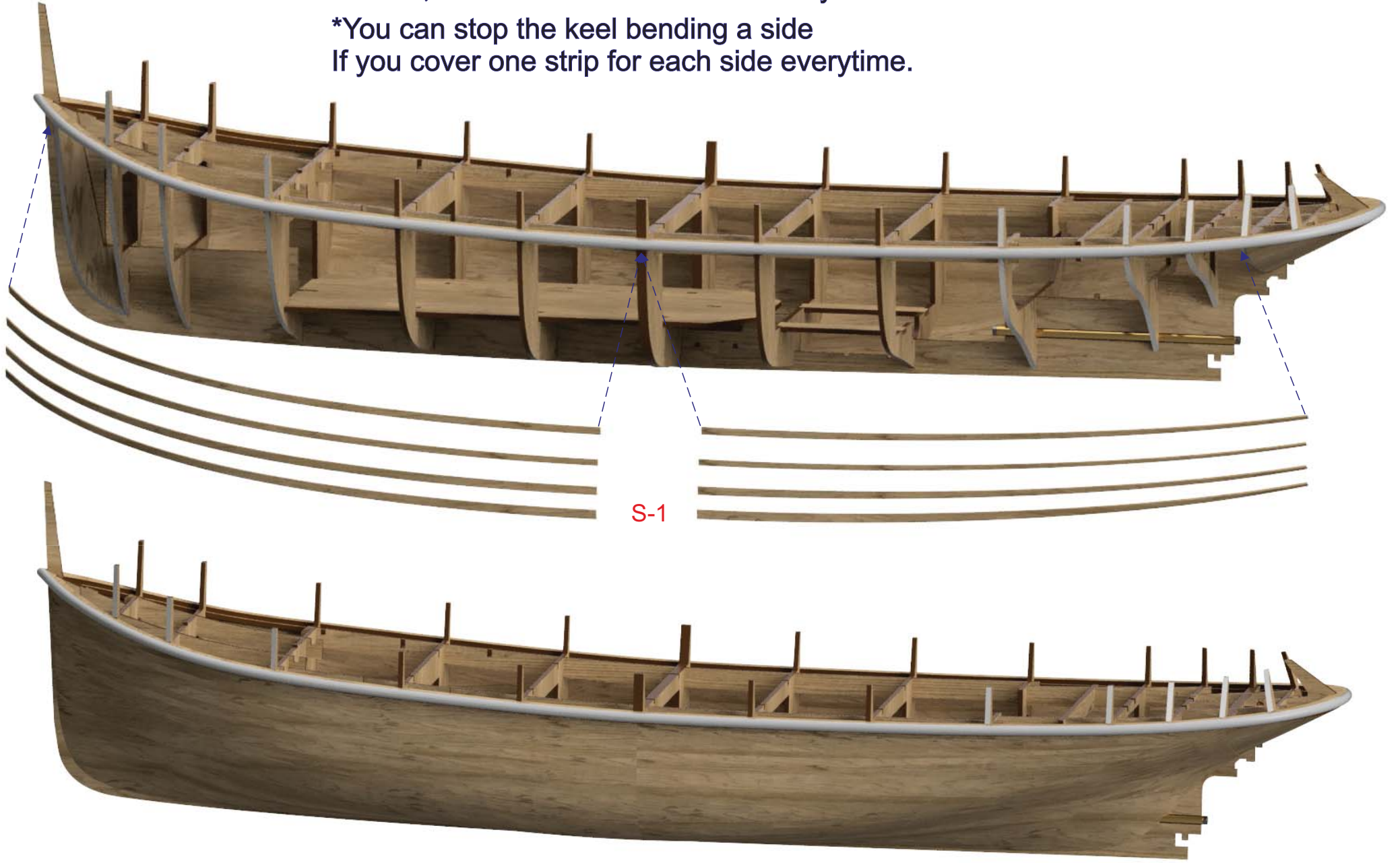

18

*Cut off the highlighted area of the frames.

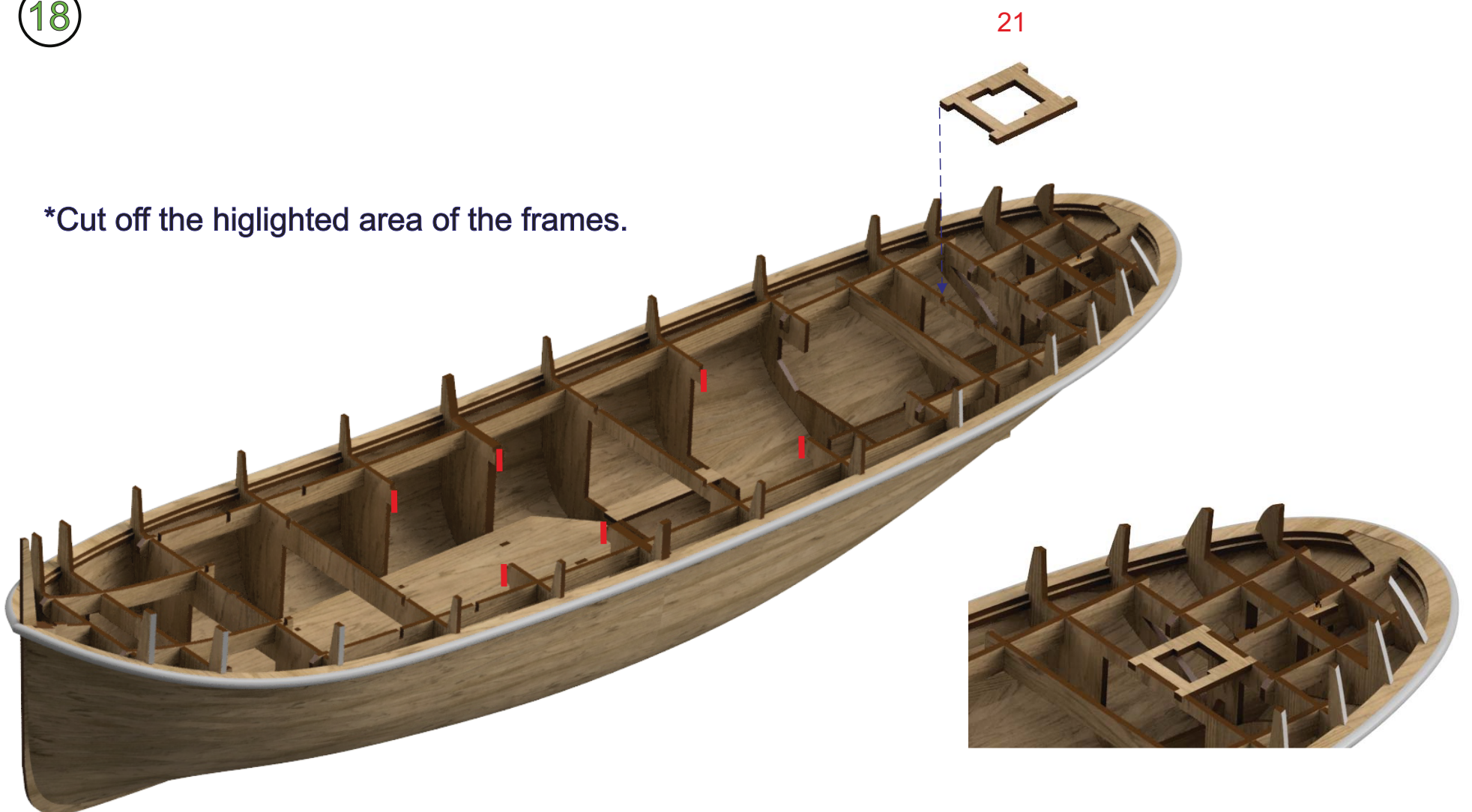

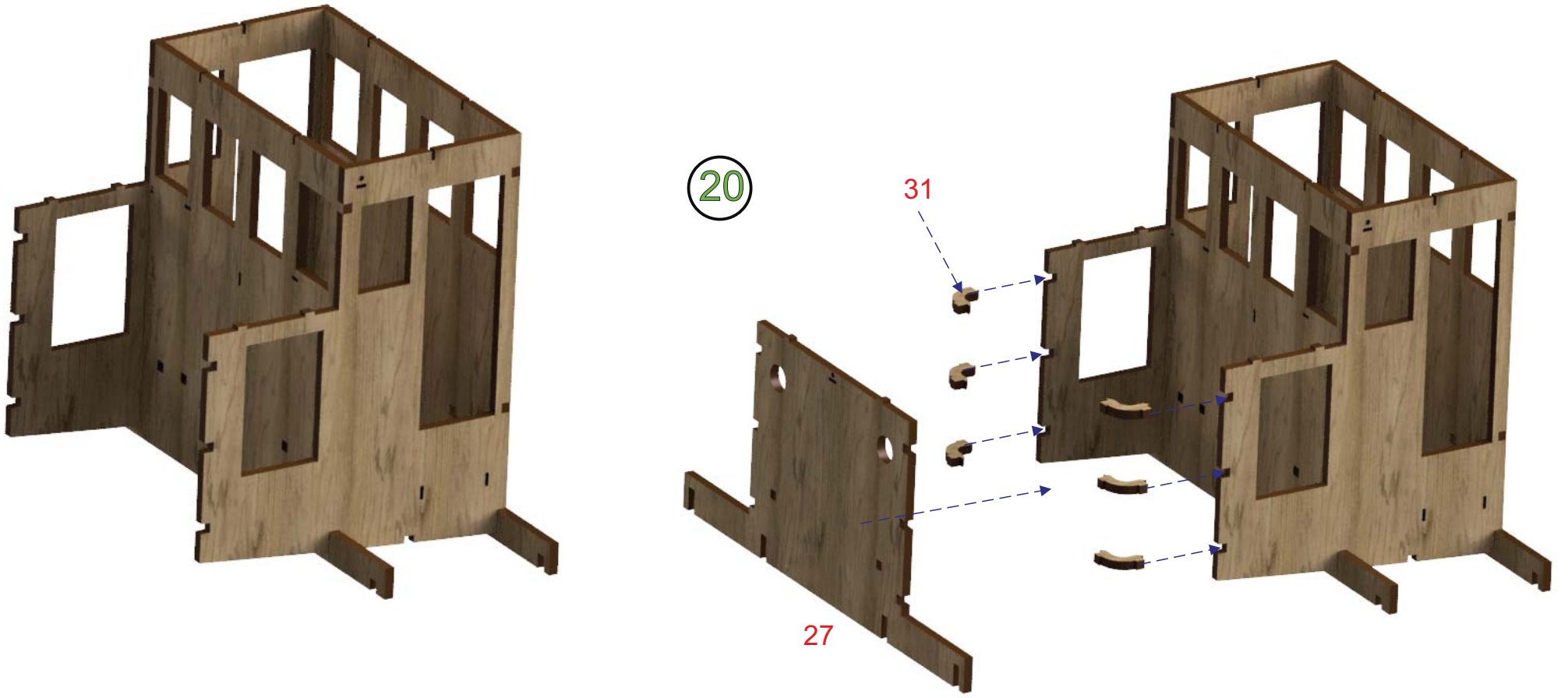
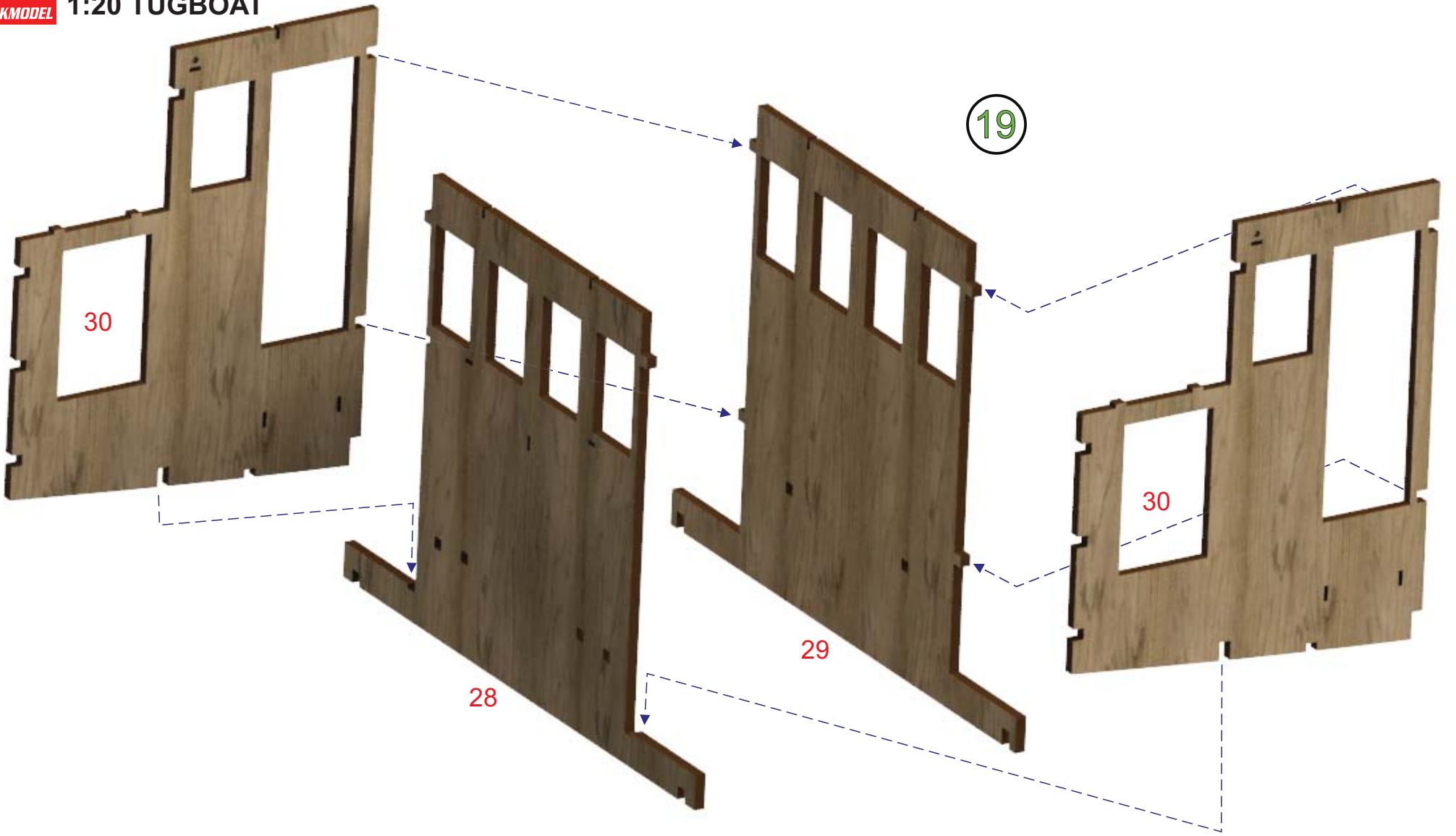

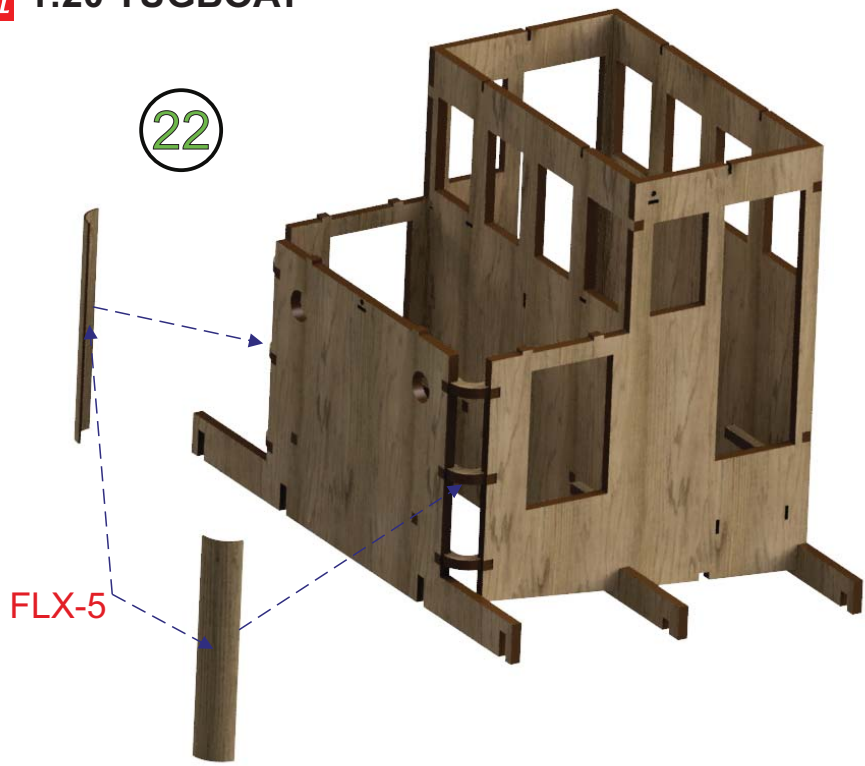

*Glue flexible parts as shaping carefully after keeping in a water container for 15-20 minutes.

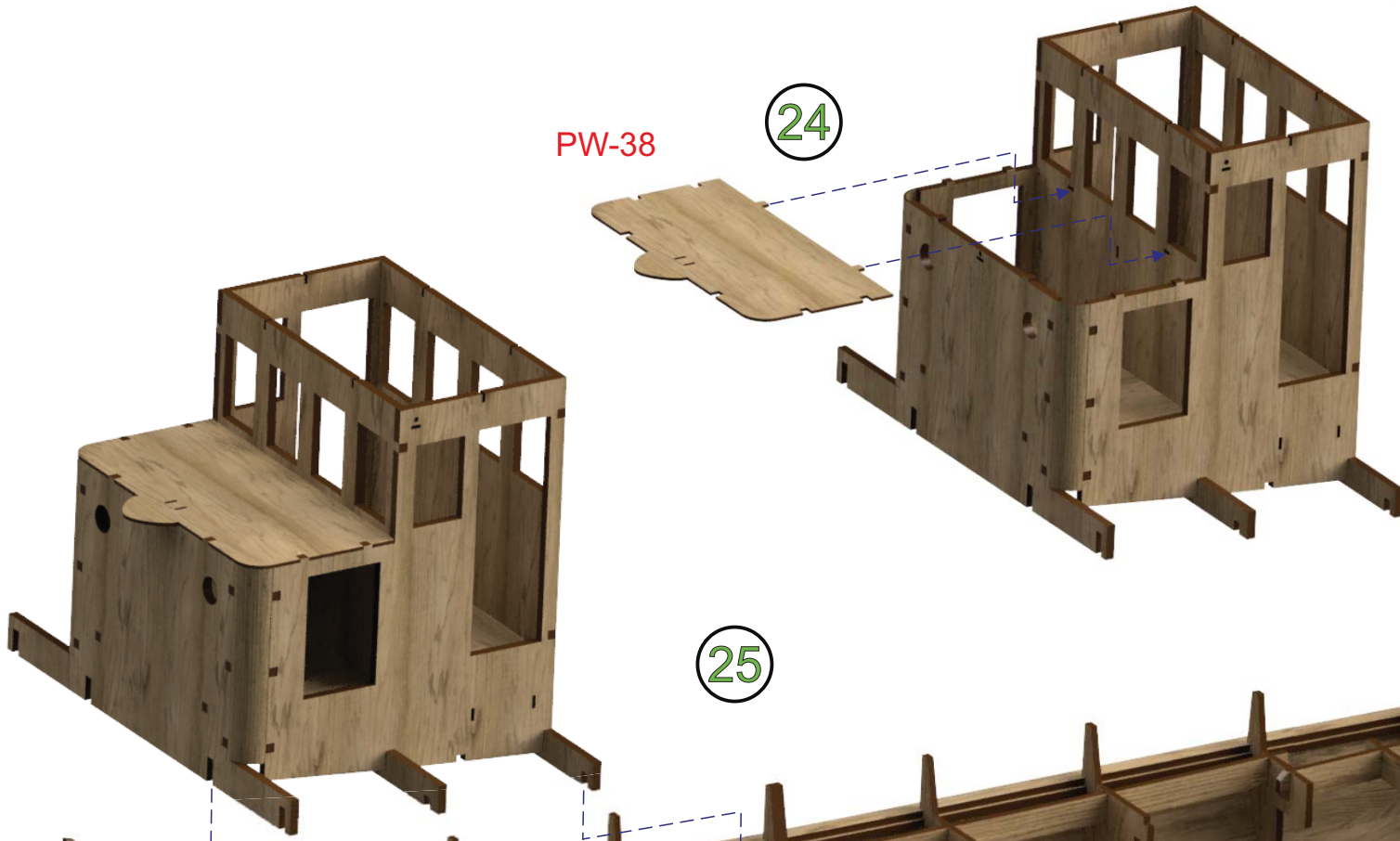

R/C SET-UP

Pass these stages If you don't build R/C model.
R/C equipment is sold seperatly, not included the kit.

26

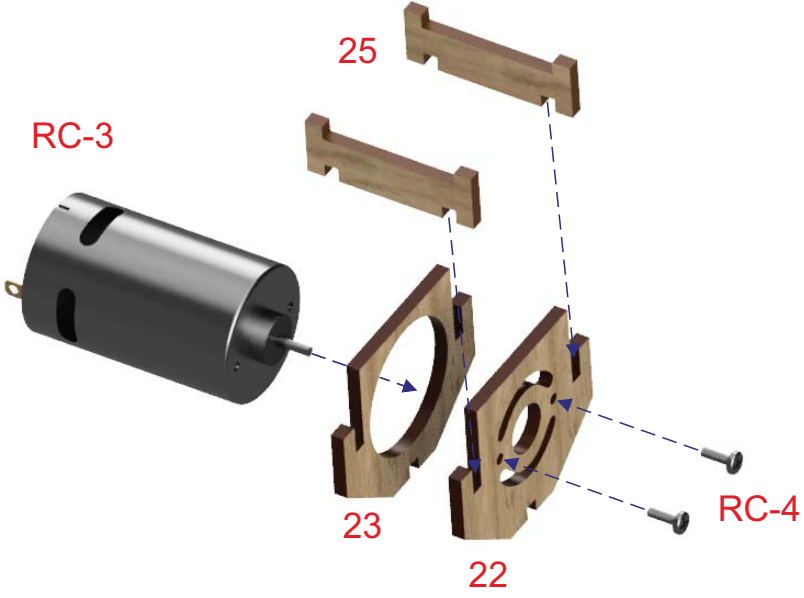

27

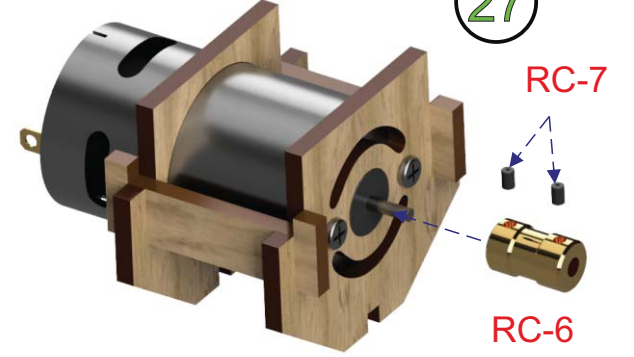

RC-5

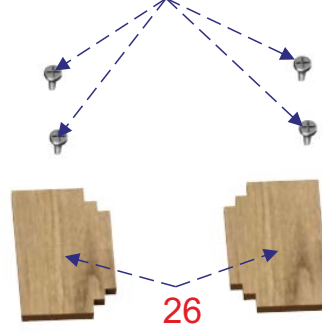

28

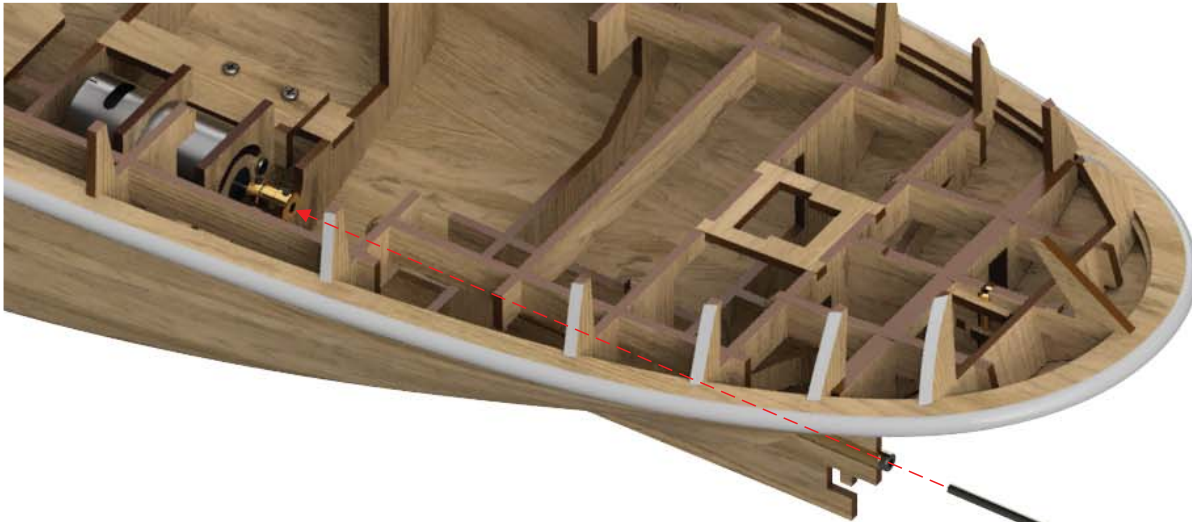
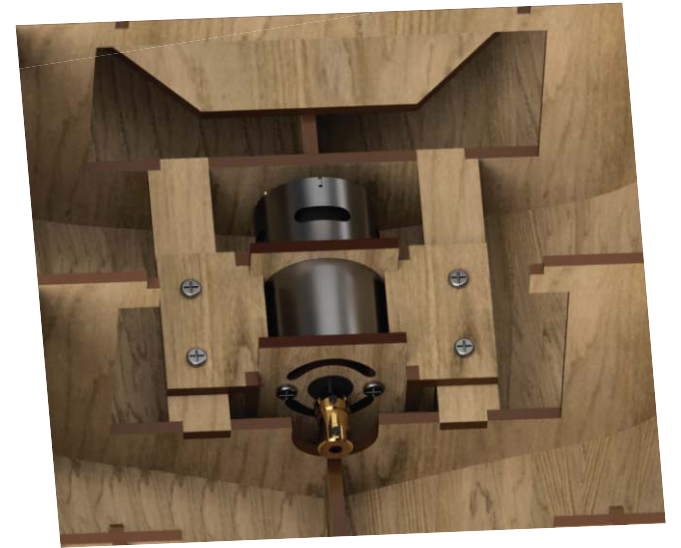

29

RC-8

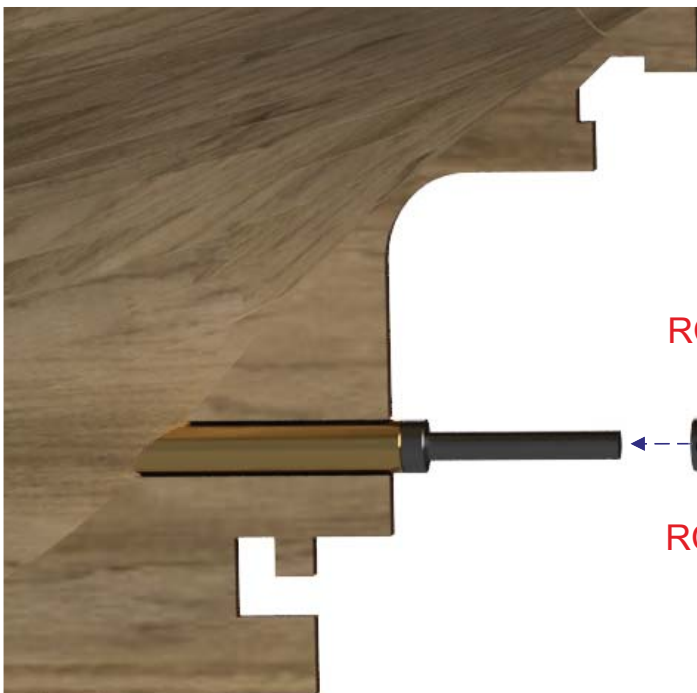

30

31

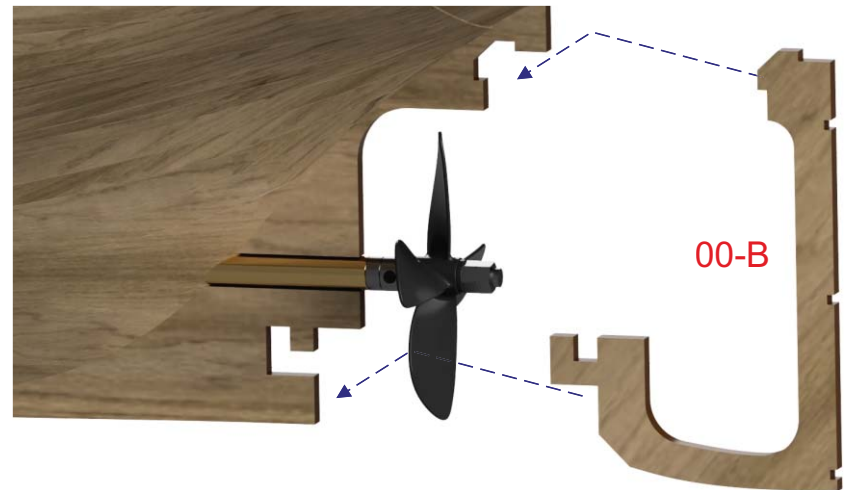

RC-12

00-B

32

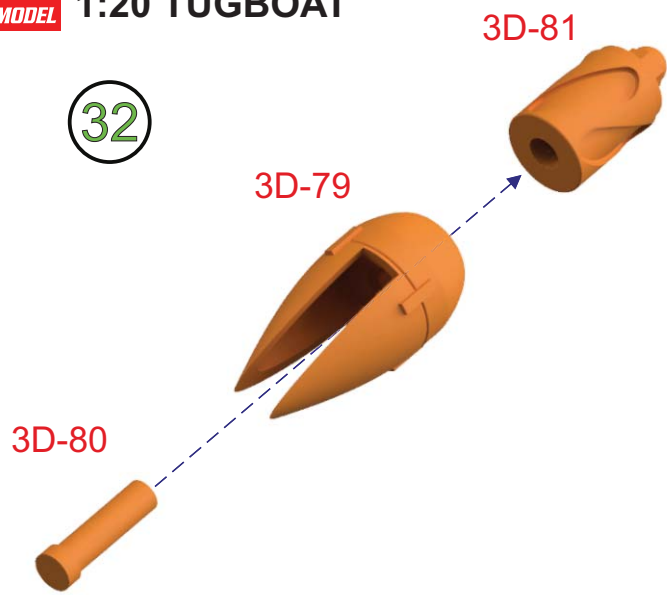

*Do not glue together 3D-79 and 3D-80.

*Watch not dropping glue on 3D-79 while gluing 3D-81 and 3D-80.

33

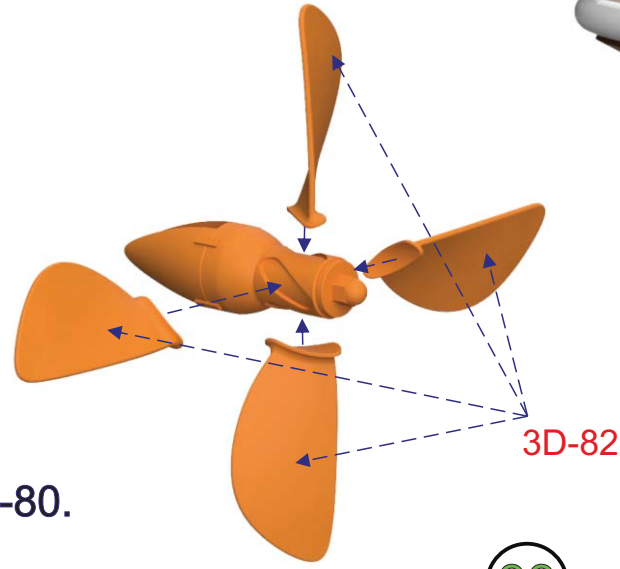

34

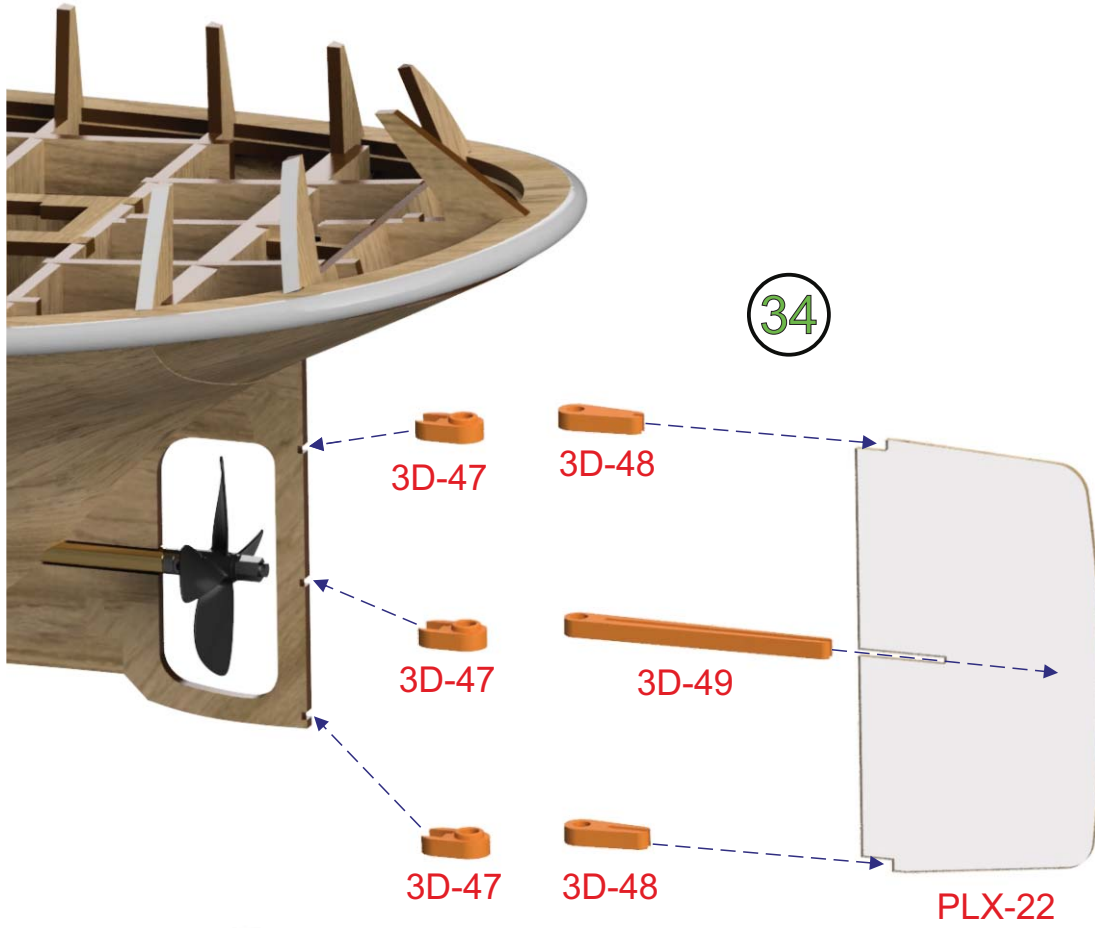

35



ME-4

*Hinges on the hull should not be glued rudder axle.

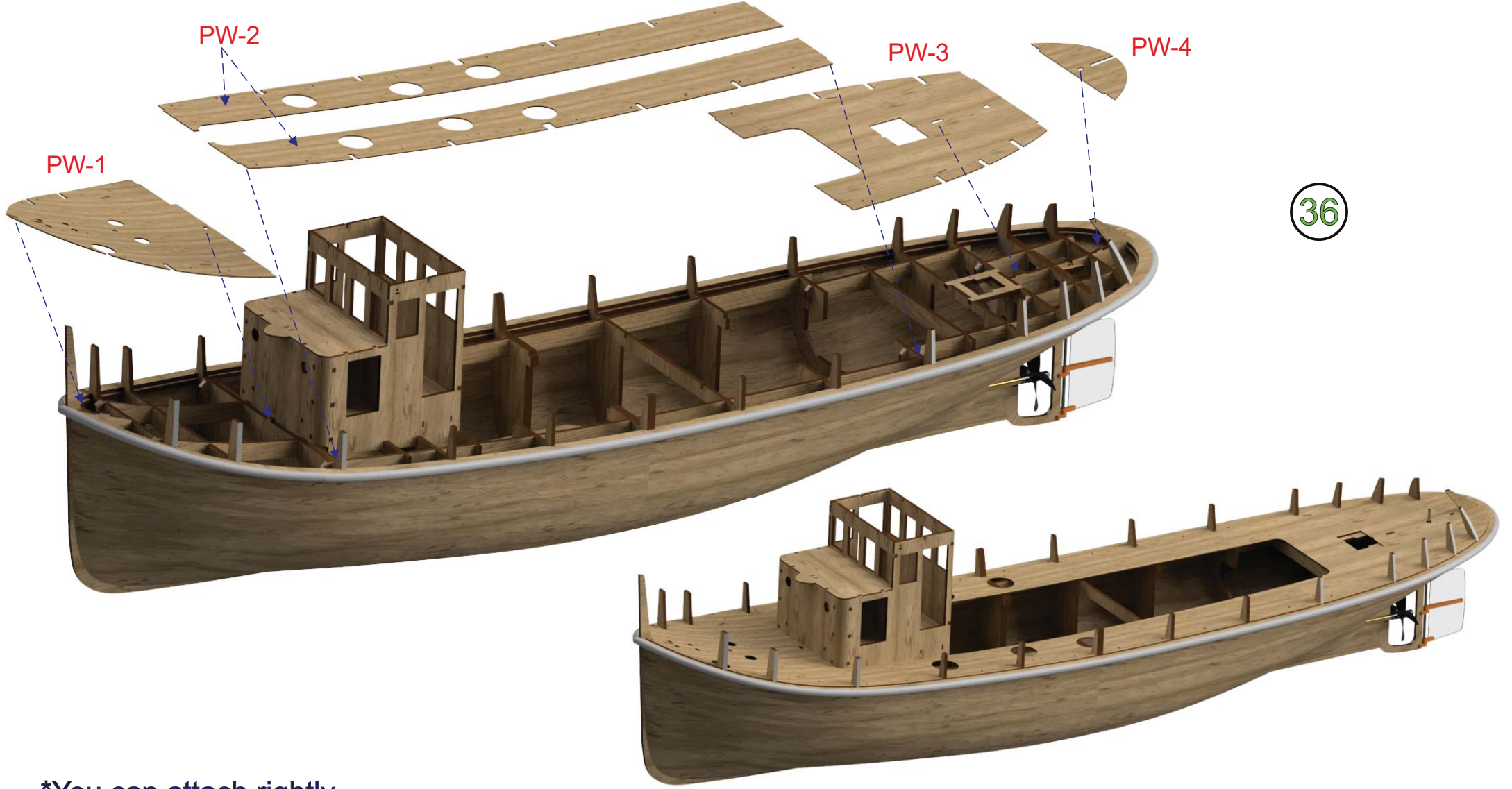

*You can attach rightly
If you sand front end of the panels.

*You should glue underneath of the panels
because of the frames will be cut off.

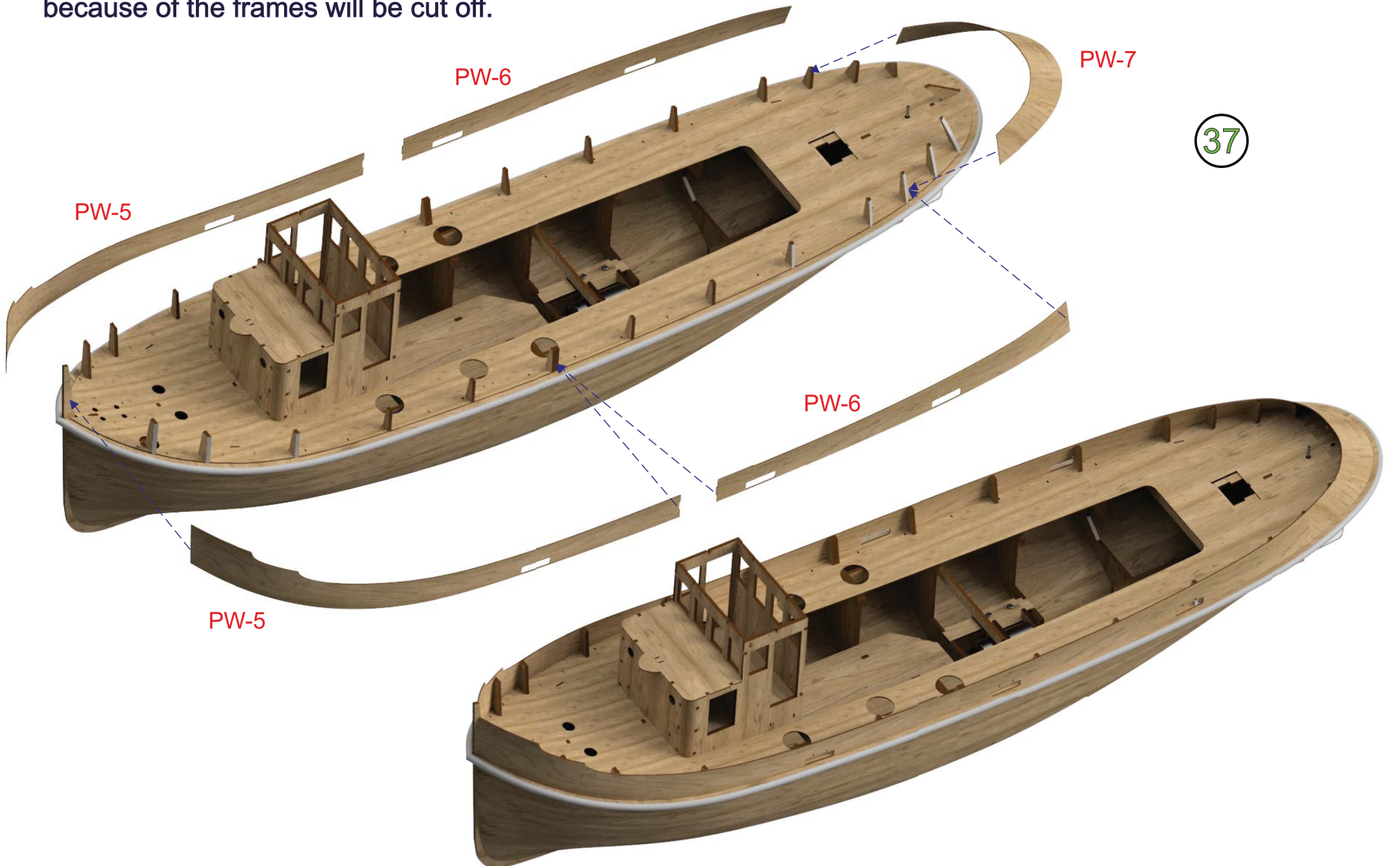

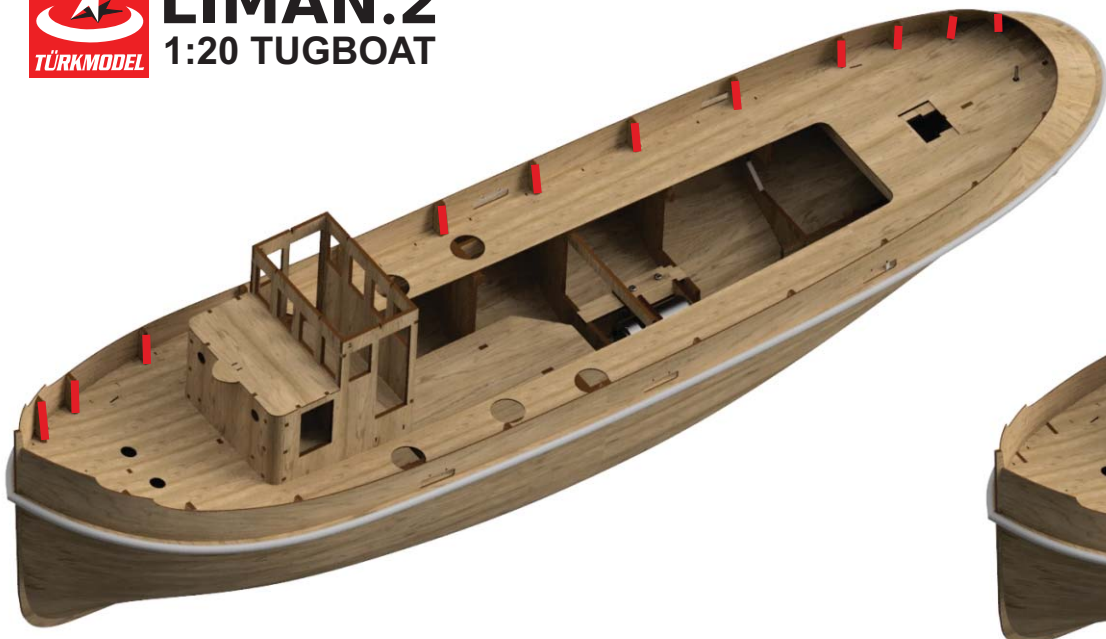

38



39

*The supports exists the same parts, but place them symmetrical.

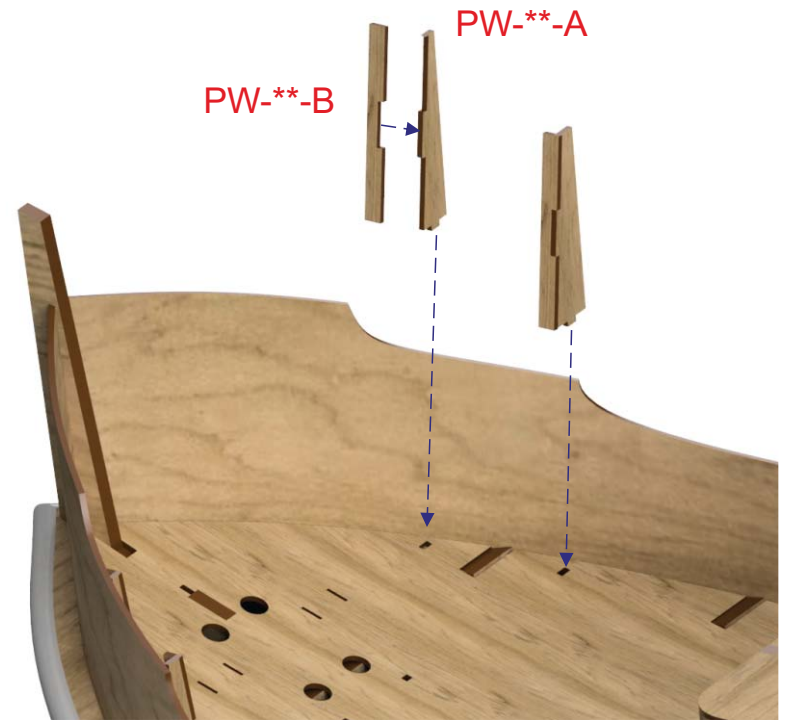

PW-**-B PW-**-A

40

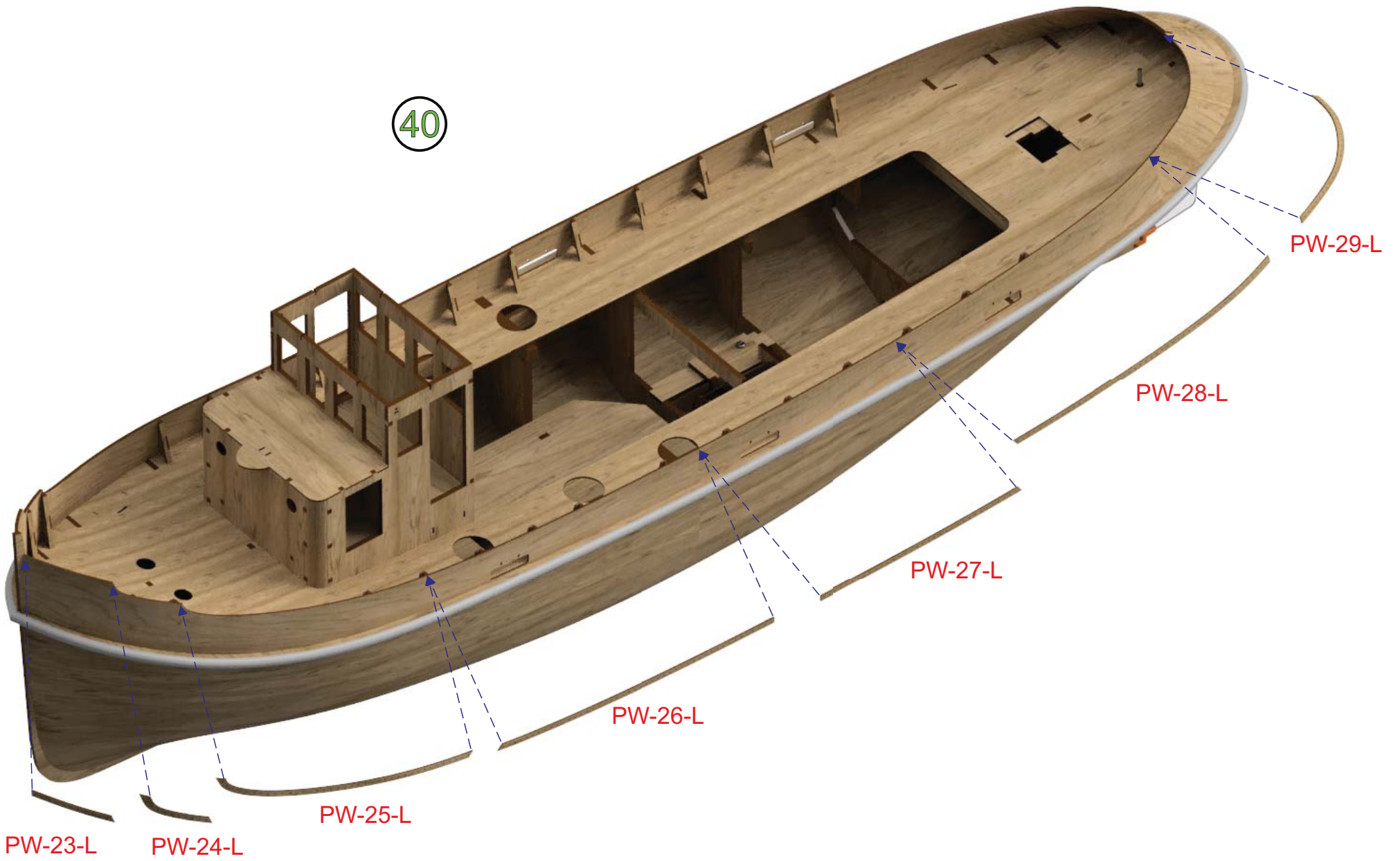

PW-23-L PW-24-L

PW-25-L

PW-26-L

PW-27-L

PW-28-L

PW-29-L

41 *You can shape the parts easily keeping in the water for a while.

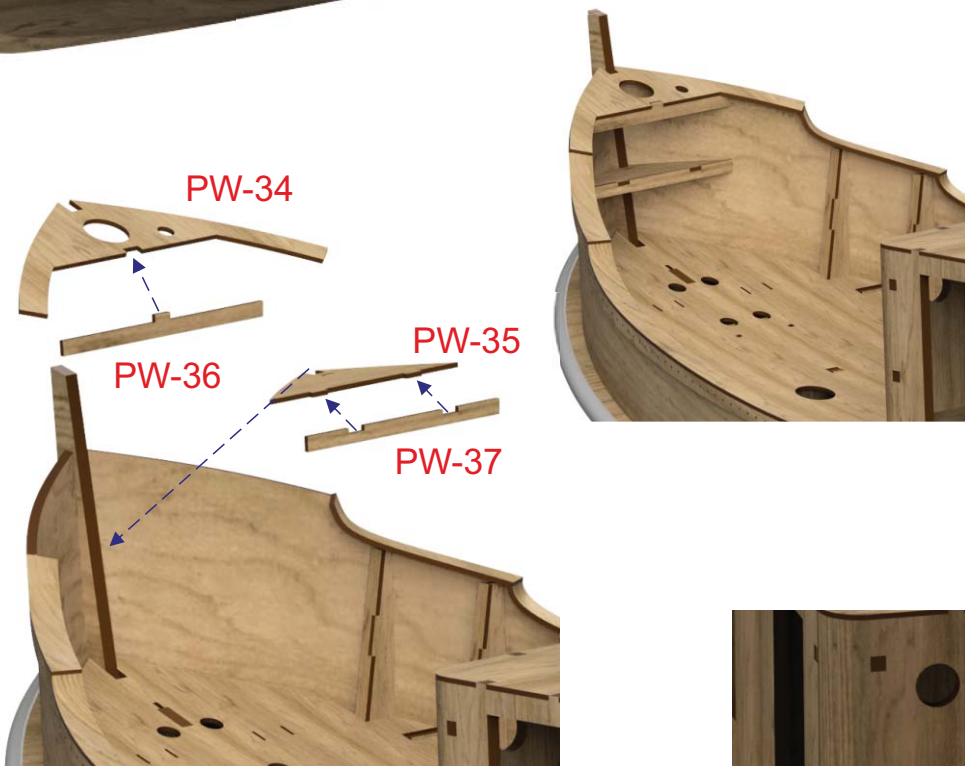
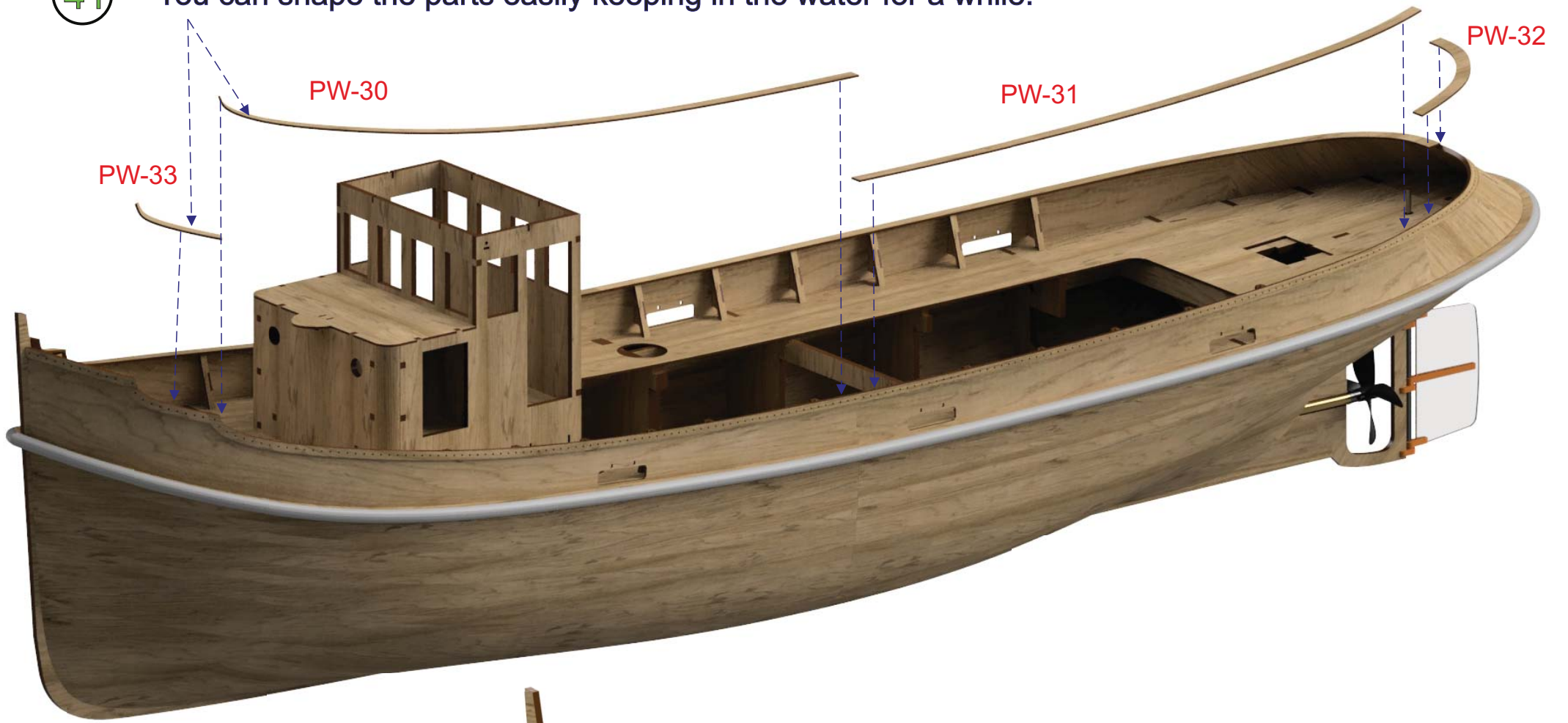

42



43

*Cut the letters off the sheet by model knife carefully and place highlighted place on the panel.

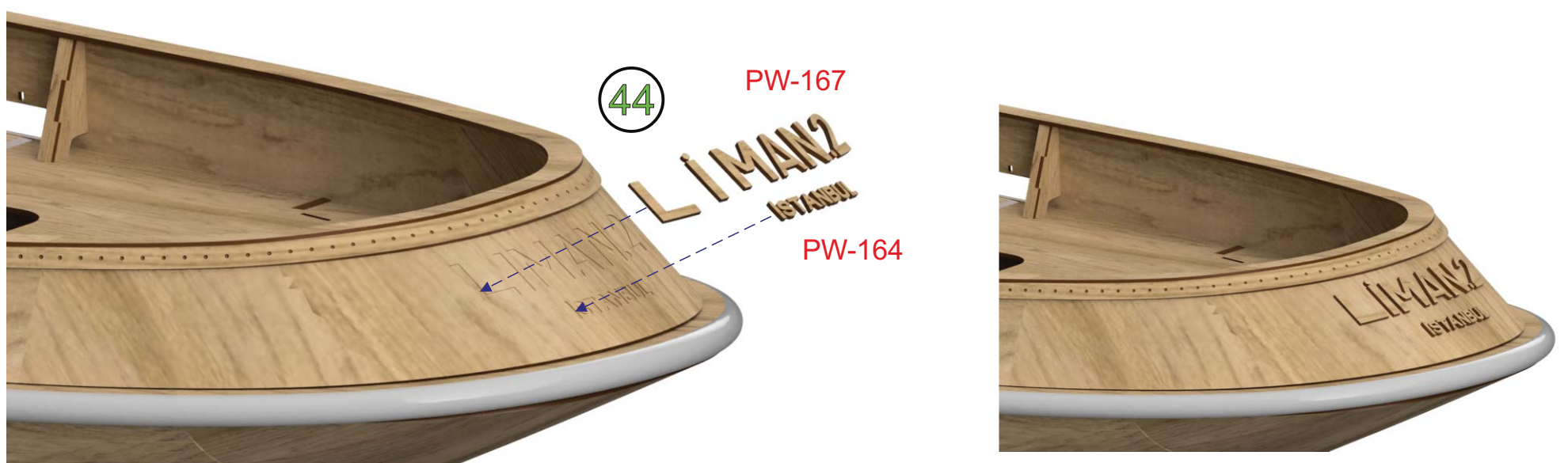

44

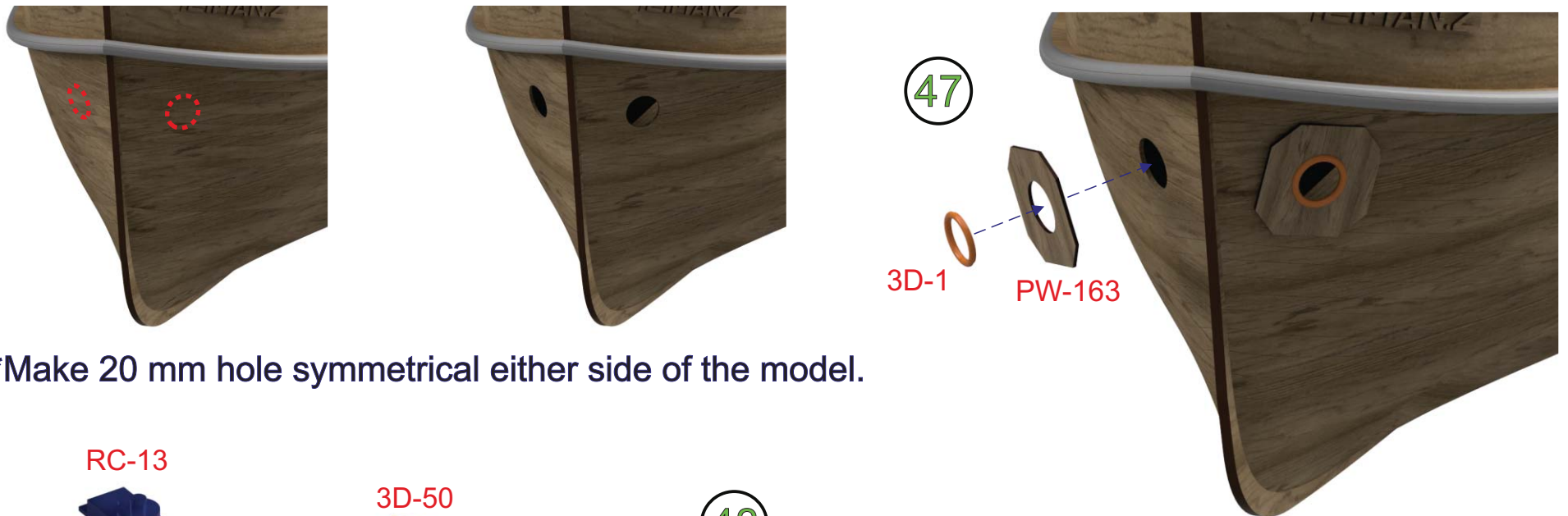
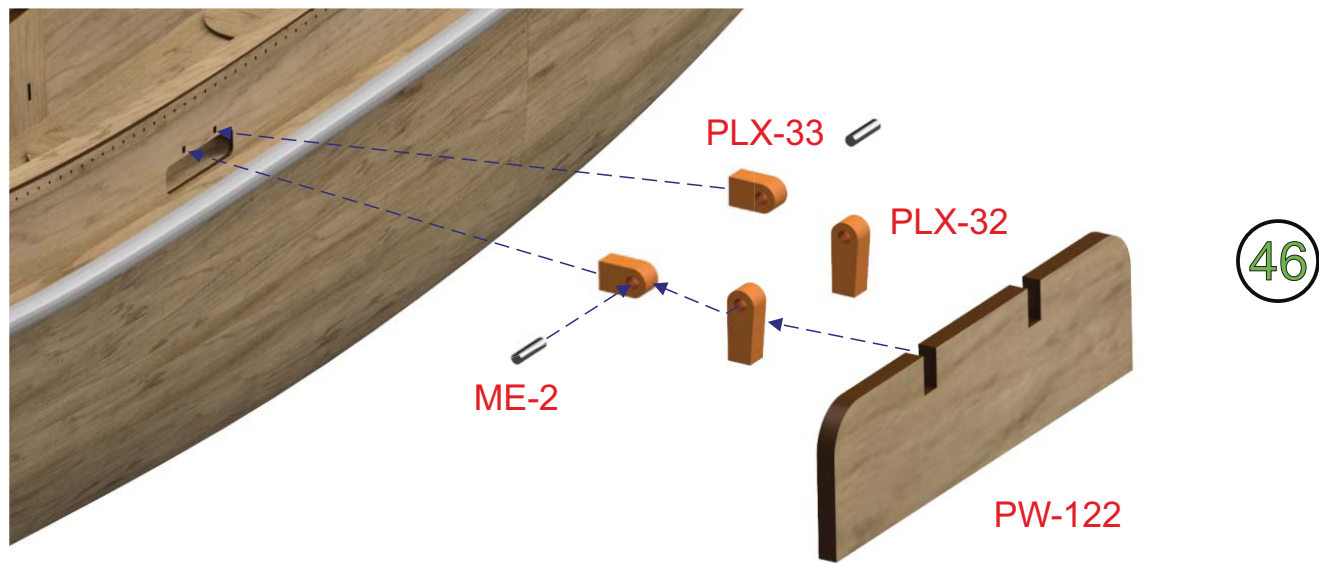
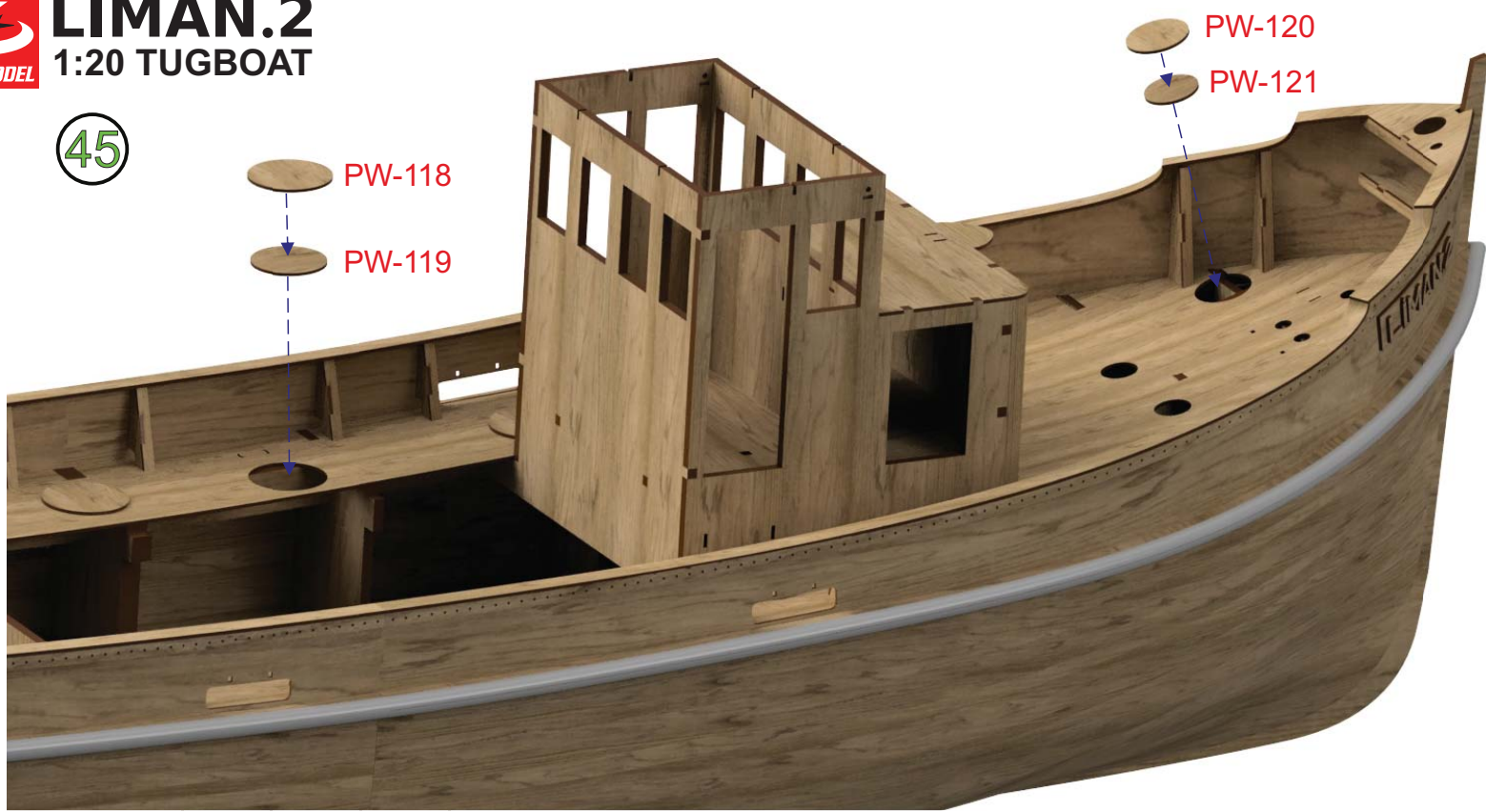

*Make 20 mm hole symmetrical either side of the model.

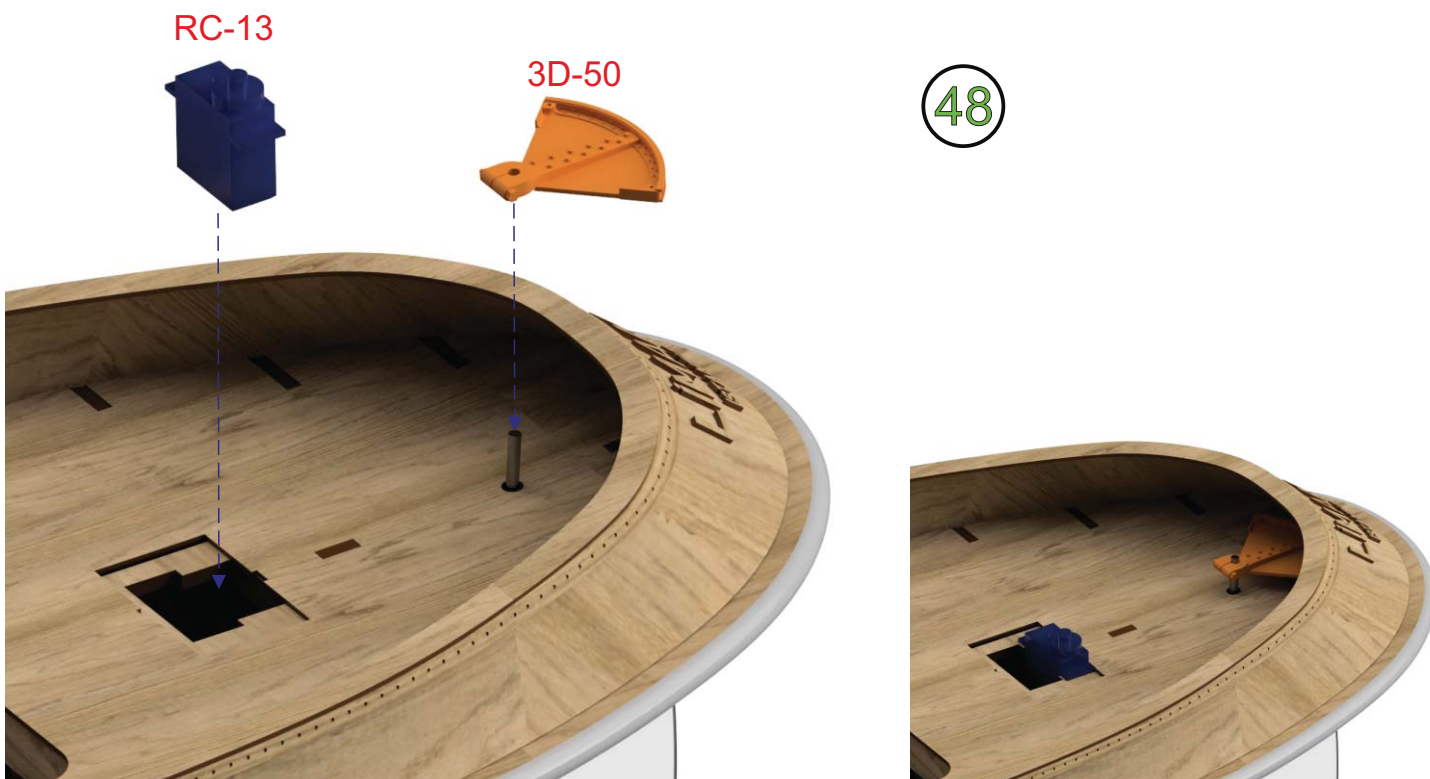

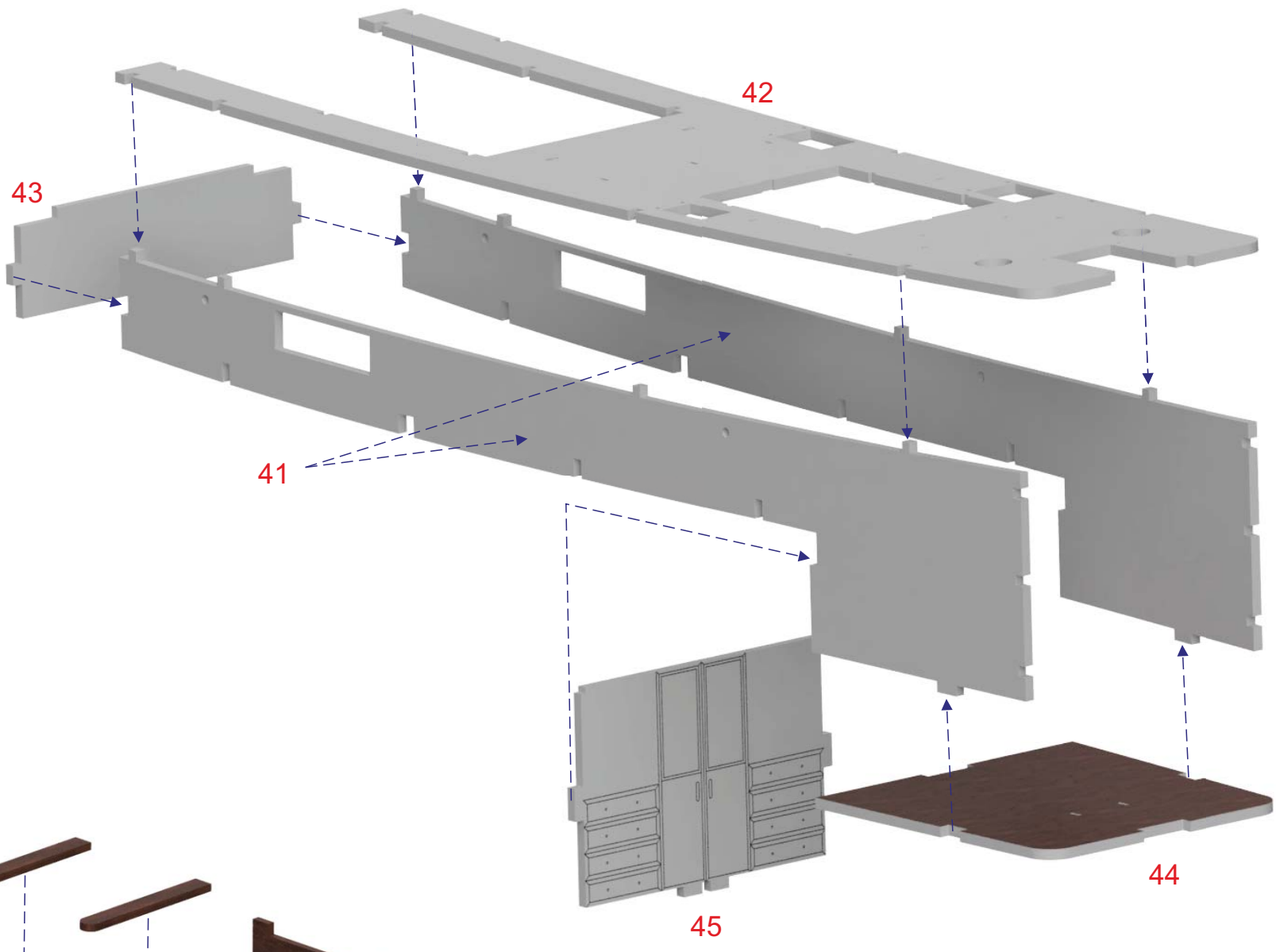

49

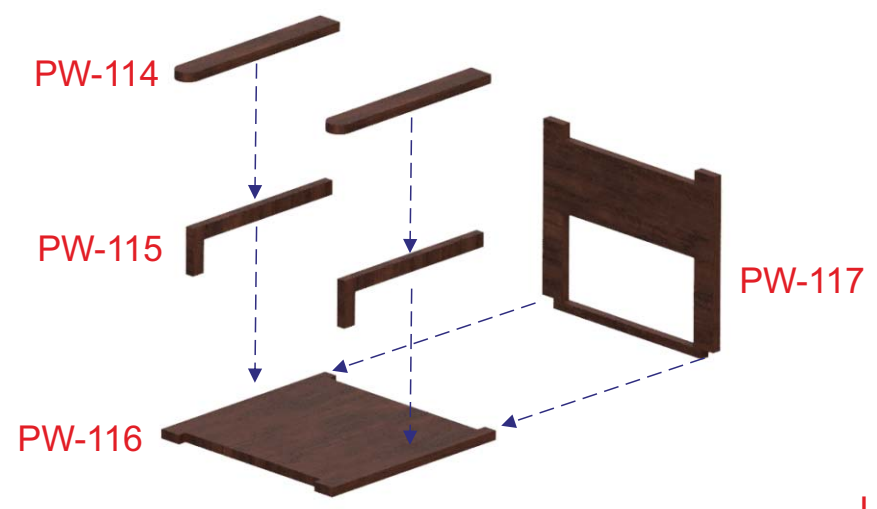

50

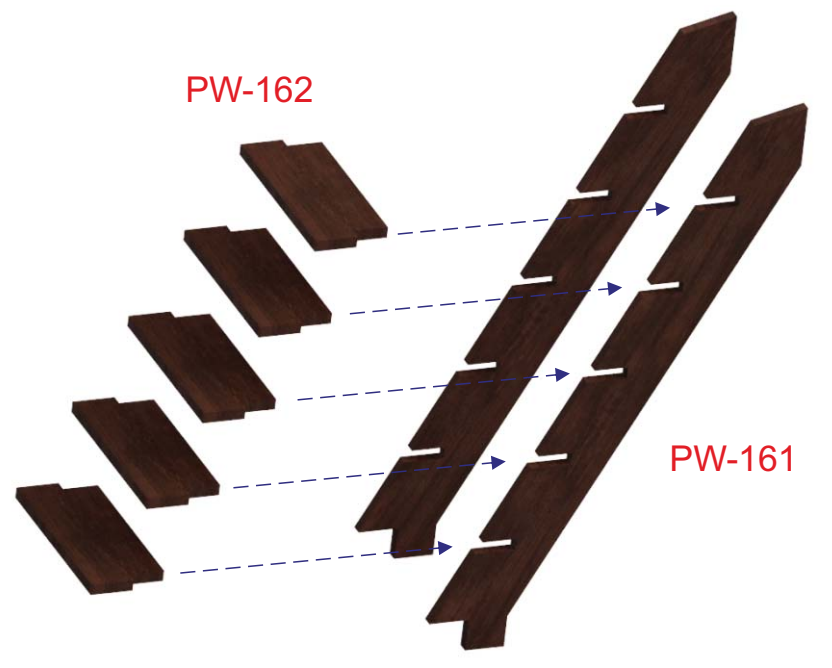
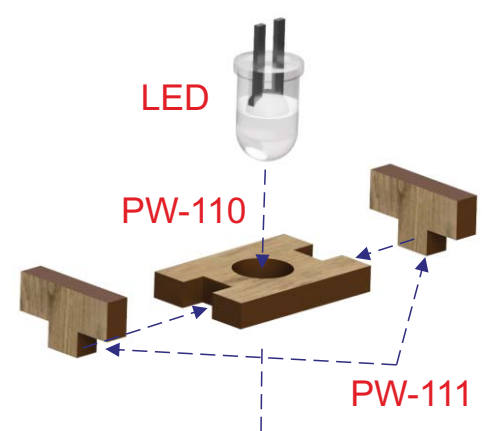
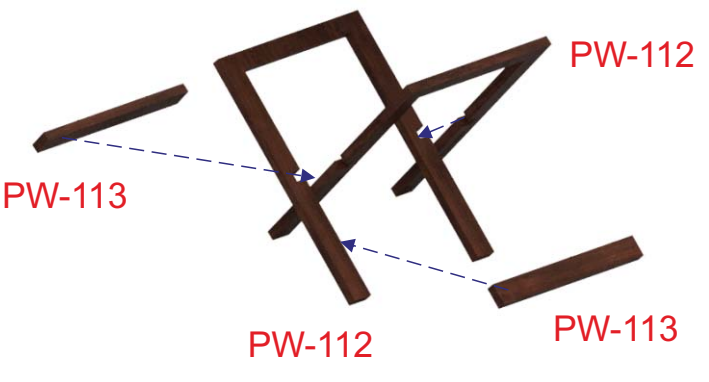

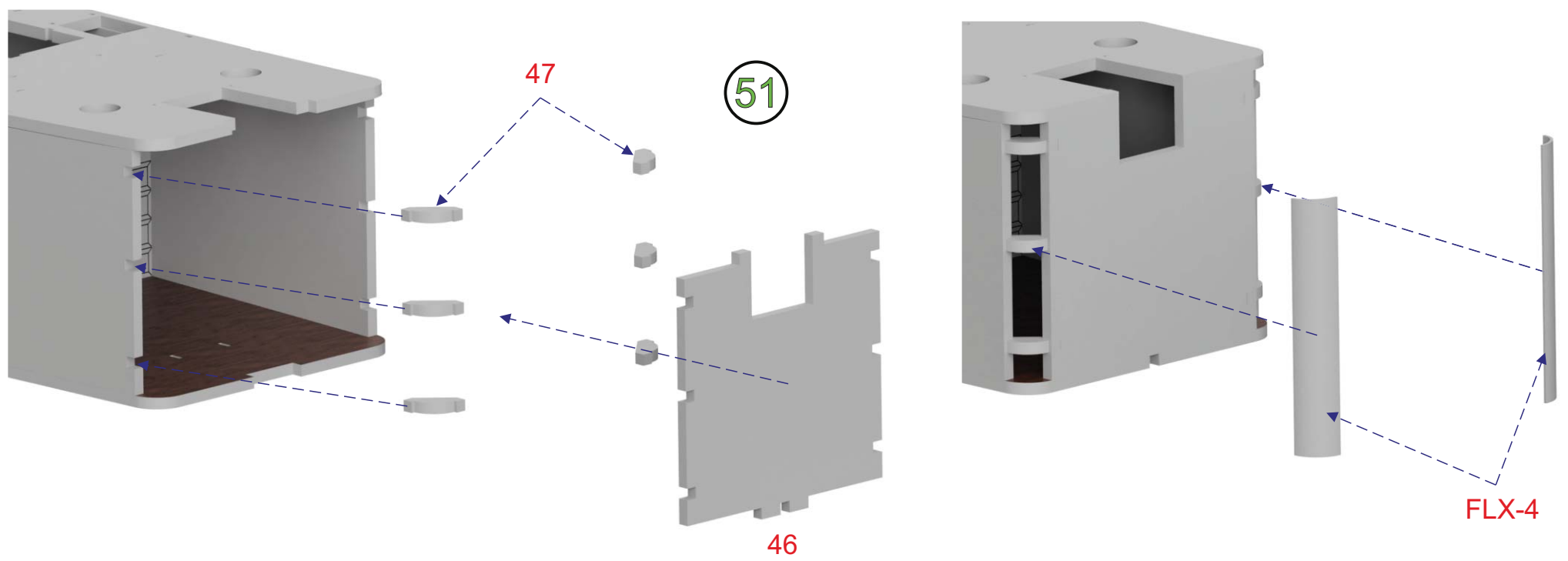

*Attach flexible parts as shaping carefully after keeping in a water container for 15-20 minutes.

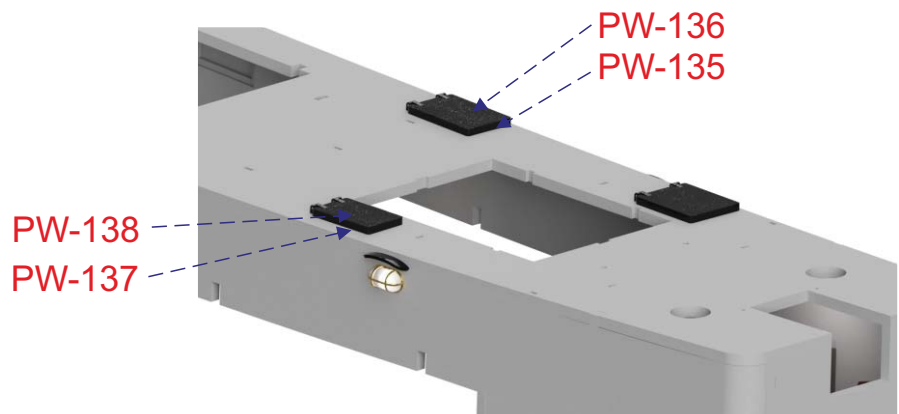
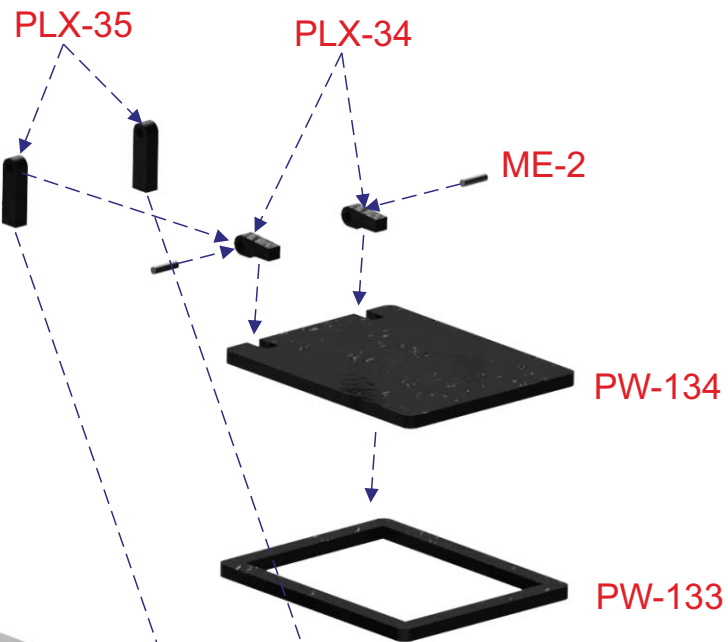
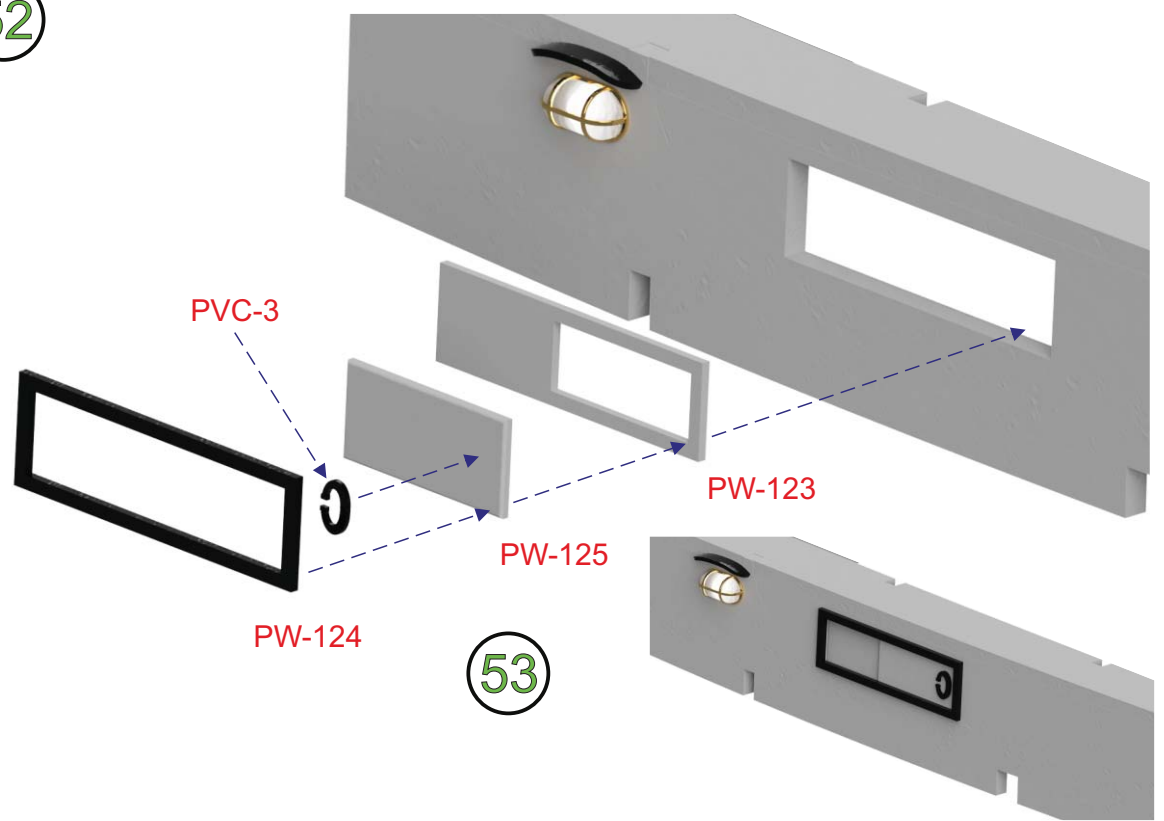
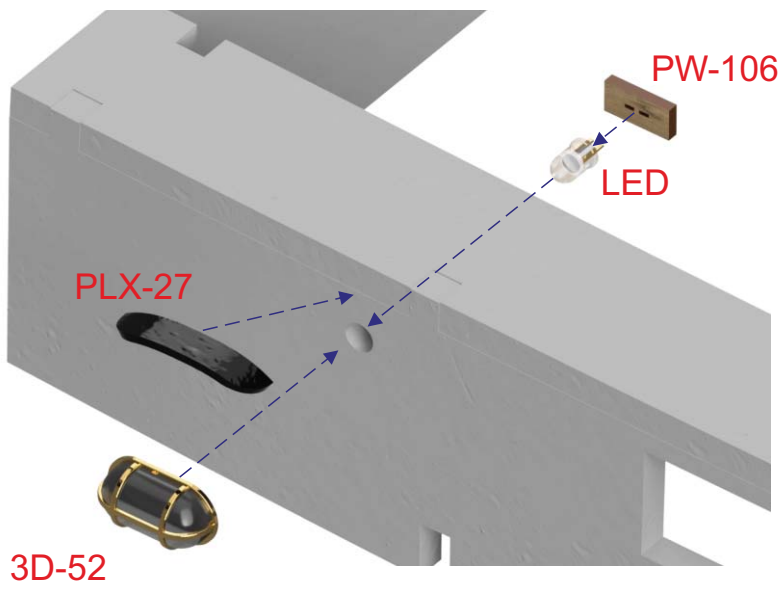

PLX-23

PVC-3

55

PW-142

PW-143

PW-139

PW-141

PW-140

PW-146

PW-144

PW-145

3D-67

M-3

PLX-25

PLX-28

3D-55

PW-156

3D-69

3D-29

PW-157-R

PLX-5

56

PW-157-L

57



58



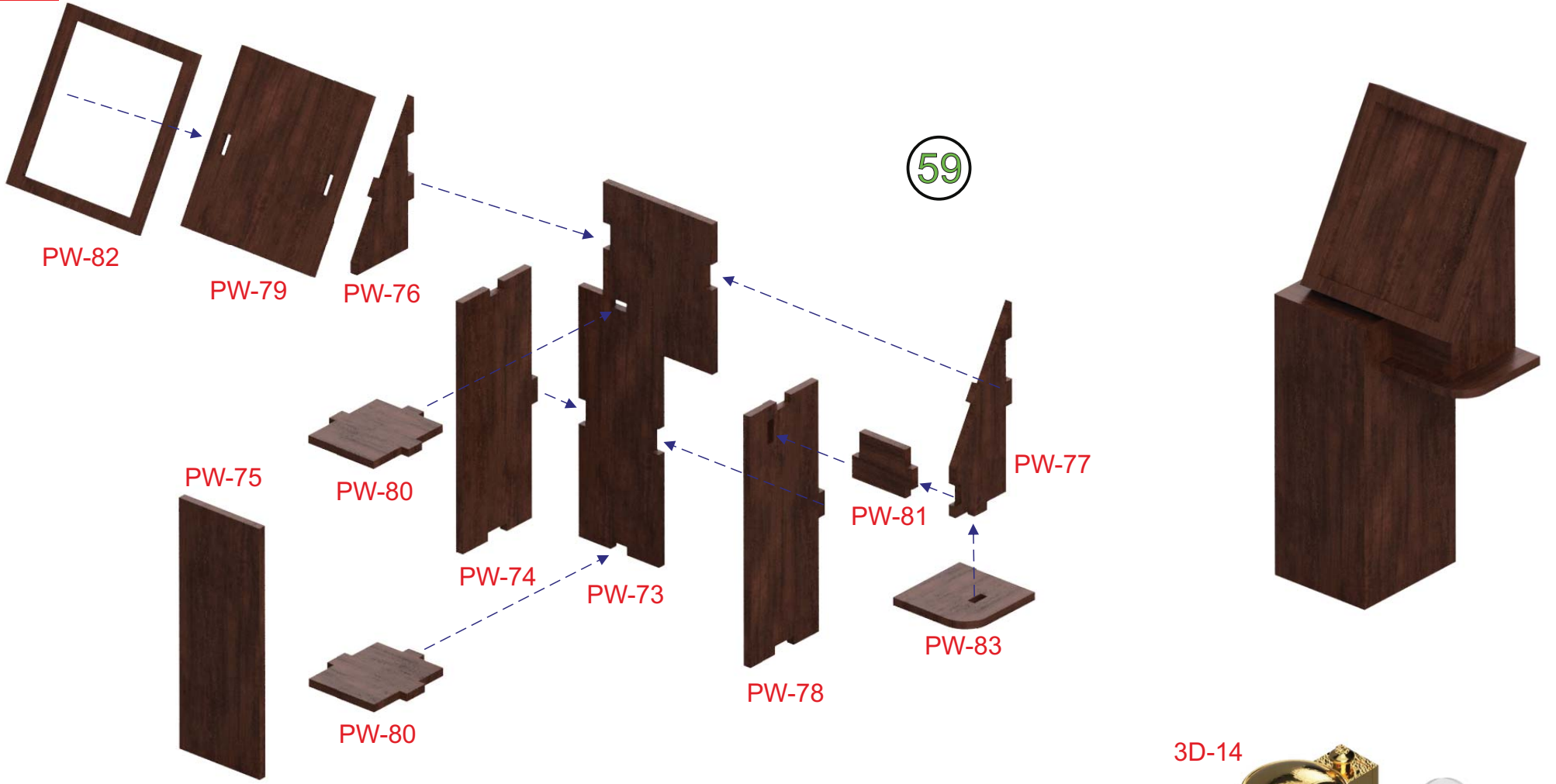

*Glue carefully together parts No:19 and No:20.
*Care of not dropping glue on No:18.

60

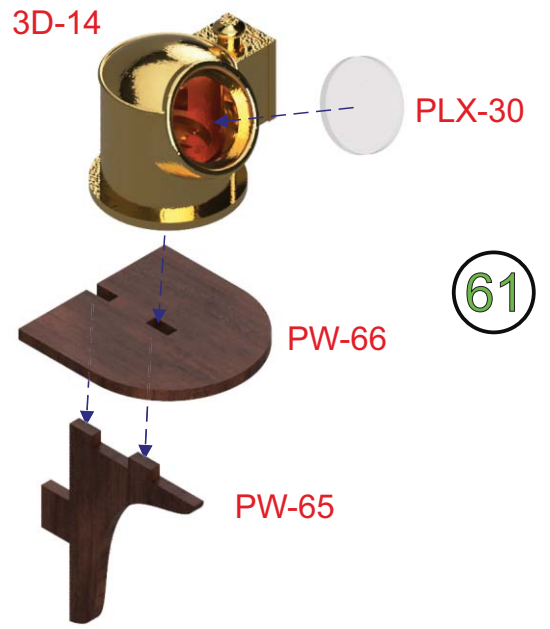

61

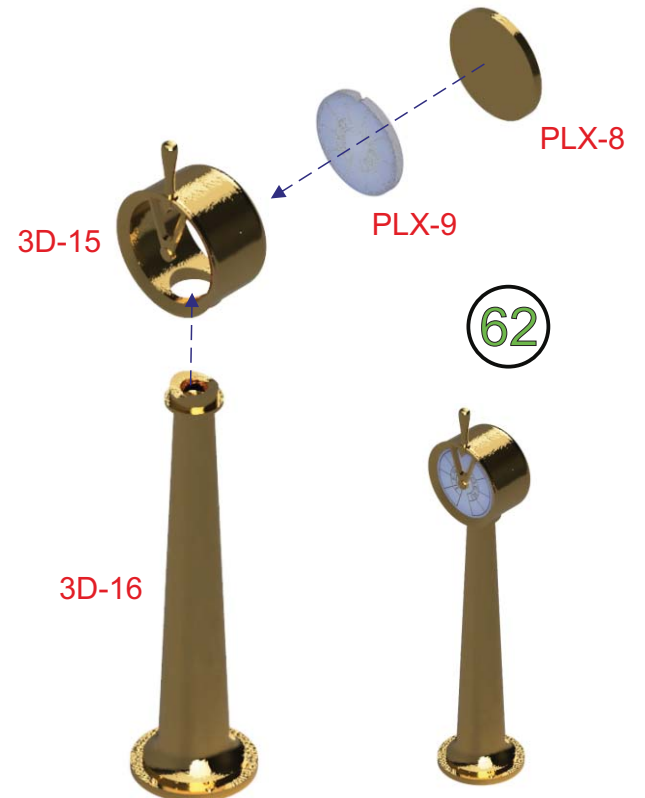
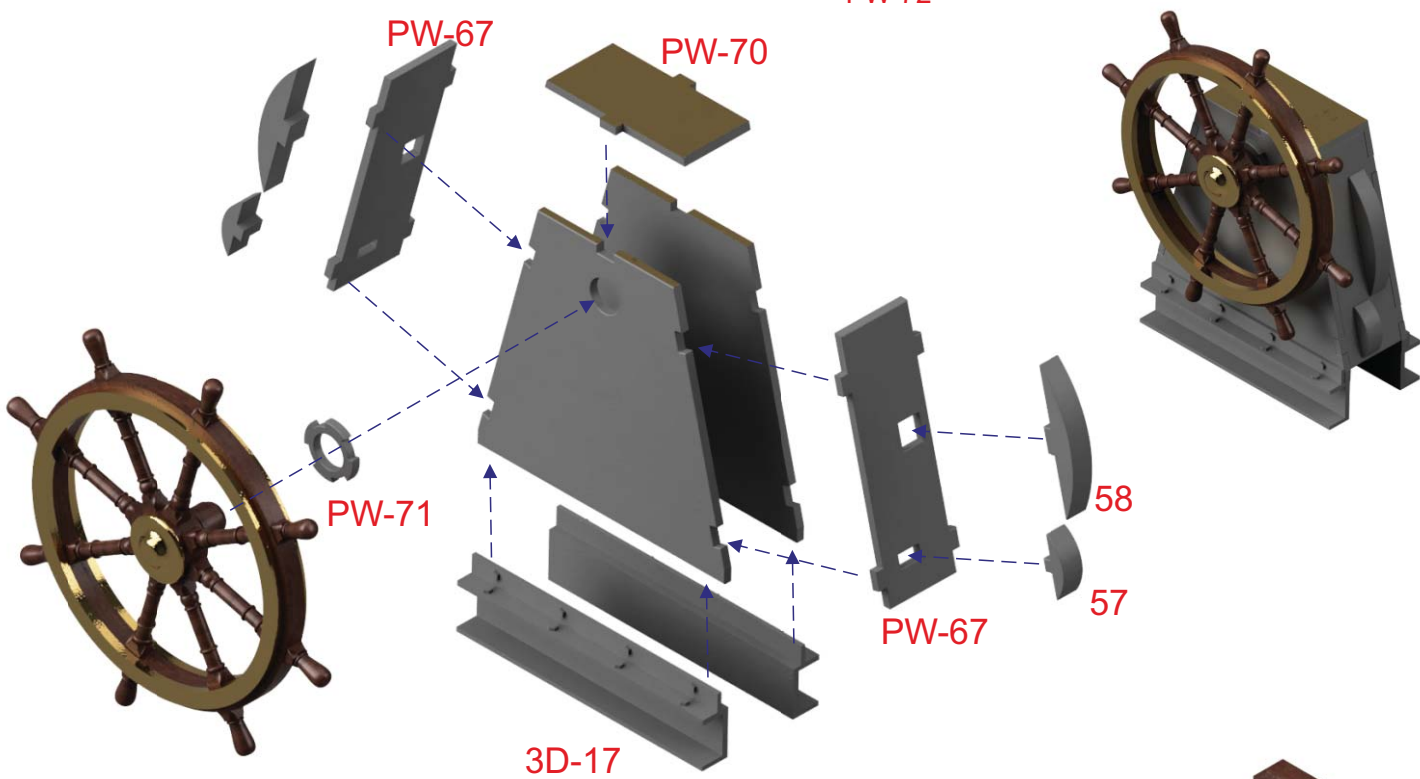

62

63

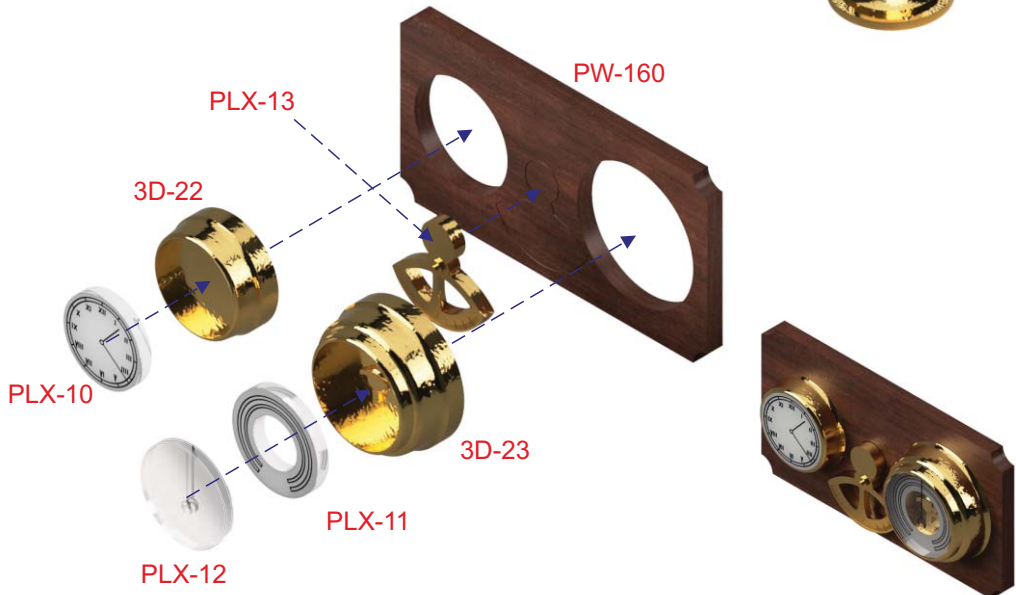

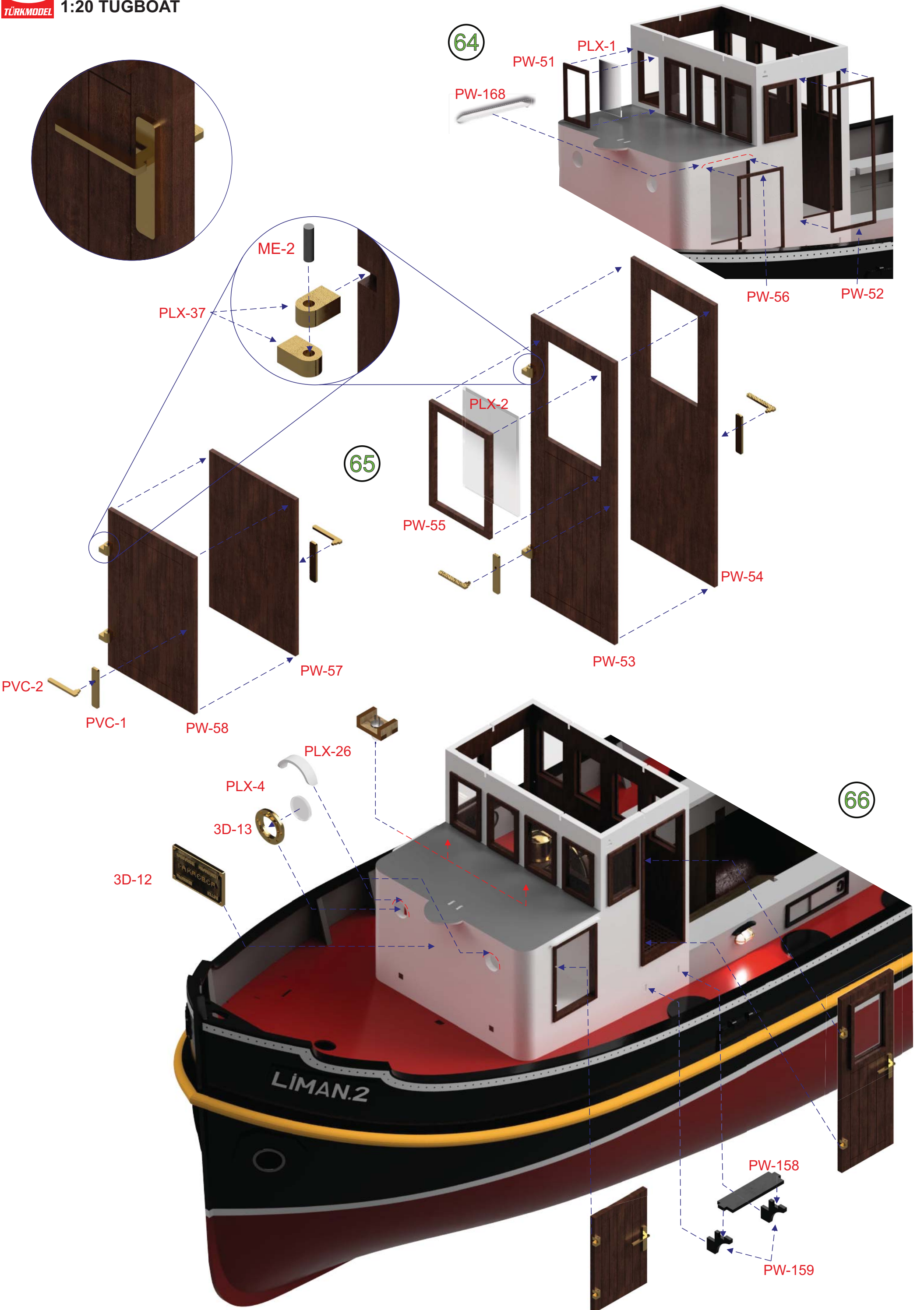

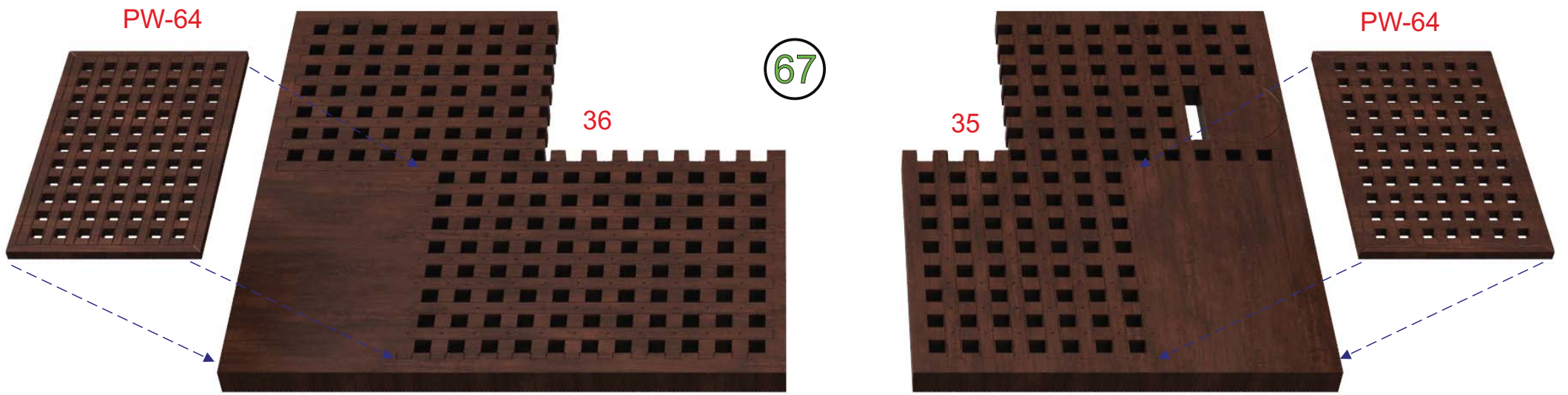
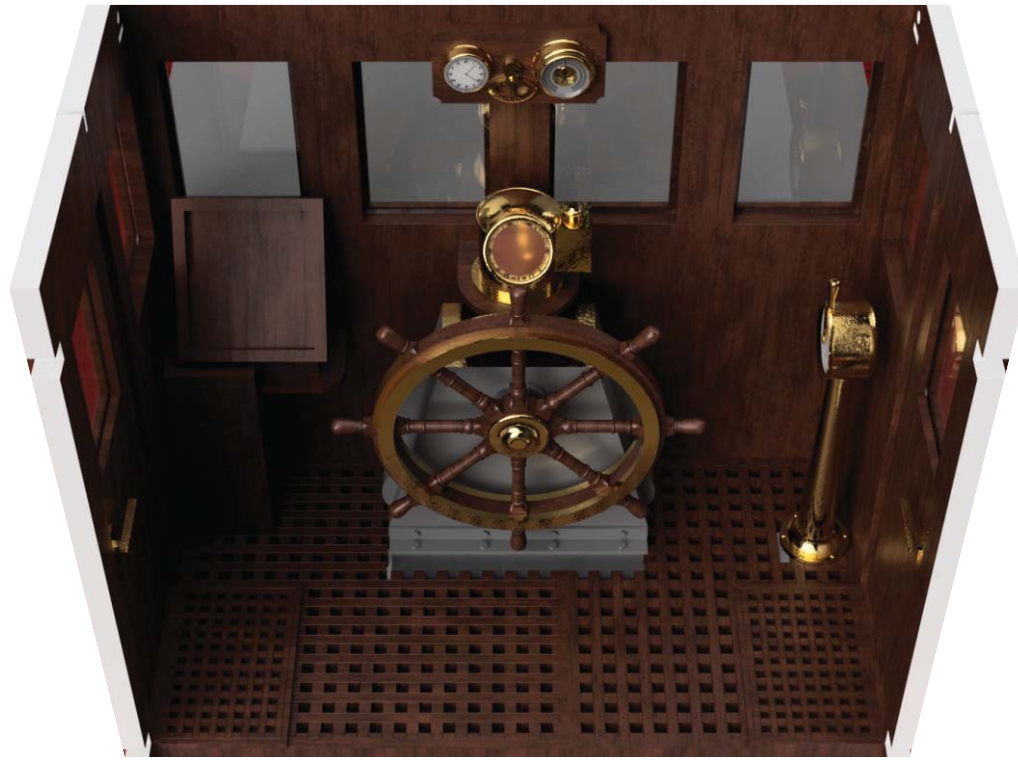

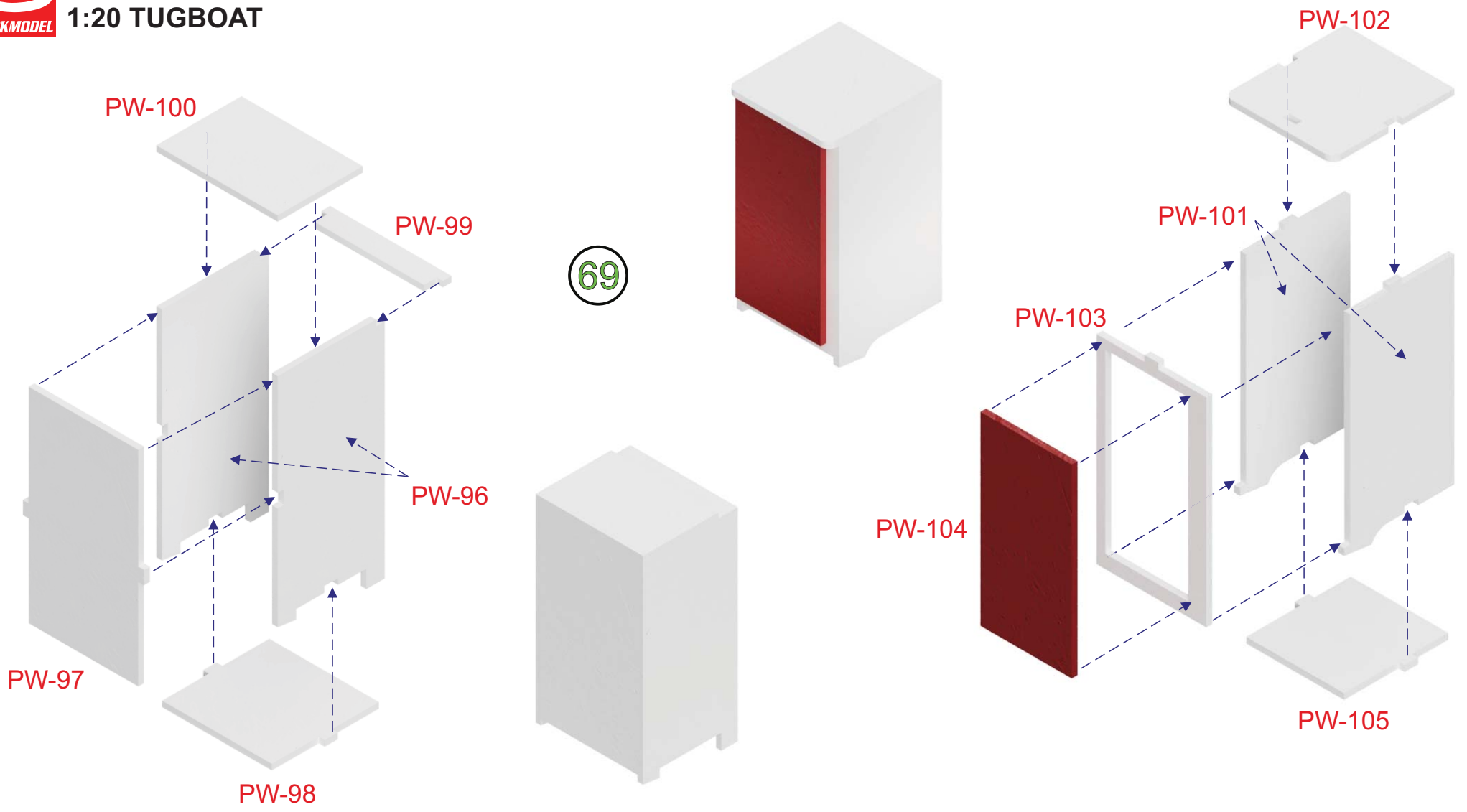

*Sand the parts adaptly.

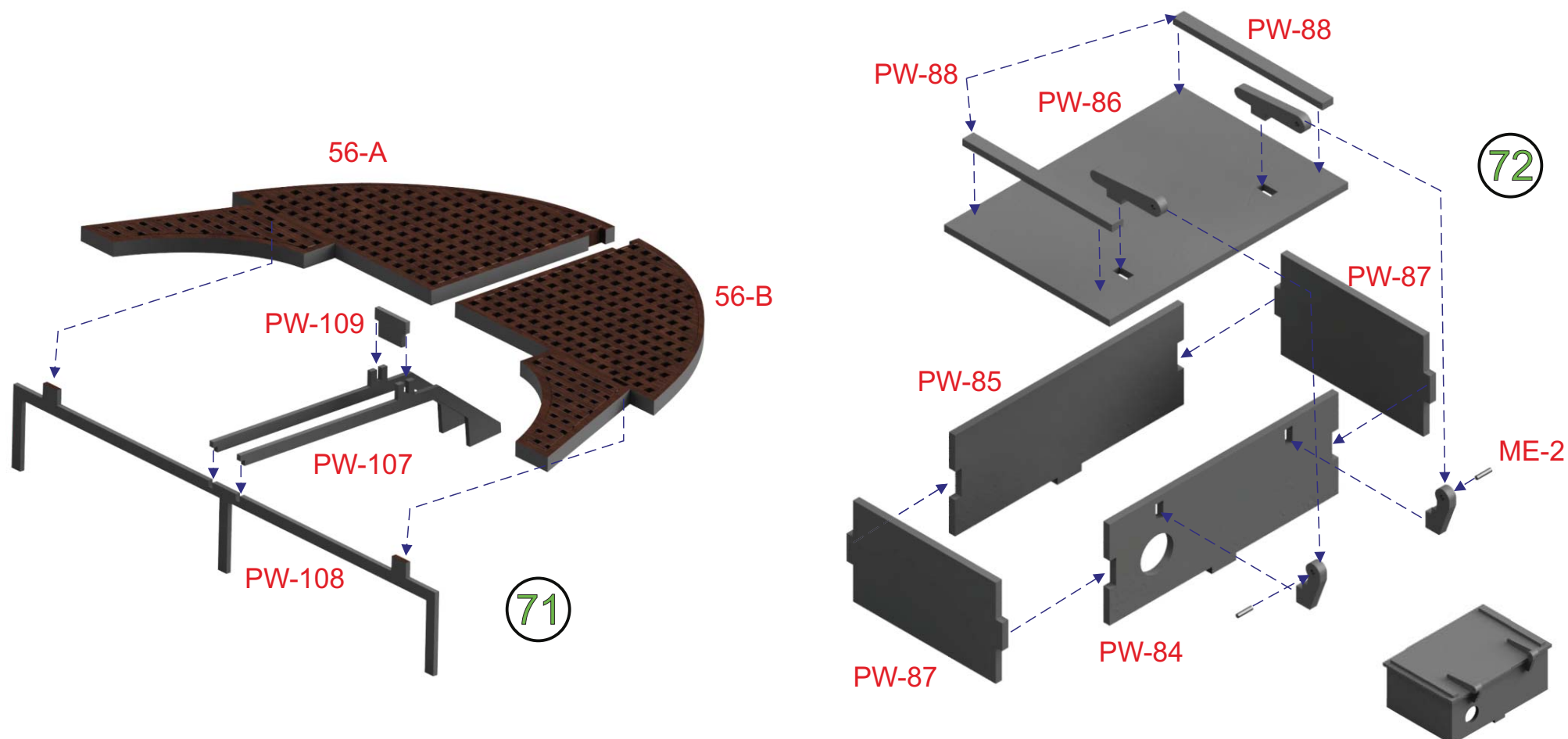
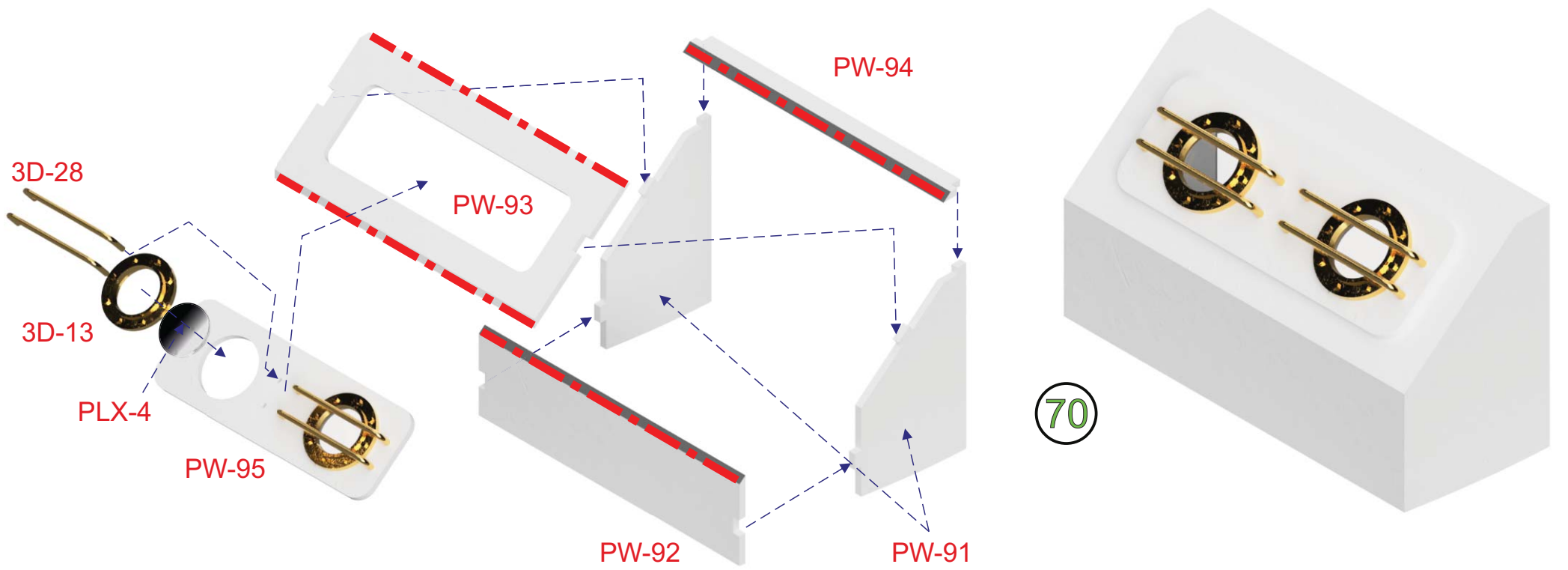

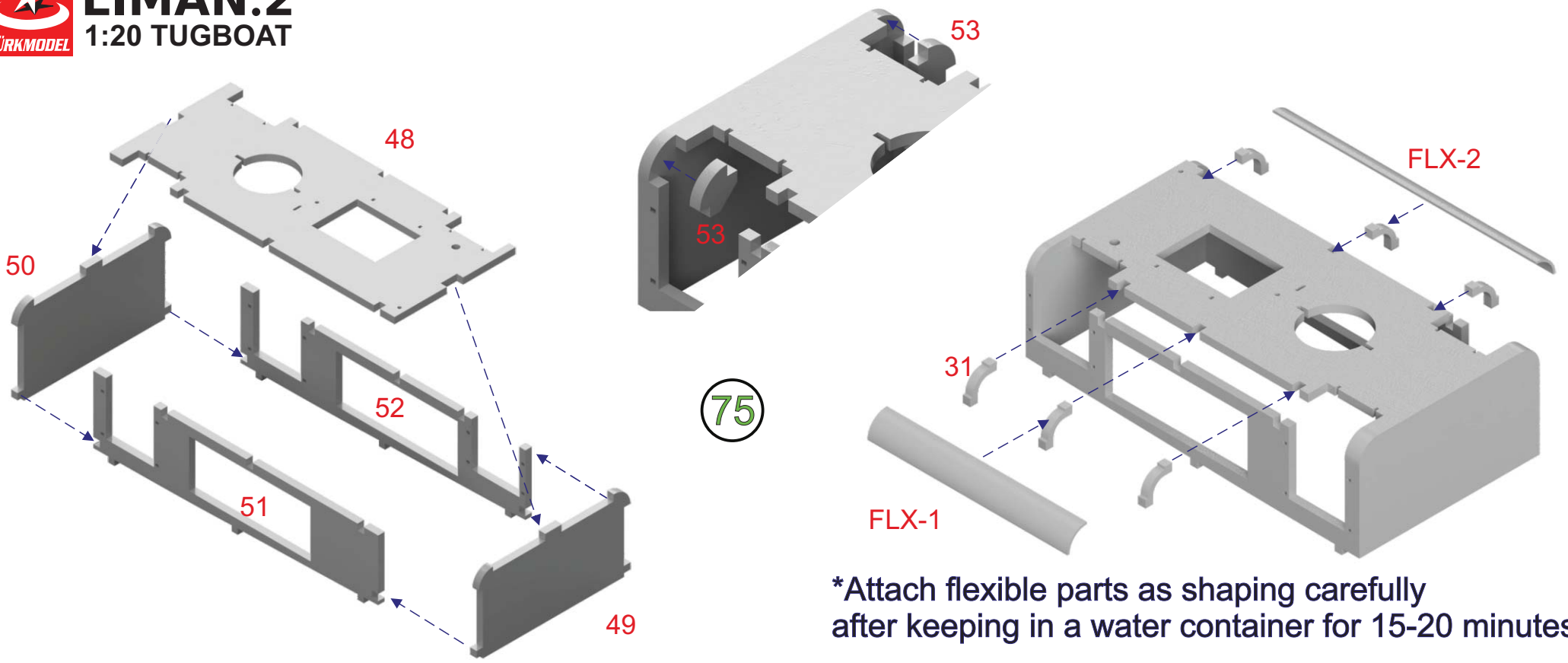

*Shape flexible parts carefully after keeping in a water container for 15-20 minutes.

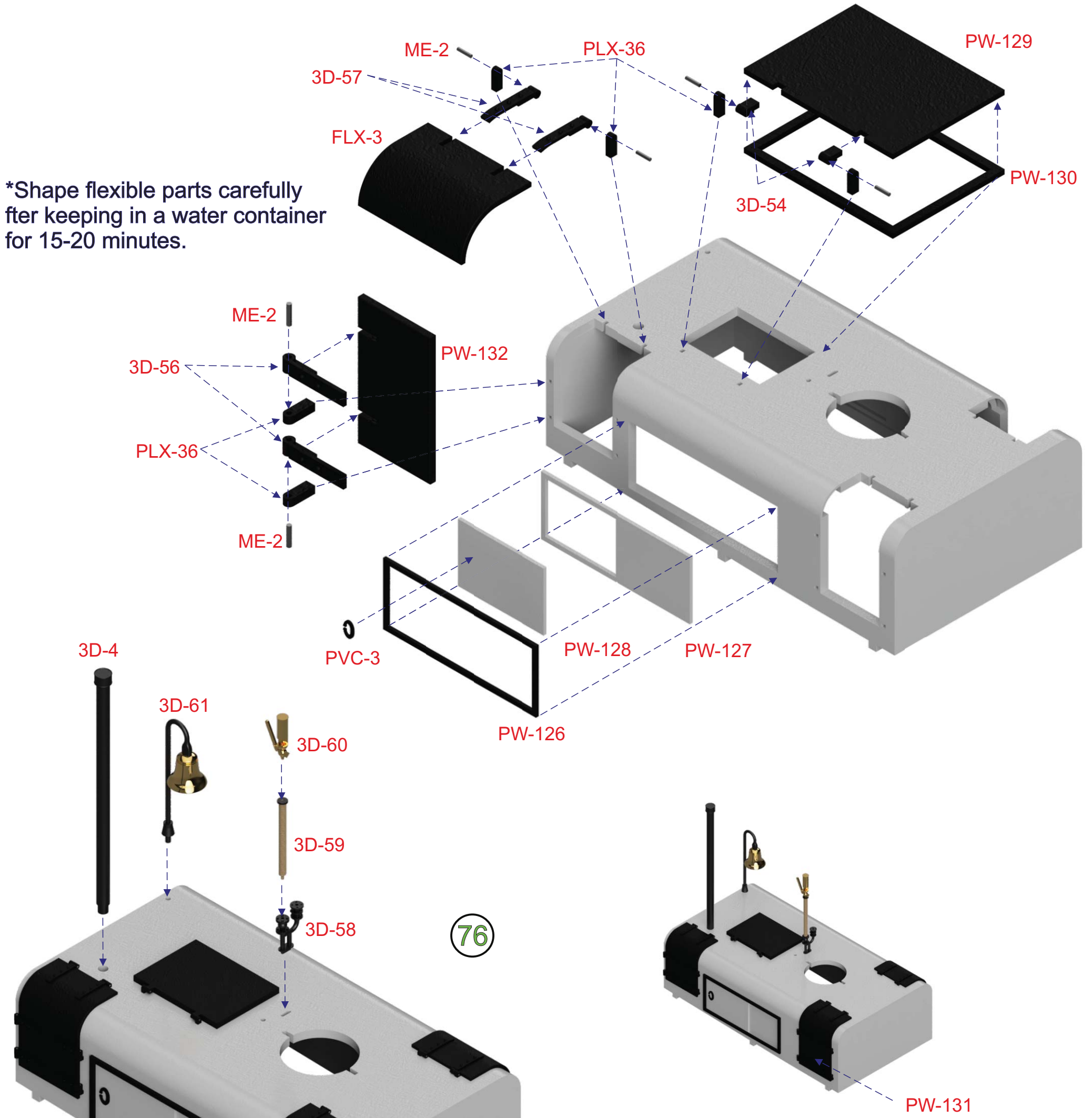

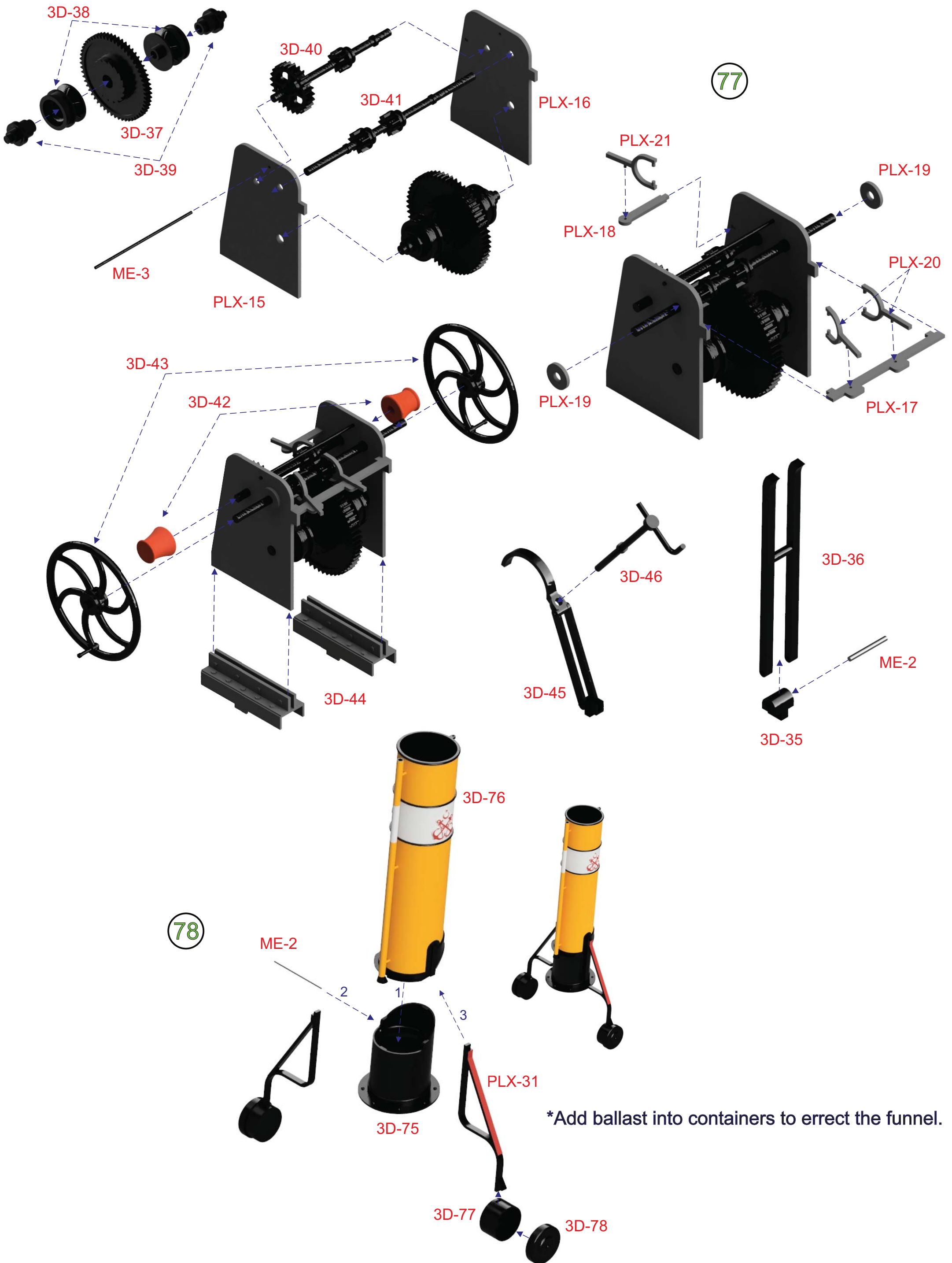

79

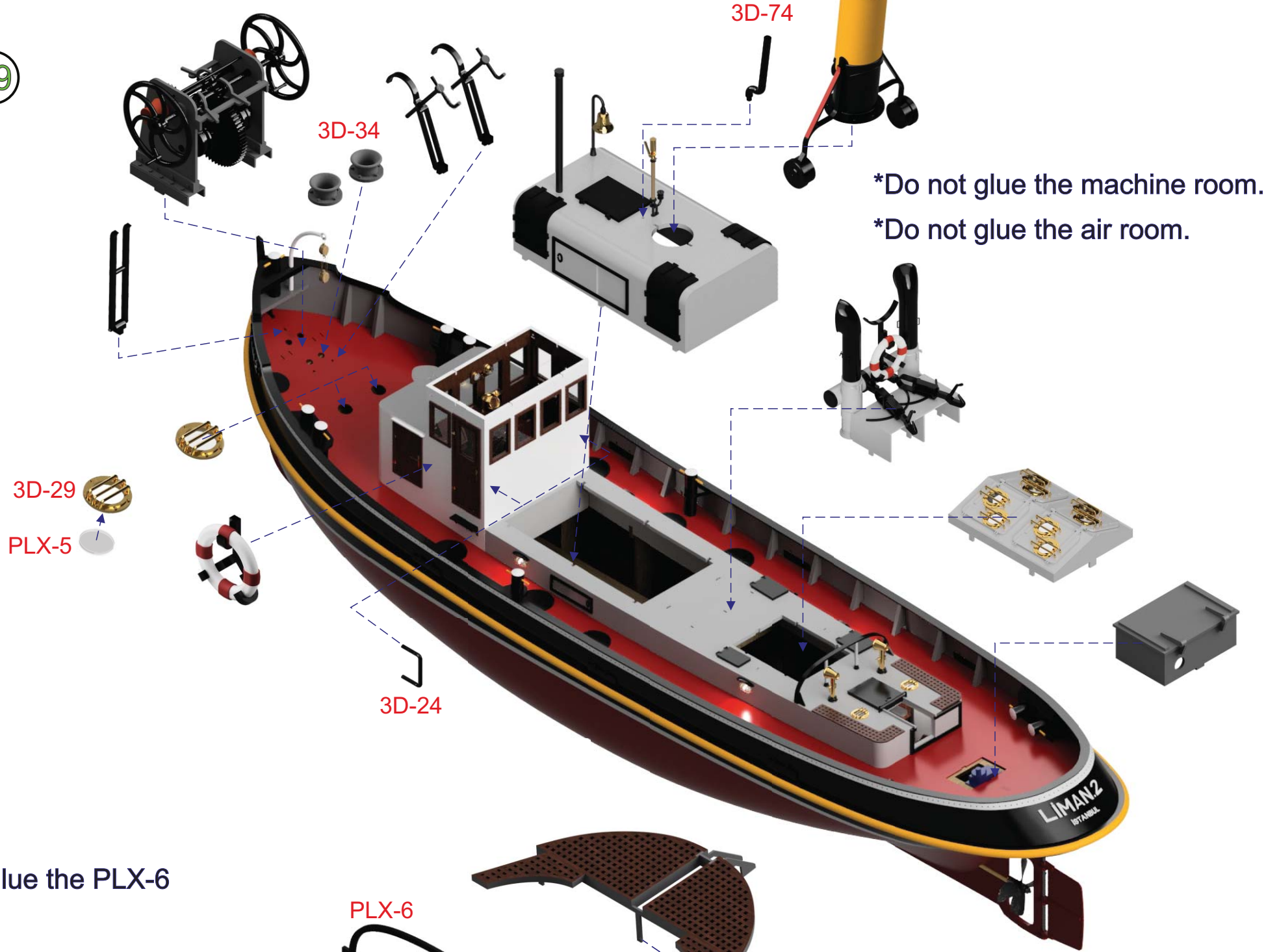

*Do not glue the PLX-6

80

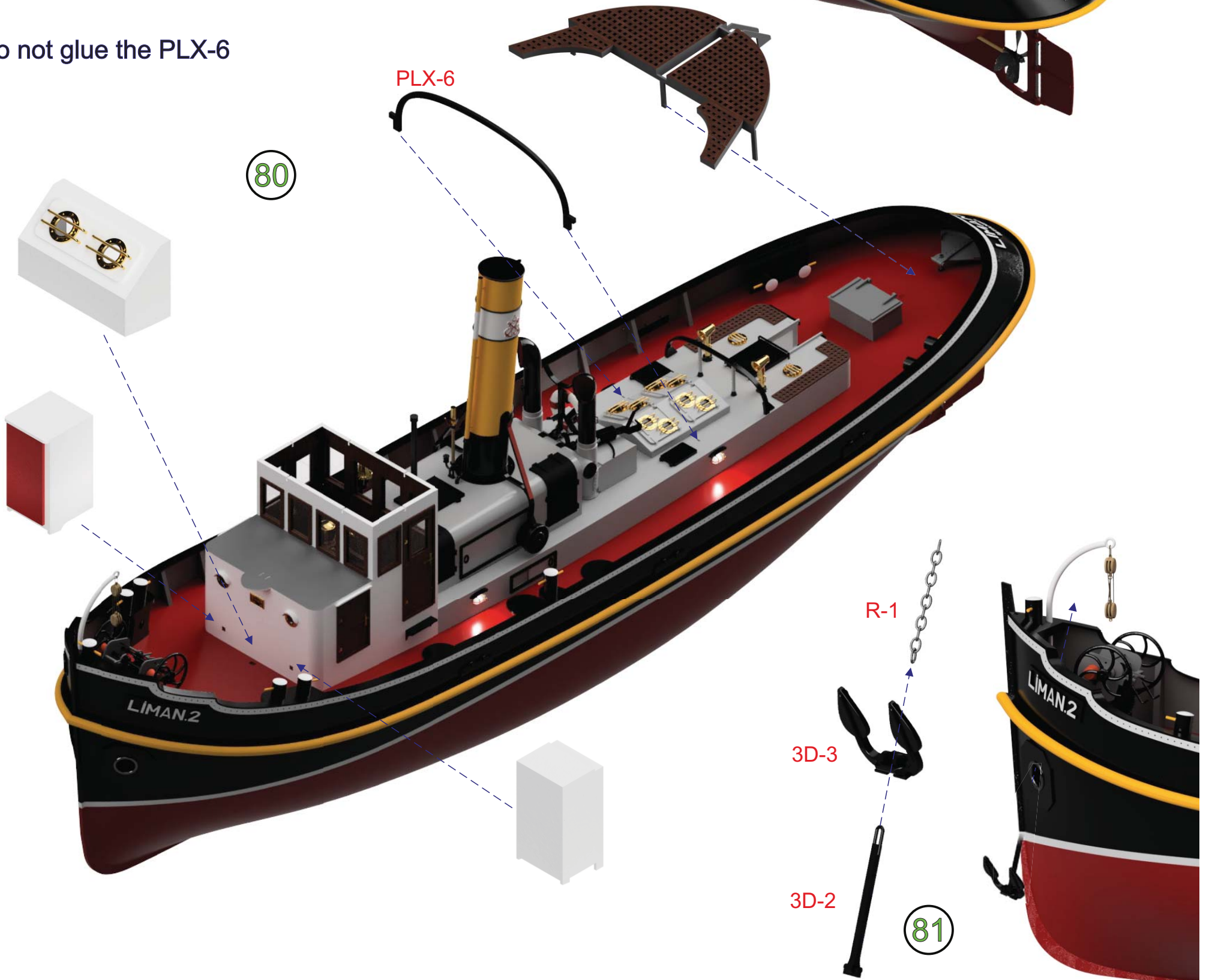

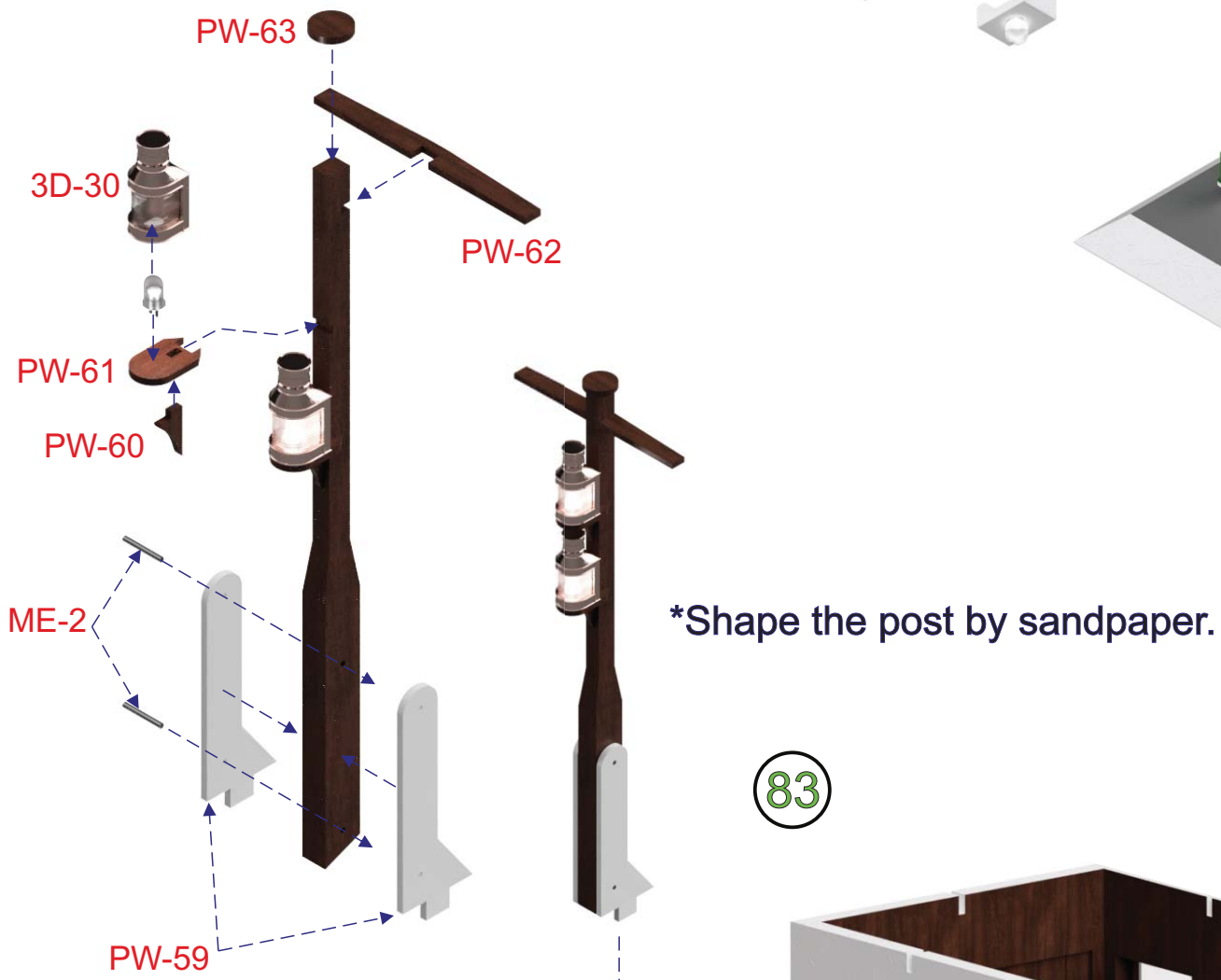
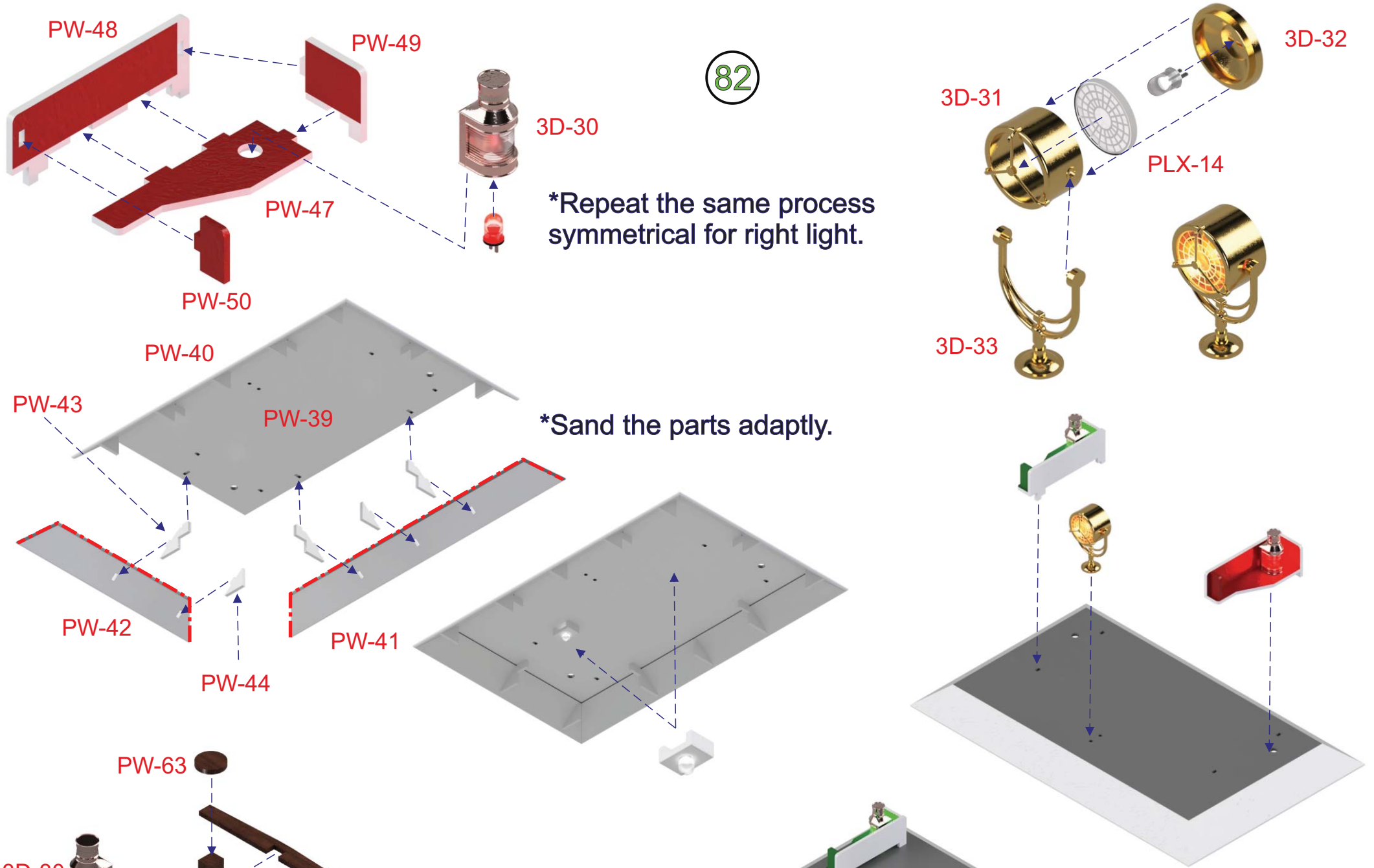

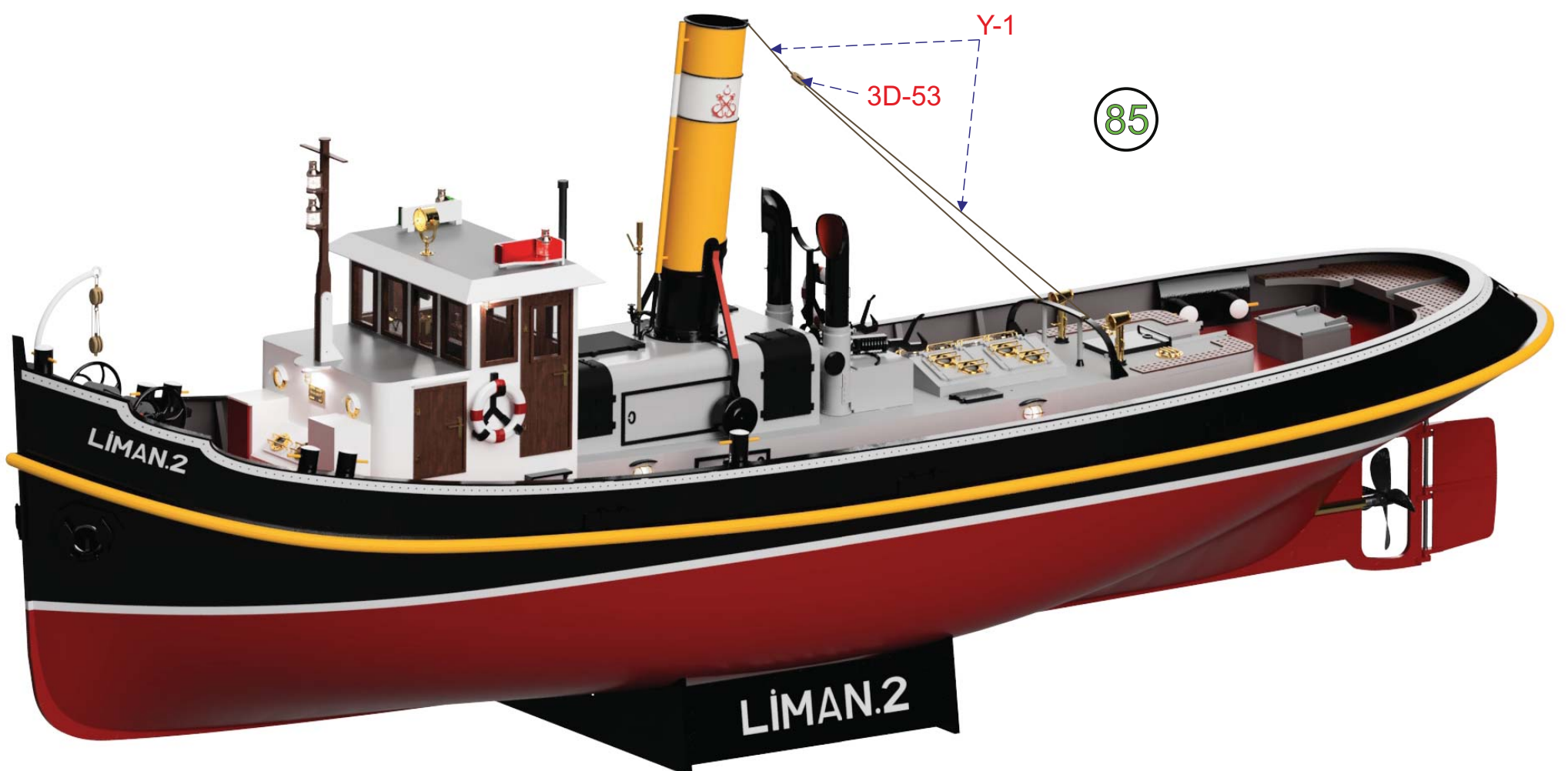
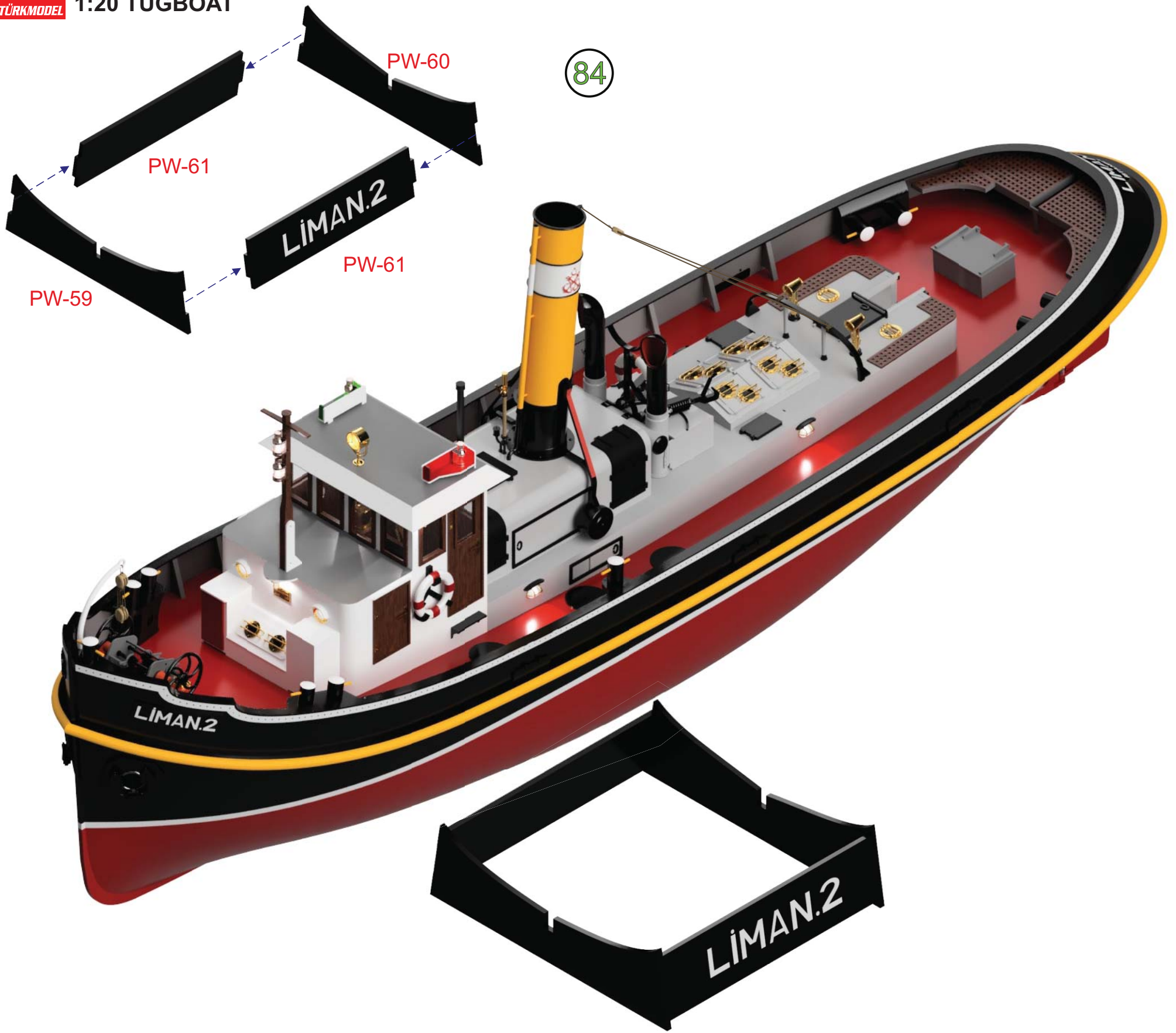

LED SET-UP

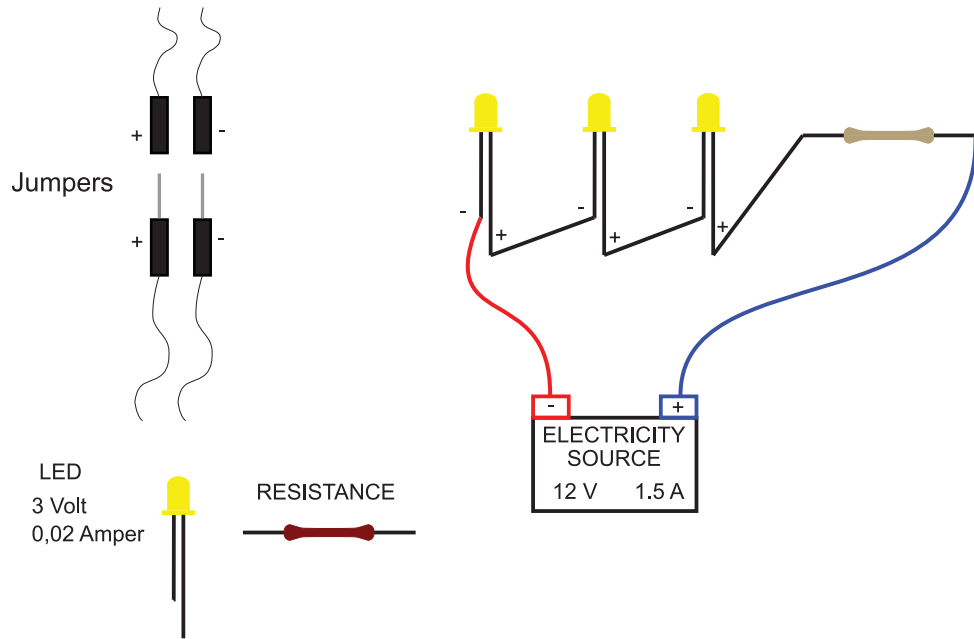

You will find out how to set lights up in this page. The first rule is each 3 leds connected serial. So, the light sets exist bunch of 3 serials in every deck. Cooper cable is isolated, so when you set it, sand or fire the tips to unisolate. The tip of the resistance is unimportant. Any tip can be connected to the serial leds.

Wherever you would like to put a led, penetrate 3 mm the led platform and place the led into. Then glue the led there but do not use over the glue, just tiny.

Test the leds on every stage If they work properly. If the leds are blinking, the energy source's amper is not enough. If there is no light at all, then check cables these might not be unisolated well or disconnected.

Connect the cables and the other components soldering. If you are not expert on soldering, get and support from an expert.

Though the cooper wire is unisolated, it might lose its feature by the time. If they are cross anywhere, put a small separator to keep it away from short circuit.

By the time, some leds might be died. In this situation, test the serial that covers that led and resistance. If you do not have a equipment to test, then just swap those 3 serial leds and resistance with new ones.

Collect the deck cables into a tip of a jack. The other tip of jack should connected to the energy source. You do this for every deck it might be needed to remove. It is going to make easier to disattach the decks. Easily you will plug off the led connections to make free the decks.

Watch out collecting (+) and (-) will be right.

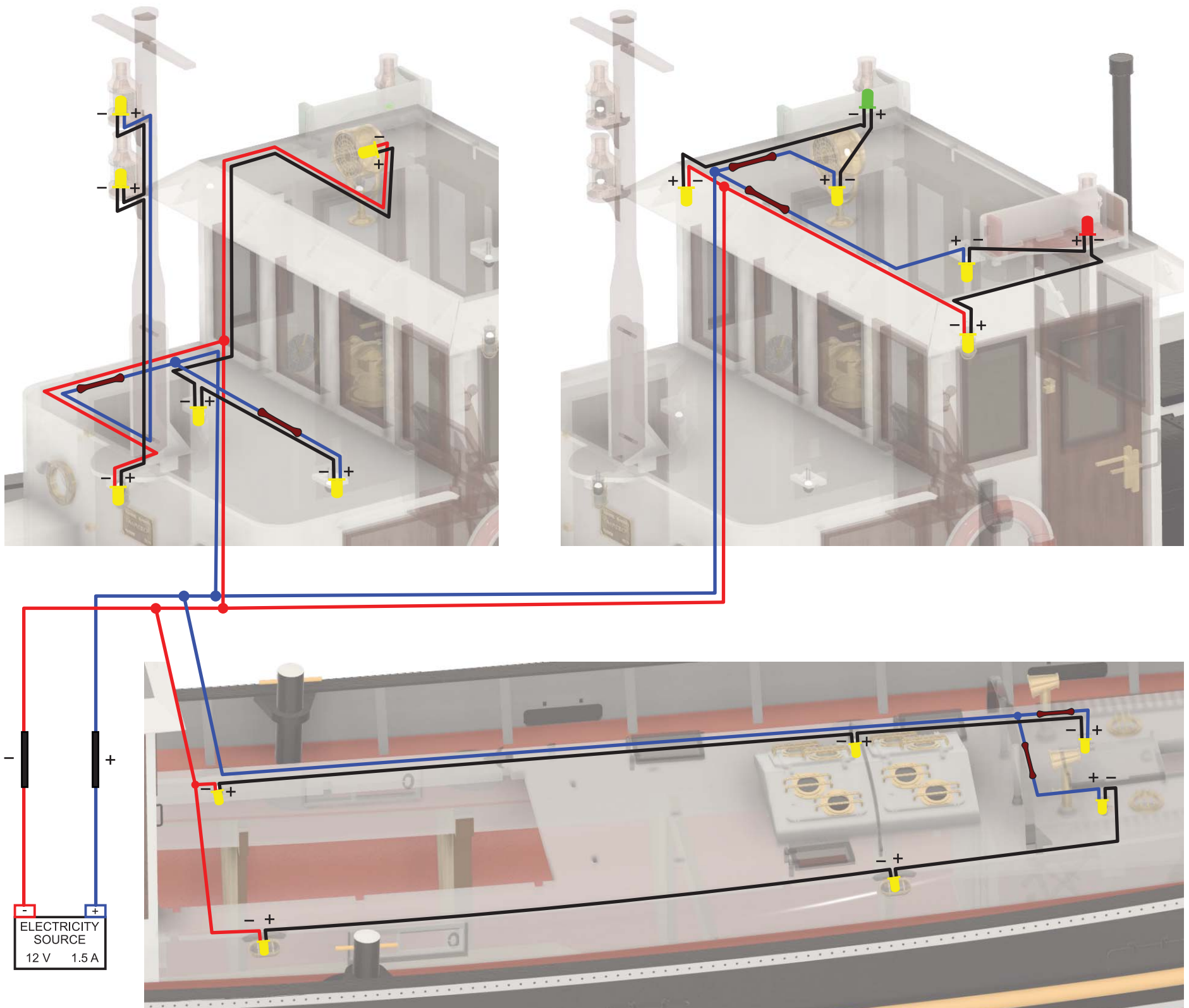

R/C SET-UP

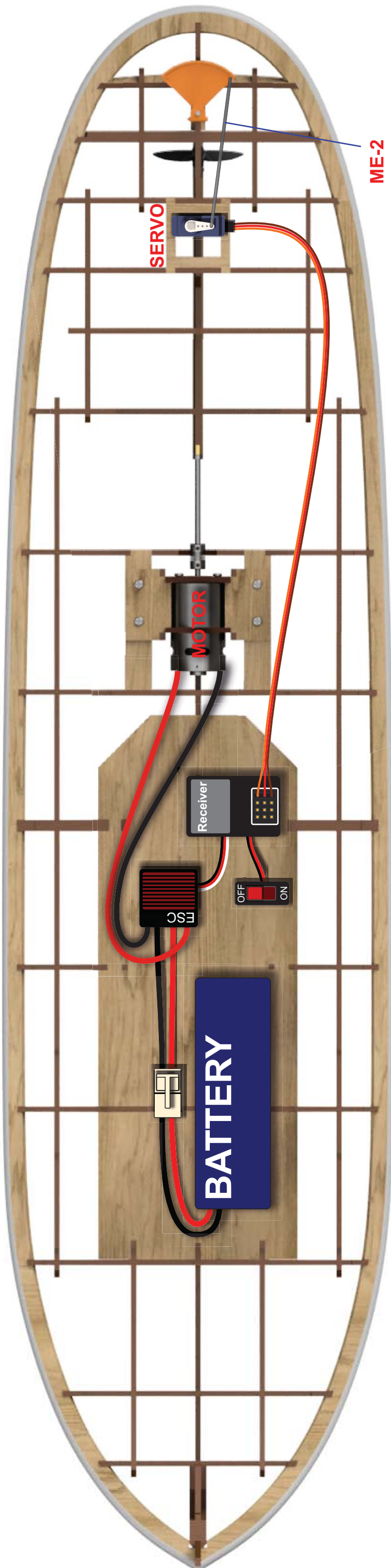

- ❖ Please read the instructions carefully before you start to build your model. Take notes if needed. So, you may find out the materials and the tools those you need.
- ❖ Use model knife to take out the parts the plywood sheets. Do not take them out with hand!
- ❖ Change of temperature effects on plywoods quickly. So that, do not release the plywoods. Keep them on a flat surface by putting weight on them.
- ❖ You may stick together the wooden parts easily if you sand the brown areas caused by laser with sand paper.
- ❖ You should use super glue and white glue to stick together the wooden parts and use the super glue for metal parts.
- ❖ Building the keel of your model, before stick the frames, be sure the frames properly seated on the keel. Otherwise you can't build the body of the model rightly. Exactly be sure that left and right side of the frames are compatible and symmetrical.
- ❖ After building the keel of your model, before the covering, you should test the frame edges by a cover strip. You should sand with a piece of sandpaper the frame edges at the right degree to touch the strips on to the surface exactly. The curves are mostly the front and back side of the body.
- ❖ You should keep the strip tips in the bowl filled with water approximately one hour. So that you may curve the strips on the curves easily these are mostly at the end and the front of the hull.
- ❖ You should cover the strip starting from the top for each side symmetrically.
- ❖ You should cut the upper side of the strip when overlap occurs especially at the front curve of the body.
- ❖ To make equal the surface of the body that caused by planking, you should sand with a piece of sandpaper (Firstly you should use thick sandpaper, then you can apply thin sandpaper), . You should fill the gaps after this processing. You may use leftover strips for wide gaps and model putty for small gaps.
- ❖ If you don't want to appear wooden tissue of the body of your model body; first, apply filler undercoat then sand with a thin sandpaper to make it ready to apply putty. Apply putty whole body and sandpaper again. Apply one more coat filler undercoat and sandpaper. You should not use very thick sandpaper to sand the putty and filler undercoat. You should repeat this process until you get the results as you want. You should apply undercoat paint to find out if any mistake appears at the body. The body gets ready for painting after these applications. You may use model brushes for filler coating. In order to understand whether the materials (such paint, filler, undercoat, varnish, etc.) are compatible with each other, you should test on the unnecessary parts.
- ❖ Some of the model's logo, name or the number are produced from decal paper. You should keep them in a bowl filled with warm water for two or three minutes. You should apply them to their places while releasing from their paper. You may attach easily If you apply gloss varnish to the place before applying the decals. You may apply matt, gloss or satin varnish after this application preferably.
- ❖ You should keep your model away from direct sunlight, heat and moist to avoid deformation in the course of time.

LİMAN 2 PART LİST

0	1	Keel front	4 mm	<i>Plywood</i>
00.	1	Keel back	4 mm	<i>Plywood</i>
00-B	1	Propeller keeper	4mm	<i>Plywood</i>
0	2	Keel locks	4mm	<i>Plywood</i>
00-C	2	Rudder axle house	4mm	<i>Plywood</i>
1...13	16	Frames	4 mm	<i>Plywood</i>
14	1	Platform	4 mm	<i>Plywood</i>
15...18	8	Frame locks	4 mm	<i>Plywood</i>
19	1	Deck support	4 mm	<i>Plywood</i>
20	2	Nose supports	4 mm	<i>Plywood</i>
21	1	Servo house	4 mm	<i>Plywood</i>
22-23	2	Engine house	4 mm	<i>Plywood</i>
24-25-26	6	Engine chassis parts	4 mm	<i>Plywood</i>
27-28-29	3	Wheelhouse wall	4 mm	<i>Plywood</i>
30	2	Wheelhouse side wall	4 mm	<i>Plywood</i>
31	12	Flexible plate support	4 mm	<i>Plywood</i>
32	8	Wheelhouse floor support	4 mm	<i>Plywood</i>
33-34	2	Wheelhouse floor parts	4 mm	<i>Plywood</i>
35-36	2	Wheelhouse floor grills	4 mm	<i>Plywood</i>
37..39 A	6	Laths bottom parts	4 mm	<i>Plywood</i>
40 A	1	Laths bottom part	4 mm	<i>Plywood</i>
37..40 B	8	Laths top parts	4 mm	<i>Plywood</i>
41	2	Machine room side wall	4 mm	<i>Plywood</i>
42...46	5	Machine room wall	4 mm	<i>Plywood</i>
47	6	Flexible plate supports	4 mm	<i>Plywood</i>
48...52	5	Machine cabin walls	4 mm	<i>Plywood</i>
53	2	Machine cabin wall support	4 mm	<i>Plywood</i>
54-55	4	Bollard parts	4 mm	<i>Plywood</i>
56(A-B)	2	Back grill	4 mm	<i>Plywood</i>
57-58	4	Rudder wheel box parts	4 mm	<i>Plywood</i>
59	1	Base front part	4 mm	<i>Plywood</i>
60	1	Base back part	4 mm	<i>Plywood</i>
61	2	Base side parts	4 mm	<i>Plywood</i>
PW-1	1	Front deck	1,5 mm	<i>Plywood</i>
PW-2	2	Middle deck	1,5 mm	<i>Plywood</i>
PW-3-4	2	Back deck	1,5 mm	<i>Plywood</i>
PW-5	2	Front rail panel	1,5 mm	<i>Plywood</i>
PW-6	2	middle rail panel	1,5 mm	<i>Plywood</i>
PW-7	1	Back rail panel	1,5 mm	<i>Plywood</i>
PW-8	1	Back bottom panel	1,5 mm	<i>Plywood</i>
PW-9A...22A	14	Rail support part	1,5 mm	<i>Plywood</i>
PW-9B...22B	14	Rail support part	1,5 mm	<i>Plywood</i>
PW-23R-29R	7	Rail frame right	1,5 mm	<i>Plywood</i>
PW-23L..29L	7	Rail frame left	1,5 mm	<i>Plywood</i>
PW-30...33	8	Rail top part	1,5 mm	<i>Plywood</i>
PW-34..37	4	Rail nose parts	1,5 mm	<i>Plywood</i>
PW-38	1	Wheelhouse front roof	1,5 mm	<i>Plywood</i>
PW-39	1	Wheelhouse roof	1,5 mm	<i>Plywood</i>
PW-40-41	2	Wheelhouse roof frame	1,5 mm	<i>Plywood</i>
PW-42	2	Wheelhouse roof frame	1,5 mm	<i>Plywood</i>
PW-43	6	Wheelhouse roof frame support parts	1,5 mm	<i>Plywood</i>

PW-44	6	Wheelhouse roof frame support parts	1,5 mm	<i>Plywood</i>
PW-45	2	Wheelhouse roof side led house	1,5 mm	<i>Plywood</i>
PW-46	1	Wheelhouse roof front led house	1,5 mm	<i>Plywood</i>
PW-47..50	8	Side light parts	1,5 mm	<i>Plywood</i>
PW-51	10	Wheelhouse windows frame	1,5 mm	<i>Plywood</i>
PW-52	2	Wheelhouse door frame	1,5 mm	<i>Plywood</i>
PW-53-54-55	6	Wheelhouse door parts	1,5 mm	<i>Plywood</i>
PW-56	2	Wheelhouse small door frame	1,5 mm	<i>Plywood</i>
PW-57-58	4	Wheelhouse small door parts	1,5 mm	<i>Plywood</i>
PW-59-60-61	6	Staff parts	1,5 mm	<i>Plywood</i>
PW-62-63	2	Staff parts	1,5 mm	<i>Plywood</i>
PW-64	2	Wheelhouse small grill	1,5 mm	<i>Plywood</i>
PW-65-66	2	Compass base parts	1,5 mm	<i>Plywood</i>
PW-67	2	Rudder wheel box parts	1,5 mm	<i>Plywood</i>
PW-68...71	4	Rudder wheel box parts	1,5 mm	<i>Plywood</i>
PW-72	2	Rudder wheel frame	1,5 mm	<i>Plywood</i>
PW-73-83	12	Wheelhouse cabin parts	1,5 mm	<i>Plywood</i>
PW-84-85-86	3	Box parts	1,5 mm	<i>Plywood</i>
PW-87-88	4	Box parts	1,5 mm	<i>Plywood</i>
PW-89	2	Bollard stand	1,5 mm	<i>Plywood</i>
PW-90	2	Bollard stand	1,5 mm	<i>Plywood</i>
PW-91	2	Middle cabinet parts	1,5 mm	<i>Plywood</i>
PW-92..95	4	Middle cabinet parts	1,5 mm	<i>Plywood</i>
PW-96	2	Left cabinet parts	1,5 mm	<i>Plywood</i>
PW-97...100	4	Left cabinet parts	1,5 mm	<i>Plywood</i>
PW-101	2	Right cabinet parts	1,5 mm	<i>Plywood</i>
PW-102...105	4	Right cabinet parts	1,5 mm	<i>Plywood</i>
PW-106	4	Machine room led house	1,5 mm	<i>Plywood</i>
PW-107	2	Back grill support parts	1,5 mm	<i>Plywood</i>
PW-108-109	2	Back grill support parts	1,5 mm	<i>Plywood</i>
PW-110	8	Led house	1,5 mm	<i>Plywood</i>
PW-111	16	Led house support	1,5 mm	<i>Plywood</i>
PW-112...115	16	Chair parts	1,5 mm	<i>Plywood</i>
PW-116-117	4	Chair parts	1,5 mm	<i>Plywood</i>
PW-118-119	12	Floor lid parts	1,5 mm	<i>Plywood</i>
PW-120-121	2	Small circular lid parts	1,5 mm	<i>Plywood</i>
PW-122	6	Rail lids	1,5 mm	<i>Plywood</i>
PW-123...125	6	Machine room sliding lid	1,5 mm	<i>Plywood</i>
PW-126...128	6	Machine cabin sliding lid	1,5 mm	<i>Plywood</i>
PW-129-130	2	Machine cabin top lid parts	1,5 mm	<i>Plywood</i>
PW-131	4	Machine cabin side lid parts	1,5 mm	<i>Plywood</i>
PW-132	2	Machine cabin side lid parts	1,5 mm	<i>Plywood</i>
PW-133...138	6	Machine room top lid parts	1,5 mm	<i>Plywood</i>
PW-139-140	4	Back lid parts	1,5 mm	<i>Plywood</i>
PW-141..143	3	Back lid parts	1,5 mm	<i>Plywood</i>
PW-144...146	3	Back lid parts	1,5 mm	<i>Plywood</i>
PW-147..149	6	Air conditioner cabinet parts	1,5 mm	<i>Plywood</i>
PW-150	4	Air conditioner cabinet lids	1,5 mm	<i>Plywood</i>
PW-151-152	2	Windcatcher base parts	1,5 mm	<i>Plywood</i>
PW-153...155	6	Windcatcher base parts	1,5 mm	<i>Plywood</i>
PW-156	2	Belt connector	1,5 mm	<i>Plywood</i>
PW-157 (L-R)	2	L grill (right&left)	1,5 mm	<i>Plywood</i>
PW-158	2	Wheelhouse tread	1,5 mm	<i>Plywood</i>
PW-159	4	Wheelhouse tread support	1,5 mm	<i>Plywood</i>
PW-160	1	Clock and gauge plate	1,5 mm	<i>Plywood</i>
PW-161	2	Stair body	1,5 mm	<i>Plywood</i>
PW-162	5	Stair treads	1,5 mm	<i>Plywood</i>

PW-163	2	Anchor house	1,5 mm	<i>Plywood</i>
PW-164	1	Back letters (İSTANBUL)	1,5 mm	<i>Plywood</i>
PW-165	2	Front letters plate (LİMAN.2)	1,5 mm	<i>Plywood</i>
PW-166	2	Front letters (LİMAN.2)	1,5 mm	<i>Plywood</i>
PW-167	1	Back letters (LİMAN.2)	1,5 mm	<i>Plywood</i>
PW-168	2	Door cover	1,5 mm	<i>Plywood</i>
<hr/>				
FLX-1	1	Machine cabin corner panel	1,5 mm	<i>Flexible</i>
FLX-2	1	Machine cabin corner panel	1,5 mm	<i>Flexible</i>
FLX-3	3	Machine cabin top lids	1,5 mm	<i>Flexible</i>
FLX-4	2	Machine room corner panel	1,5 mm	<i>Flexible</i>
FLX-5	2	Wheelhouse corner panel	1,5 mm	<i>Flexible</i>
<hr/>				
PLX-1	10	Wheelhouse window glasses	1 mm	<i>Plexi</i>
PLX-2	2	Wheelhouse door glasses	1 mm	<i>Plexi</i>
PLX-3	8	Air conditioning cabinet glasses	1 mm	<i>Plexi</i>
PLX-4	4	Wheelhouse porthole glasses	1 mm	<i>Plexi</i>
PLX-5	4	Floor porthole glasses	1 mm	<i>Plexi</i>
PLX-6	1	Small belt	1 mm	<i>Plexi</i>
PLX-7	3	Lifebuoy hanger parts	1 mm	<i>Plexi</i>
PLX-8	1	Telgraph back cap	1 mm	<i>Plexi</i>
PLX-9	1	Telgraph glass	1 mm	<i>Plexi</i>
PLX-10	1	Clock	1 mm	<i>Plexi</i>
PLX-11	1	Gauge	1 mm	<i>Plexi</i>
PLX-12	1	Gauge glass	1 mm	<i>Plexi</i>
PLX-13	1	Angle gauge	1 mm	<i>Plexi</i>
PLX-14	1	Projector glass	1 mm	<i>Plexi</i>
PLX-15...19	6	Winch body parts	1 mm	<i>Plexi</i>
PLX-20-21	3	Winch gear handle	1 mm	<i>Plexi</i>
PLX-22	1	Rudder pal	1 mm	<i>Plexi</i>
PLX-23	1	Lid belt	4 mm	<i>Plexi</i>
PLX-24	9	Lifebuoy hanger part	4 mm	<i>Plexi</i>
PLX-25	2	Hooh hanger	4 mm	<i>Plexi</i>
PLX-26	2	Porthole cover	4 mm	<i>Plexi</i>
PLX-27	4	Side lamp cover	4 mm	<i>Plexi</i>
PLX-28	1	Belt	4 mm	<i>Plexi</i>
PLX-29	1	Funnel support	4 mm	<i>Plexi</i>
PLX-30	1	Compass glass	1 mm	<i>Plexi</i>
PLX-31	1	Ballast stem	4 mm	<i>Plexi</i>
PLX-32	12	Rail lid hinge	1 mm	<i>Plexi</i>
PLX-33	12	Rail lid hinge	1 mm	<i>Plexi</i>
PLX-34	6	Machine room lid hinge	1 mm	<i>Plexi</i>
PLX-35	6	Machine room lid hinge	1 mm	<i>Plexi</i>
PLX-36	20	Machine cabin lid hinge	1 mm	<i>Plexi</i>
PLX-37	16	Door hinge	1 mm	<i>Plexi</i>
PLX-38	4	Air conditioner cabin hinge	1 mm	<i>Plexi</i>
<hr/>				
PVC-1	8	Door handle parts	1 mm	<i>Pvc</i>
PVC-2	8	Door handle parts	1 mm	<i>Pvc</i>
PVC-3	6	Lid handle	1 mm	<i>Pvc</i>
<hr/>				
M-1	1	Post	5 mm	<i>Massive</i>
M-2	8	Rudder wheel parts	3 mm	<i>Massive</i>
M-3	1	Hook stem	Ø3x95mm	<i>Dowel strip</i>
<hr/>				
S-1	160(net)	Cover strips	5.5x1,7x550 mm	<i>Linden</i>

3D-1	2	Anchor hopper ring	-	3D Resin
3D-2	2	Anchor	-	3D Resin
3D-3	2	Anchor shank	-	3D Resin
3D-4	1	Pipe	-	3D Resin
3D-5	1	Front single bollard	-	3D Resin
3D-6	4	Front dual bollard parts	-	3D Resin
3D-7	2	Middle single bollard	-	3D Resin
3D-8	4	Back dual bollard parts	-	3D Resin
3D-9	1	Front hanger	-	3D Resin
3D-10	2	Dual pulley	-	3D Resin
3D-11	3	Lamp	Clear	3D Resin
3D-12	1	Plate	-	3D Resin
3D-13	4	Porthole	-	3D Resin
3D-14	1	Compass	-	3D Resin
3D-15	1	Telgraph	-	3D Resin
3D-16	1	Telgraph stand	-	3D Resin
3D-17	1	Rudder whell box stand	-	3D Resin
3D-18	1	Rudder wheel house	-	3D Resin
3D-19	1	Rudder wheel center	-	3D Resin
3D-20	1	Rudder wheel pin	-	3D Resin
3D-21	8	Rudder wheel arms	-	3D Resin
3D-22	1	Clock	-	3D Resin
3D-23	1	Gauge	-	3D Resin
3D-24	1	Handle	-	3D Resin
3D-25	1	Hook	-	3D Resin
3D-26	3	Lifebuoy part	-	3D Resin
3D-27	3	Lifebuoy part	-	3D Resin
3D-28	20	Porthole wire	-	3D Resin
3D-29	4	Floor porthole	-	3D Resin
3D-30	4	Light house	Clear	3D Resin
3D-31	1	Projector body	-	3D Resin
3D-32	1	Projector lid	-	3D Resin
3D-33	1	Projektör base	-	3D Resin
3D-34	2	Winch chain hole	-	3D Resin
3D-35	1	Winch gear lock connector	-	3D Resin
3D-36	1	Winch gear lock	-	3D Resin
3D-37	1	Winch big gear	-	3D Resin
3D-38	2	Winch chain pulley	-	3D Resin
3D-39	2	Winch pulley	-	3D Resin
3D-40	1	Winch short shaft	-	3D Resin
3D-41	1	Winch long shaft	-	3D Resin
3D-42	2	Winch head	-	3D Resin
3D-43	2	Winch wheel (right&left)	-	3D Resin
3D-44	2	Winch stand	-	3D Resin
3D-45	2	Winch lock	-	3D Resin
3D-46	2	Winch lock handle	-	3D Resin
3D-47	3	Rudder hinge (keel)	-	3D Resin
3D-48	2	Rudder hinge (pal)	-	3D Resin
3D-49	1	Rudder big hinge (pal)	-	3D Resin
3D-50	1	Rudder-servo connector	-	3D Resin
3D-51	2	Box hinge	-	3D Resin
3D-52	4	Side lamp	Clear	3D Resin
3D-53	1	Single pulley	-	3D Resin
3D-54	2	Machine cabin top lid hinge	-	3D Resin
3D-55	2	Belt support	-	3D Resin
3D-56	12	Machine cabin side lid hinge	-	3D Resin
3D-57	6	Machine cabin curving lid hinge	-	3D Resin

3D-58	1	Horn upper parts	-	3D Resin
3D-59	1	Horn pipe	-	3D Resin
3D-60	1	Horn	-	3D Resin
3D-61	1	Bell	-	3D Resin
3D-62	1	Windcatcher upper pipe right	-	3D Resin
3D-63	1	Windcatcher upper pipe left	-	3D Resin
3D-64	2	Windcatcher tube cap	-	3D Resin
3D-65	2	Hook connector	-	3D Resin
3D-66	2	Hook bow	-	3D Resin
3D-67	2	Hook	-	3D Resin
3D-68	2	Windcatcher head	-	3D Resin
3D-69	2	Air conditioning	-	3D Resin
3D-70	8	Air conditioning lid hinge	-	3D Resin
3D-71	8	Air conditioning lid handle	-	3D Resin
3D-72	8	Air conditioning lid porthole	-	3D Resin
3D-73	1	Windcatcher tube	-	3D Resin
3D-74	1	Funnel upper tube	-	3D Resin
3D-75	1	Funnel upper part	-	3D Resin
3D-76	1	Funnel	-	3D Resin
3D-77	2	Funnel ballast	-	3D Resin
3D-78	2	Funnel ballast lid	-	3D Resin
3D-79	1	Propeller body	-	3D Resin
3D-80	1	Propeller pin	-	3D Resin
3D-81	1	Propeller center	-	3D Resin
3D-82	4	Propeller pal	-	3D Resin

ME-1	1	Rudder shaft pipe	Ø5x35 mm	Pipe
ME-2	1	Hinge pin	Ø0,8x** mm	Wire
ME-3	1	Winch support	Ø1x39 mm	Wire
ME-4	1	Rudder shaft	Ø3x150 mm	Wire

Y-1	1	Rope	1.5m	Rope
-----	---	------	------	------

R-1	2	Chain	20cm	Chain
R-2	16	Clear led	-	Electric
R-3	1	Red led	-	Electric
R-4	1	Green led	-	Electric
R-5	6	Resistance	-	Electric
R-6	1	Copper wire	-	Electric

RC-1	1	Shaft pipe	Ø7x 181mm	Tube
RC-2	1	Bush	-	Ready
RC-3	1	Engine	-	Ready
RC-4	2	Screw	M3x8	Ready
RC-5	4	Screw	M3x10	Ready
RC-6	1	Coupling	-	Ready
RC-7	2	Setscrew	M3x3	Ready
RC-8	1	Shaft	Ø3x267 mm	Wire
RC-9	1	Propeller keeper	-	Ready
RC-10	1	Setscrew	M3x3	Ready
RC-11	2	Nuts	M3	Ready
RC-12	1	Propeller	Included R/C kit	3D Resin
RC-13	1	Servo	-	Ready