

*H.M. Brig-Sloop*  
*Speedy 1782*  
Building Manual

Der Bausatz im  
Maßstab 1:64  
wurde umfassend  
recherchiert und  
so entwickelt,  
dass er das Schiff  
so zeigt, wie es

VM

VANGUARD MODELS  
BY CHRIS WATTON

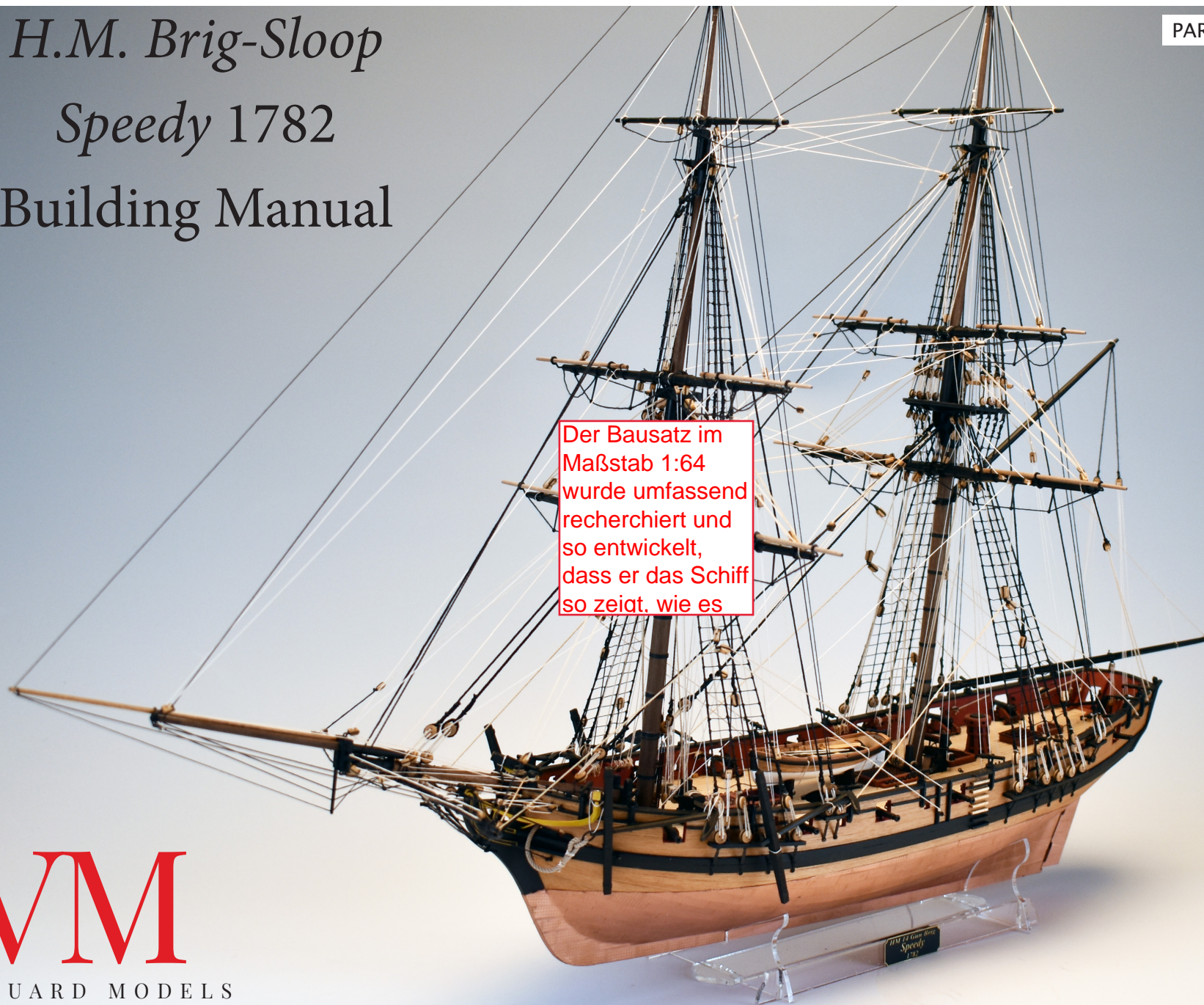

## ***HM BRIG-SLOOP SPEEDY***

### **HISTORY**

The Speedy was ordered on 2nd June 1781 and built by Thomas King, a private shipyard owner based in Dover and launched on 29th June 1782. She moved to Deptford, Kent, to be fitted-out and have her hull covered with copper plates between 16 July and 25 October 1782. At her completion she had cost £4,200 7s 3d to build. She had a sister, Flirt, built at the same time in the same shipyard, but it was the Speedy that gained a reputation that far exceeded that of her diminutive size.

The Flirt/Speedy class of brig-sloops were the second class built to the new flush decked brig-sloop designs, the first being the Childers class of 1779 (Childers was in the very first action that led to the long war with France from 1793-1815, after being fired upon on 2nd January 1793 from a French battery based in Brest, a cannon ball from the battery being taken to the Admiralty in London). Both the Childers and Speedy class were almost identical, and it would be difficult to tell the differences. Both were around the same dimensions, mast plans and armament and crew compliment. They also shared the same very graceful lines, more cutter-like than brig. These early flush decked brig-sloops had a graceful sheer and steeply raked stern, unlike the later Cruiser and Cherokee classes.

The term 'Brig-Sloop' means that she was a two-masted vessel, and on the Navy List sloop was a term given to a vessel which was commanded by an officer with the rank of master and commander. Speedy was 207 tons, the length of her upper deck was just over 78 feet and her breadth was 25 feet, 8 inches. She had a crew of between 84 men and 6 officers, with only two of the officers being commissions, the commander and his lieutenant.

Her armament consisted of 14 x 4-Pounder carriage guns and 12 x half-pounder swivel guns (There are 20 swivel gun posts in total on Speedy, as the swivel guns could be taken out of their posts and moved and placed in another post). When Cochrane took command in early 1800, he asked for, and was allowed, two 12-pounder carriage guns as fore and stern chasers, but there was little room for the crew to work them and the timbers struggled with the recoil. He later asked for 6-pounders instead of the diminutive 4-pounders, but the gun ports were not large enough to take them. So, throughout her career, Speedy's armament remained essentially the same.

Speedy was commissioned under Commander Josias Rogers in May 1783 and was assigned to serve in the North Sea, operating out of the Humber estuary. After four years on this station she was paid off (placed in reserve) in January 1787 and began a refit at Woolwich in April that year. This work was completed by July at a cost of £1,801, and she was recommissioned in May that year under Commander John Maude, still on the Humber station.

From November 1790 she was under Commander Richard Lane, who was her captain until she was paid off in October 1791. Speedy then underwent another refit, this time at Deptford between June and December 1792, at a cost of £3,000, and was recommissioned in November 1792 under Commander Charles Cunningham. He was largely employed in carrying despatches and maintaining communications with other ships scattered throughout the Mediterranean ports. On 5 October 1793 Speedy accompanied HMS Bedford and HMS Captain into Genoa, where they captured a French frigate, Modeste, and two armed tartanes in the Raid on Genoa. In this action, Speedy sent two boats to board the tartanes while Bedford bombarded Modeste. The French crews of the tartanes attempted to resist and two of their crewmembers were wounded, but the British did not suffer any casualties. Captain and Speedy then sailed to

the Gulf of Spezia where they caught another French frigate, Imperieuse, at anchor. Imperieuse was scuttled by her crew, but was subsequently salvaged and recommissioned as HMS Imperieuse. Cunningham was promoted to captain and given command of the prize, with his commission backdated to the day of the capture, 12 October 1793.

Cunningham was replaced by Commander George Cockburn in the command of Speedy, which remained in the Mediterranean. His first duties were limited to carrying despatches and passengers between Toulon and Genoa, after which he was ordered to join Captain Sutherland of HMS Diadem, who was commanding a squadron blockading Genoa. The small fleet was caught in winter storms and several ships were badly damaged, forcing Sutherland and his squadron to seek shelter in nearby ports and to make repairs, with the exception of the little Speedy, which remained on station. Once Diadem had been repaired Sutherland returned to Genoa, and was surprised to discover Speedy still there patrolling the port, not once having left her task. While single-handedly maintaining the blockade, she had managed to capture several vessels. Sutherland ordered Speedy, which was by now running desperately short of water, to Hyères to refit. At the same time, Sutherland sent a complimentary report of Cockburn to Lord Hood. On 20 January 1794, Cockburn was rewarded with an acting commission as post-captain of the frigate HMS Inconstant, followed a month later by a permanent command of the frigate HMS Meleager. [

Commander George Eyre took over command of Speedy in February 1794. Speedy supported the siege and capture of Bastia, after which Eyre was ordered to join Diadem off Nice. While making his way there on 9 June, he ran into a French fleet under Rear-Admiral Pierre Martin, which had sailed from Toulon several days earlier. Eyre attempted to escape, but the wind and sea favoured the larger vessels, and Speedy was chased down and captured. Speedy spent only a brief time sailing under the French flag. On 25 March 1795 her captain mistook Captain Thomas Fremantle's Inconstant for a French ship and she was recaptured and taken back into British service.

In early March the following year, Speedy, under the command of Thomas Elphinstone, joined a squadron cruising off Oneglia, Italy, under Commodore Horatio Nelson, consisting of the 64-gun ships HMS Agamemnon and HMS Diadem, the 32-gun frigates HMS Meleager and HMS Blanche and the ship-sloop HMS Peterel. (There is a superb modern painting of this group by Geoff Hunt). On 25 April the squadron steered for Laöna bay, the commodore having received intelligence that a large convoy, laden with stores for the French army, had anchored off the town of Finale. When the squadron arrived, however, they found only four vessels moored under the guns of some batteries. The shore batteries opened fire on Peterel as she led the boats of the squadron to the attack. Despite the fire, the British were able to capture the four vessels and suffered only three men wounded.

In an action on 31 May the squadron chased the French ketch Genie, a gunboat of one gun, and five merchant ships, which took refuge near the guns of a shore battery. At 3p.m. Agamemnon, Blanche, Peterel and Speedy approached them and anchored in 4 fathoms (7.3 metres) of water. The four British ships fired their cannons, which disabled the shore battery, and then sent in several boats under heavy fire from the guns of Genie and the gunboat; the British successfully boarded and captured both ships. In the meantime, the merchant ships had beached themselves to avoid capture. Under heavy musket fire from the beach, the British captured and re-floated the four merchant vessels, and destroyed one. Among the British, one man was killed and three were wounded in the operation.

Elphinstone was succeeded in August 1797 by Commander Hugh Downman, who made several cruises with Speedy. On 3 February 1798 Speedy encountered the large privateer Papillon, mounting 18 guns and carrying 160 men, while sailing off Vigo. Papillon attacked Speedy, which had a reduced crew; her

master Mr Marshall and 12 men were aboard a Spanish prize Speedy had taken earlier. The two ships fought each other for two days; by the second day Downman had exhausted his supply of shot, and resorted to firing nails and pieces of iron hoop at his opponent. Having observed his captain's predicament, Marshall secured the Spanish crew below deck and took the prize crew off in a small boat to go to Downman's assistance. After a fierce fight Speedy succeeded in driving off Papillon; Speedy suffered losses of five killed and four wounded. Downman then recaptured his prize and returned to Lisbon to carry out repairs.

For his efforts in protecting British trade out of Oporto, the merchants there presented him with a letter of thanks, and a piece of plate valued at £50. As a reward for his good service, Downman was advanced to post-captain on 26 December 1798 and appointed commander of the 32-gun HMS Santa Dorothea, a frigate that had recently been captured from the Spanish.

Downman was succeeded in January of the following year by Commander Jahleel Brenton, who was based at Gibraltar. While sailing off Gibraltar in company with the British privateer Defender on 9 August 1799, Brenton came across three small Spanish warships, mounting twenty 6-pounders in total. The Spanish ran into a small sandy bay and anchored in a line so as to bring their guns to bear simultaneously on the British ships. Speedy and Defender sailed up and down for two hours firing broadsides, but without much effect. Defender only had 22 men on board and decided to sail further out to sea to meet one of her boats. Brenton thought the effort of keeping under sail was aiding the enemy, and anchored Speedy within 30 yards (27 metres) of the middle ship. The two exchanged a fierce cannonade for three-quarters of an hour, after which the Spanish abandoned their ships and made for the shore. Two of the ships ran ashore and the third was immediately captured. Speedy launched her boats to recover the other two, coming under musket fire from the Spanish on the hillside as they did so. The British got both vessels off and took them into Gibraltar, along with two men wounded during the operation.

### **COCHRANE AND THE SPEEDY**

Brenton was promoted to post-captain, and in March 1800 Commander Lord Cochrane took over. Cochrane was less than impressed with his new command, declaring that Speedy was "little more than a burlesque of a vessel of war". His cabin had only 5 feet (1.5 metres) of headroom; when Cochrane wished to shave he had to open a skylight and set his shaving equipment out on the quarterdeck. On another occasion he walked the quarterdeck with Speedy's entire broadside, seven pieces of four-pounder shot, in his pockets.

In early May Cochrane was escorting a convoy from Cagliari to Leghorn. On 11 May a ship which turned out to be the 6-gun privateer Intrépide was spotted capturing one of the merchant ships in the convoy, at which point Cochrane chased the Intrépide and forced her to surrender. Three days later, as the convoy passed the island of Montecristo, five rowing boats emerged from one of the island's coves and captured two of the rearmost merchant ships. Cochrane immediately gave chase, and recaptured them early the next morning. He was then given a free hand to raid enemy shipping in the area, and captured seven or eight vessels that June and July, including the 10-gun privateer Asuncion off Bastia on 25 June and the privateer Constitution off Caprea on 19 July. On 22 September he captured a large Neapolitan vessel and, on bringing her into Port Mahon, discovered that the Spanish had taken notice of his depredations and were preparing a frigate to capture Speedy.

Cochrane prepared for an encounter with this Spanish vessel by painting Speedy to resemble the Danish brig Clomer, then in the Mediterranean. He also appointed a Dane as quartermaster and found him a Danish naval officer's uniform. While cruising off Alicante on 21 December, Speedy encountered an

enemy frigate, but tricked her into thinking she was a neutral vessel. Cochrane again used this false flag technique to his advantage; on 22 January he was sailing with a convoy of Danish merchantmen under a Danish flag, pretending to escort them. When a 10-gun French ship and 8-gun Spanish brig approached, Cochrane hoisted British colours and attacked, capturing both of them.

Then on 24 February Cochrane captured the French naval brig Caroline, of four guns, which had been carrying ordnance stores from Genoa to Alexandria.

Speedy was cruising off Barcelona at dawn on 6 May 1801 when she sighted a large enemy frigate. The frigate, a xebec-rigged vessel named Gamo, carrying 319 men, was armed with 8- and 12-pounder guns and 24-pounder carronades. This amounted to a total broadside of 190 pounds, more than seven times that of Speedy. Furthermore, Cochrane had only 54 men on board (the rest were serving as prize crews). Instead of evading the frigate, Cochrane closed on her, and at 9:30 am Gamo fired a gun and hoisted Spanish colours. In return Cochrane hoisted American colours. The Spanish hesitated, allowing Cochrane to get closer, hoist British colours, and evade the first broadside. Gamo fired another, which Cochrane again evaded, holding fire until Speedy ran alongside and locked her yards in Gamo's rigging. Gamo attempted to fire upon her smaller opponent, but her guns were mounted too high and could not be depressed sufficiently, causing their shot to pass through Speedy's sails and rigging. Cochrane then opened fire with his 4-pounders double- and treble-shotted, their shots passing up through the sides and decks, killing the Spanish captain and boatswain with the first broadside.

Aware of their disadvantage, the Spanish second-in-command assembled a boarding party, at which Cochrane drew off and pounded their massed ranks with shot and musket fire before drawing in close again. After having their attempts to board frustrated three times, the Spanish returned to their guns. Cochrane then decided to board the Gamo, and assembled his entire crew into two parties, leaving only the ship's doctor aboard. The British rushed the Gamo, some boarding from the bow with faces blackened to look like pirates to make them appear terrifying, the rest boarding from the waist. There was a hard-fought battle between the two crews, until Cochrane called down to the doctor, at the time the only person on Speedy, ordering him to send another 50 men over. At the same time he ordered the Spanish colours to be torn down. Thinking that their officers had surrendered the ship, the remaining Spanish seamen stopped fighting. The British had lost three men killed and nine wounded, while the Spanish had lost 14 killed and 41 wounded, a casualty list exceeding Speedy's entire complement. The British then secured the Spanish prisoners below deck and made their way back to Port Mahon. Stung that he had been beaten by such an inferior foe, the Spanish second-in-command asked Cochrane for a certificate assuring him that he had done all he could to defend his ship. Cochrane obliged, with the equivocal wording that he had "conducted himself like a true Spaniard". Cochrane was amused to learn that this certificate had later secured the Spanish officer further advancement. In 1847 the Admiralty awarded the Naval General Service Medal with clasp "Speedy 6 May 1801" to all surviving claimants from the action.

Cochrane returned to the coast off Barcelona in June 1801, and joined the 16-gun HMS Kangaroo in attacking a Spanish convoy of 12 merchant ships and 5 armed vessels anchored under the guns of a large tower. After a sharp action fought between the afternoon of 9 June and the morning of 10 June, the two ships sank or drove ashore all of the ships with the exception of three brigs, which they captured. Three weeks later he was cruising off Alicante when he encountered several merchant vessels, which ran ashore. Rather than wasting time trying to get them off, he burnt them, but in doing so attracted the attention of a foe vastly more powerful than the Gamo.

A formidable French squadron under the command of Rear-Admiral Charles-Alexandre Léon Durand Linois had left Toulon bound for Cadiz to collect reinforcements for Napoleon's army in Egypt. On 3 July they sighted and chased Speedy, and Cochrane ordered the guns, boats, and provisions thrown overboard to lighten the ship. The French caught up nonetheless, and after narrowly avoiding the broadside of Desaix, Cochrane struck his colours. He was taken aboard Desaix, where her captain, Christy-Pallière, recognised Cochrane's accomplishments by refusing to accept his sword.

In Speedy's 13-month cruise, Cochrane captured, burned, or drove ashore 53 ships before three French ships of the line under Admiral Charles-Alexandre Linois captured him on 3 July 1801. While Cochrane was held as a prisoner, Linois often asked him for advice. In his autobiography, Cochrane recounted how courteous and polite the French officer had been. A few days later, he was exchanged for the second captain of another French ship. On 8 August 1801, he was promoted to the rank of post-captain.

The French took Speedy to Toulon with the fleet, where she became a pawn in Napoleon's efforts at diplomacy with Pope Pius VII, whose presence he wanted at his coronation as emperor. Speedy, by now named Saint Pierre and inscribed with the words "Donné par le premier consul Bonaparte au Pape Pie VII" ("Given by the First Consul Bonaparte to Pope Pius VII") in gilt letters on her poop, sailed with an escort from Toulon on 14 December 1802 bound for Civitavecchia as a present to the Pope. She arrived there on 16 December where the Papal Navy took her into service under the name San Paulo. She remained there until being broken up in 1807.

Some of Speedy's later exploits under Cochrane were used in the plot of the novel *Master and Commander*, the first of Patrick O'Brian's *Aubrey–Maturin* series, though the ship described by O'Brian matches only Speedy's spar dimensions and armament, and is named HMS Sophie. Cochrane is replaced in the book by the fictional Jack Aubrey, who repeats many of Cochrane's real-life exploits including the defence of a convoy and the recapture of one of its merchants from a privateer, and the capture of a large Spanish frigate, based on the *Gamo*, but renamed *Cacafuego* for the novel. It is also thought that Aubrey's friend and surgeon, Maturin, is based on Cochrane's long friend and surgeon Guthrie.

---

#### REFERENCES:

Cordingly, David (2007). *Cochrane the Dauntless*. London: Bloomsbury. ISBN 978-0-7475-8545-9.

Henderson, James (2005) [1975]. *Frigates, Sloops and Brigs: An Account of the Lesser Warships of the Wars from 1793 to 1815*. Barnsley: Pen and Watch. ISBN 1-84415-301-0.

Hunt, Geoff (2004). *The Marine Art of Geoff Hunt*. London: Anova Books. ISBN 0-85177-971-9.

Woodman, Richard (2014), *The Sea Warriors*. Seaforth Publishing. ISBN-10: 184832202X & ISBN-13: 978-1848322028

Lyon, David (18 Nov. 1993). *The Sailing Navy List: All the Ships of the Royal Navy - Built, Purchased and Captured, 1688-1855*. National Maritime Museum. ISBN-10: 0851776175 & ISBN-13: 978-0851776170

Wikipedia

#### THE KIT

I never intended to develop Speedy at all, I had never really paid it much attention (to my shame). That is, until I looked closer at the unusually graceful lines from the original Admiralty plans and started reading books like 'Sloops and Brigs' by James Henderson, 'The Sea Warriors' by Richard Woodman and 'Cochrane the Dauntless' by David Cordingly (All three of these books are highly recommended, the latter especially for a complete biography of Cochrane's incredible life and exploits). The action that Speedy took part in eclipses most fighting vessels three times her size, and she was commanded by some of the best fighting men of the time, in actions more remarkable than some of the fictionalised accounts the real actions are based upon. I decided to make Speedy my second kit in the Vanguard Models range.

The Speedy kit has been researched to depict her as she most likely appeared during Cochrane's 15 month command from 1800-1801. She is shown with the Flying Jibboom and no crowsfeet on the fore and main tops, as these were being phased out during this time. I have included the euphroe blocks in the photo etched sheets, however, and have kept the holes for the crowsfeet to the lower half of the fore and main top patterns. If you wish to add the crowsfeet, simply drill the holes to the upper rim pattern.

The model kit is designed to be as accurate as possible for a commercial kit in both scale and detail. Although the kit of Speedy is as easy to build as we can make it, very basic woodworking skills (and patience) are still required. Estimated build time is between 50 to 70 hours, so a work space will have to be put aside for the job. Do not remove parts from the laser cut sheets until actually required for fitting, as they can be easily damaged or lost.

Take plenty of time to study this manual until you are confident enough to tackle each stage of construction. Patience is the key word when building any scale model. Treat each stage as a separate project and the overall effect of the completed subject will be much enhanced.

Care should be taken when cutting parts from the laser and brass etched sheets. The sheet from which you are going to cut the parts should be laid on a hard, flat surface. Use a heavy duty craft knife (a Stanley Knife is perfect and is and always has been my staple for all manner of cutting) with a good strong blade to cut through the tabs holding the parts in place. Before removing the wooden parts from their sheets, they should be numbered by reference to the cut file identification drawings. It is easier to paint most of the photo-etched parts before removing them from their sheets. They can be touched up again once in place on the model.

The metal cannon balls should be blackened before gluing in place. You can either paint them or blacken them using a solution for brass burnishing, which is listed below.

When painting parts in wood, use multiple coats with fine sanding in-between each coat to help minimise the grain visibility. Never settle on just a single coat, but take your time with every single sub assembly. Regarding the main wale and run of the hull planking, the main wale was actually part of the main planking, except the wale was thicker. Many models show the wale with a different curve to the main hull planking, when in fact it should run at exactly the same lines as the main planking. This can detract from the overall finish of the completed model. This is why I recommend starting the second planking at main wale level, as this guarantees the run of both main wale and second planking will be the same.

I have included a building cradle on the 3mm MDF laser sheet that is for use when building the model, marking the waterline etc. Do not make up the clear acetate cradle until the model is complete.

## RECOMMENDED TOOL LIST

(All items listed were used by the designer to build the Speedy prototype model)

- 1: Craft knife (or standard Stanley Knife, which is robust enough for most jobs)
- 2: A selection of needle files
- 3: Razor saw
- 4: Small wood plane
- 5: Pin vice or small electric drill (the latter is the more recommended item)
- 6: Selection of drill bits from 0.5mm to 2mm
- 7: Selection of abrasive paper and sanding block
- 8: Selection of good quality paint brushes
- 9: Pliers/wire cutters (Good quality side cutters are excellent for trimming rigging ends)
- 10: Good quality set of tweezers (For small parts and rigging)
- 11: Steel ruler (300mm - for providing a straight edge for tapering the planking)
- 12: Clothes pegs or small clamps
- 13: Good quality pencil or drawing pen
- 14: Masking tape (Tamiya masking tape is perfect for masking areas around the main wale)
- 15: Waterline marking out tool
- 16: A Pin Pusher (Or you can just use a pair of pliers to push pins into the planking and bulkhead edges)
- 17: Cutting mat

*Although not strictly required, access to a lathe would be very beneficial for turning the upper masts and yards, although the yards are easily tapered using a small wood plane and abrasive paper to smooth the surface.*

## PAINTS, STAINS AND ADHESIVES

- 1: White PVA wood glue
- 2: Cyanoacrylate (superglue) thick and medium viscosity
- 3: Natural colour wood filler
- 4: Indian ink (Black for ratlines)
- 5: Matt polyurethane varnish (Not satin or gloss)
- 6: Black paint (Humbrol 85) 3 tins or Vallejo matt black
- 7: Yellow paint (Ochre) (Humbrol 24) 1 tin
- 8: Red paint (Humbrol matt 60 for inside of bulwarks, cannon carriages and various deck fittings)
- 9: Copper Paint (Humbrol MET 12)
- 10: Metal burnishing/blackening liquid (AK Interactive AK 174 - brass Photo etch Burnishing) or similar
- 11: Clear Epoxy Resin or similar to glue the clear acetate stand together

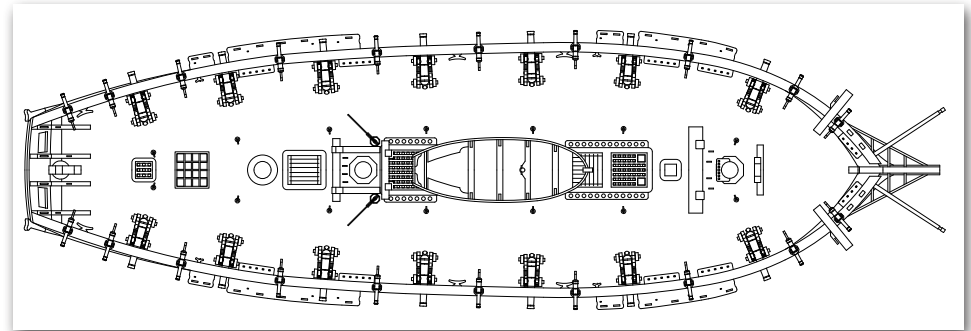
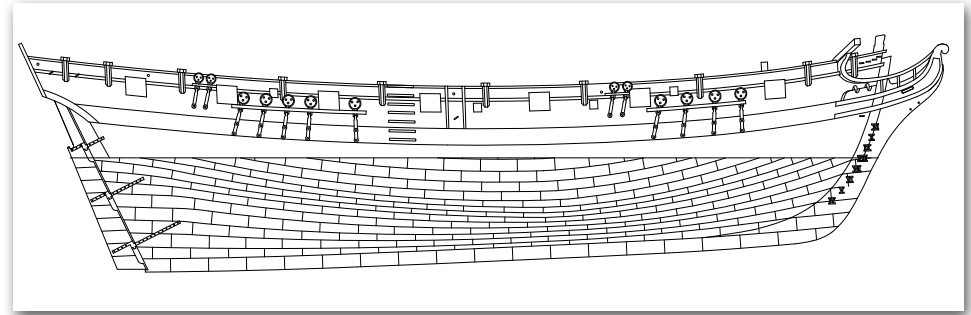

## HULL CONSTRUCTION

1 - Using the parts identification plan, identify and number each part relating to the hull construction

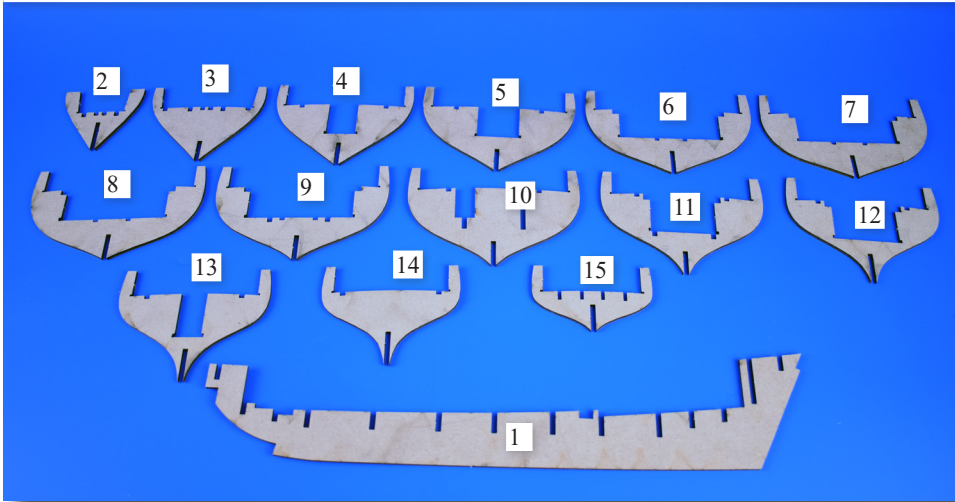

2 - Slot and glue bulkheads 4-13 into their respective slots in the false keel (1). Slot and glue parts 22 to bulkheads 9, 10 and 11. Parts 22 help support the stepped lower decks.

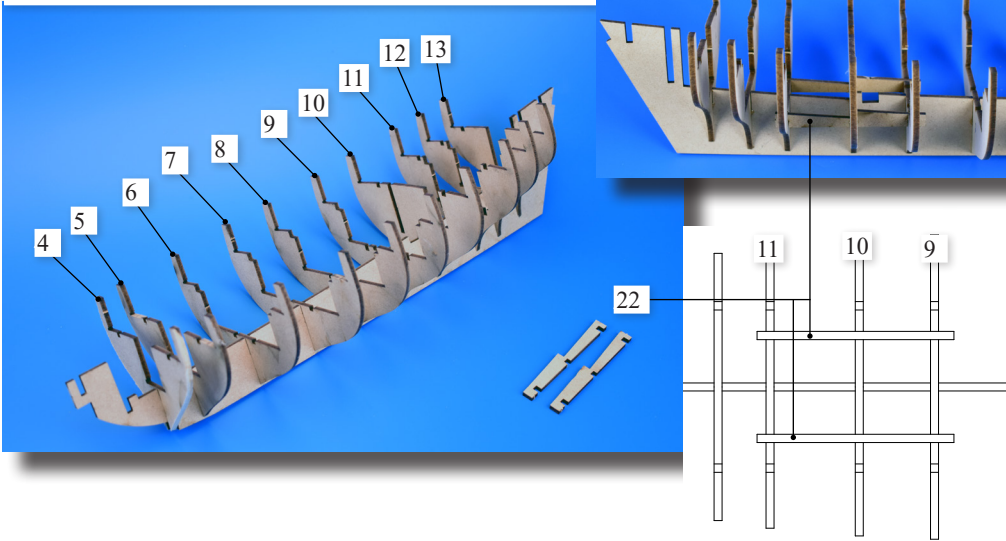

3 - Remove the 4 parts that make the lower decks (28 & 29) and slot and glue in place

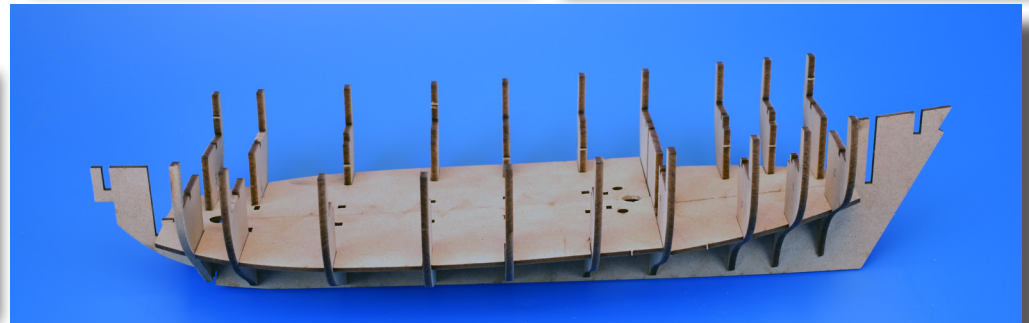
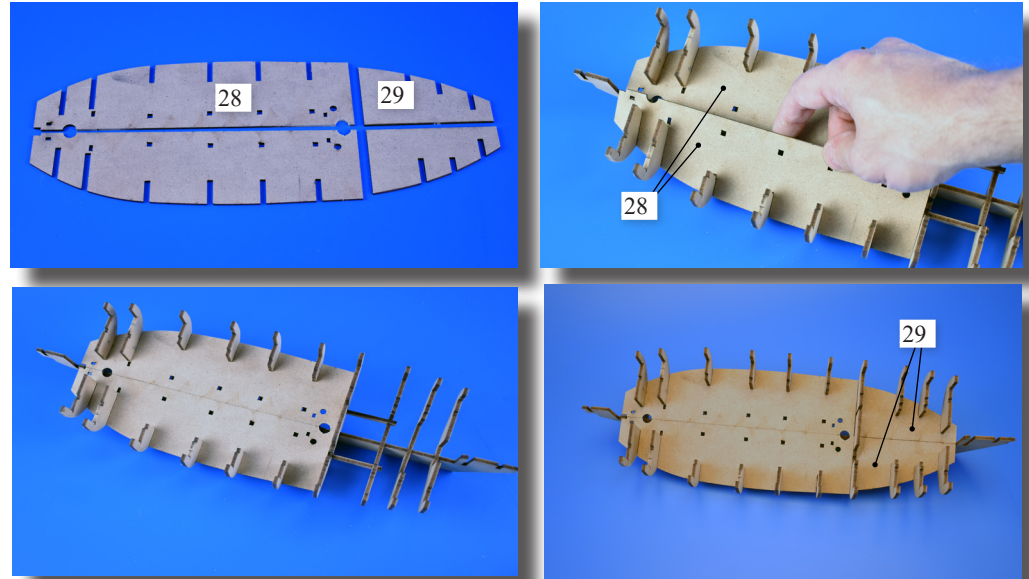

4 - The first 2 bulkheads (2&3) can now be made ready for slotting into place, along with the bow planking patterns (17&18). It is recommended that the edges are bevelled slightly before fixing in place, to be finished off once the basic hull assembly is complete.

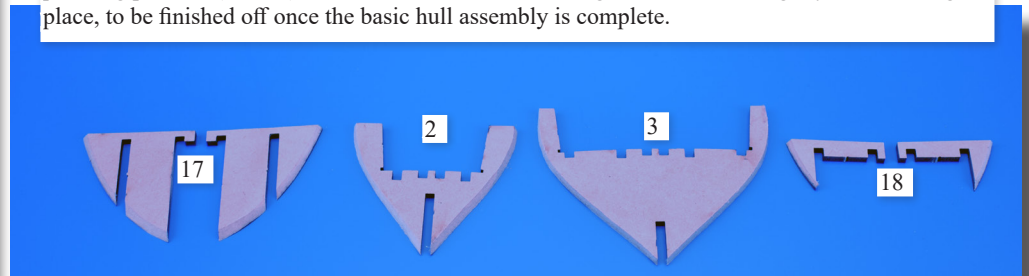

Slot and glue bulkheads 2 and 3 into position and then slot and glue parts 17 into position either side of the false keel, followed by parts 18, which are fixed to bulkheads 2 and 3.

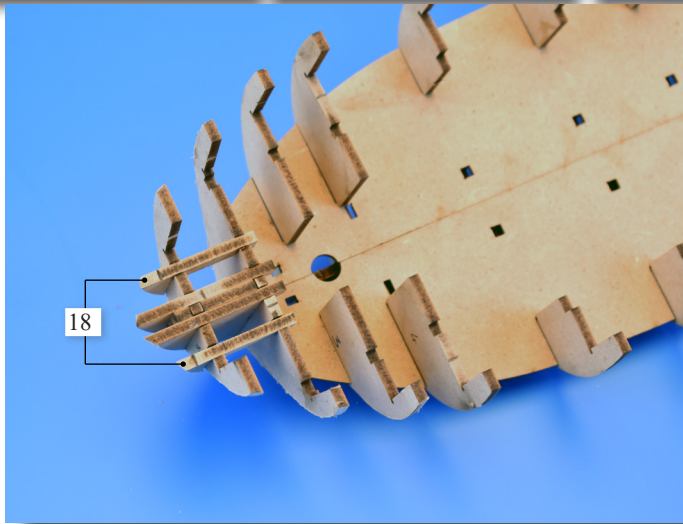
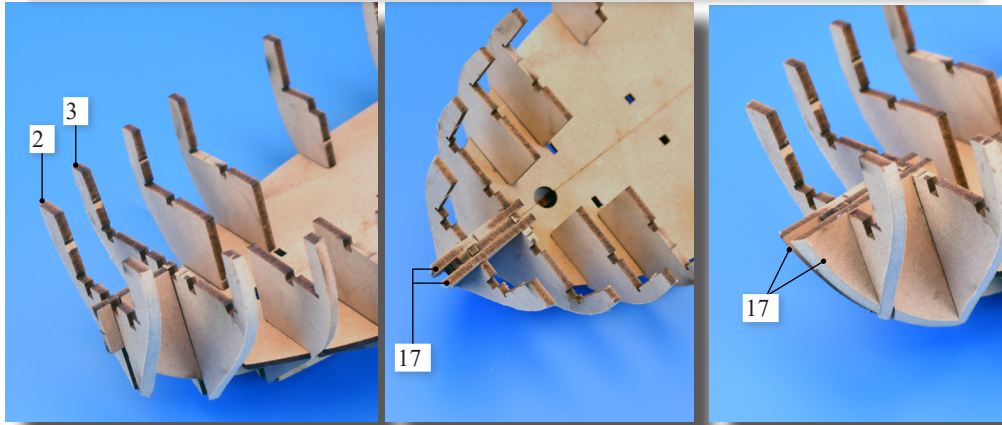

5 - Remove the upper deck beam patterns (6a, 7a, 8a, 9a, 11a and 12a) and glue each into their respective positions on the correspondingly numbered bulkheads.

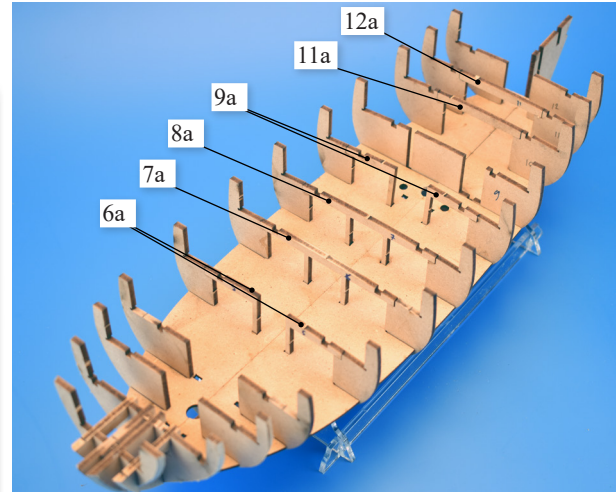
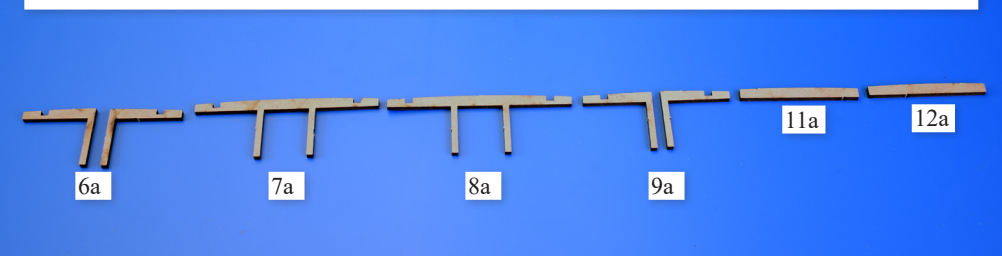

6 - Lightly bevel the planking contact edges of the three remaining bulkheads, 14 and 15 and slot and glue into place. The stern bulkhead, 16, required bevelling both on the hull planking contact edges and the top edge, where the deck will sit.

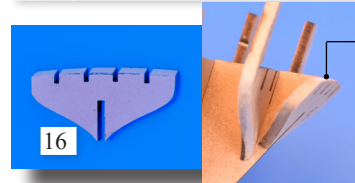

Top edge of bulkhead 16 bevelled to match angle of top edge of false keel

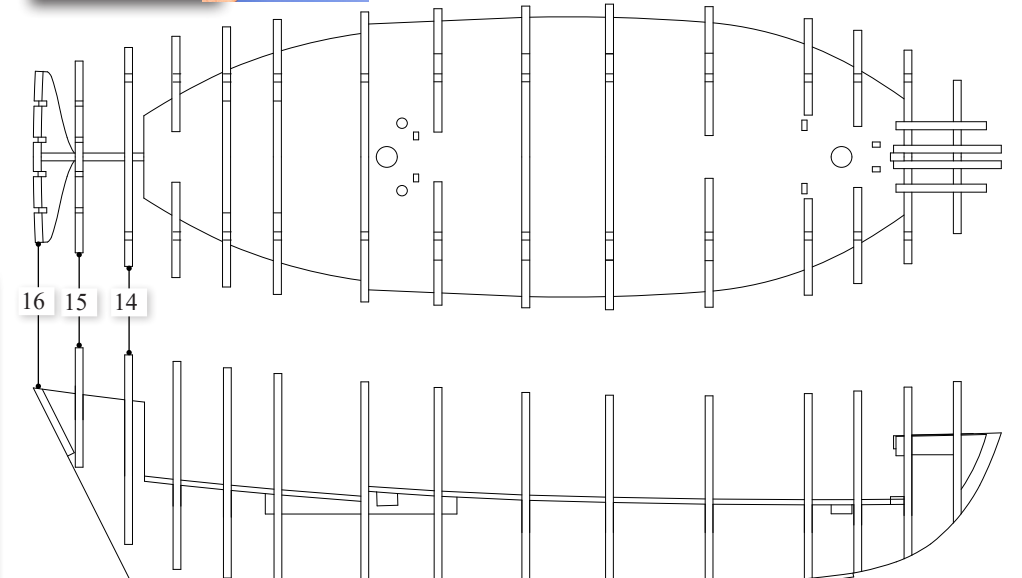
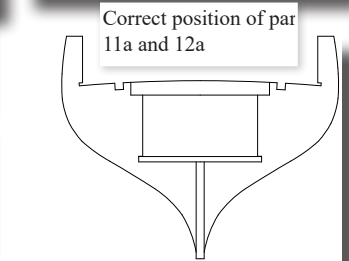
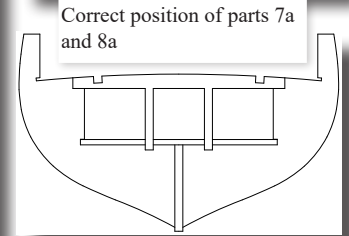
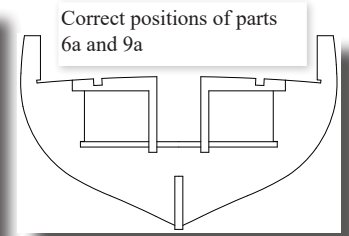

7 - Upper deck longitudinal supports (23). carefully slot and glue the two supports into the slots on the top edge of bulkheads 3 to 14.

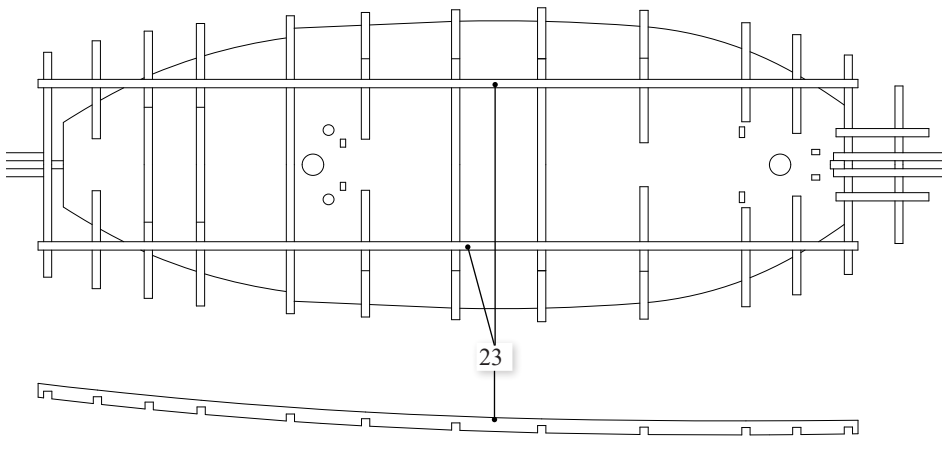

8 - Bevel and then glue the bow patterns (19 and 20) in place in between bulkheads 3 and 4 for parts 20 and bulkheads 4 and 5 for parts 19. Add the rear patterns (21) to the position shown.

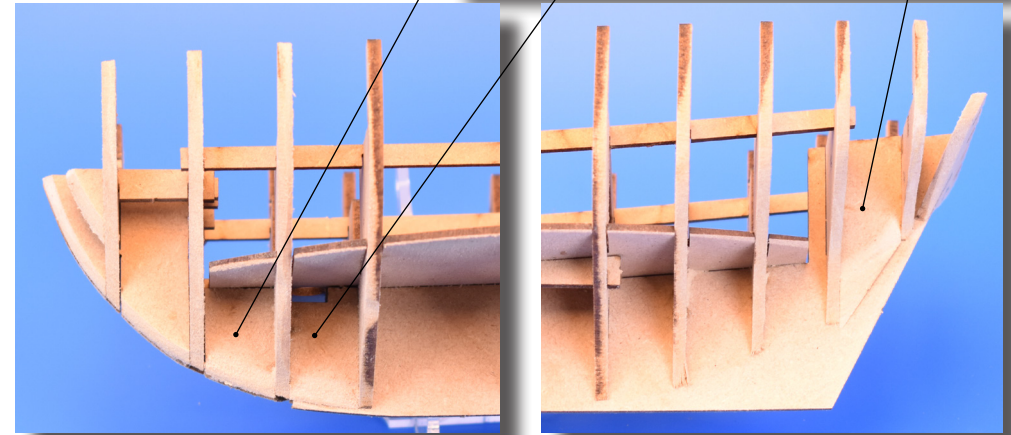
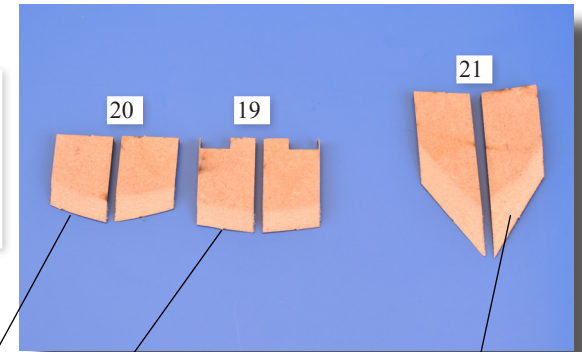

9 - Stern frame patterns 30 and 31. Slot and glue the two pairs into position on bulkheads 15 and 16. Note that parts 30 are the inner patterns and 31 the outer patterns.

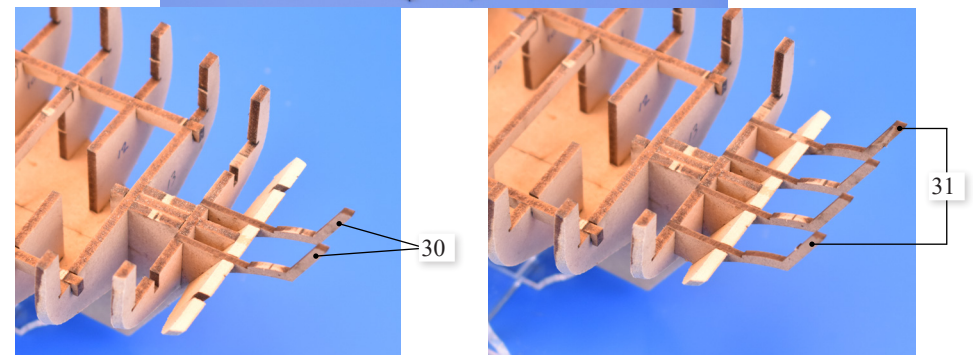
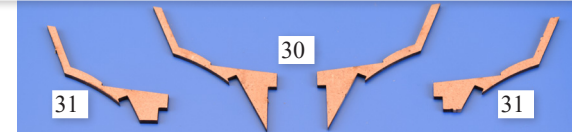



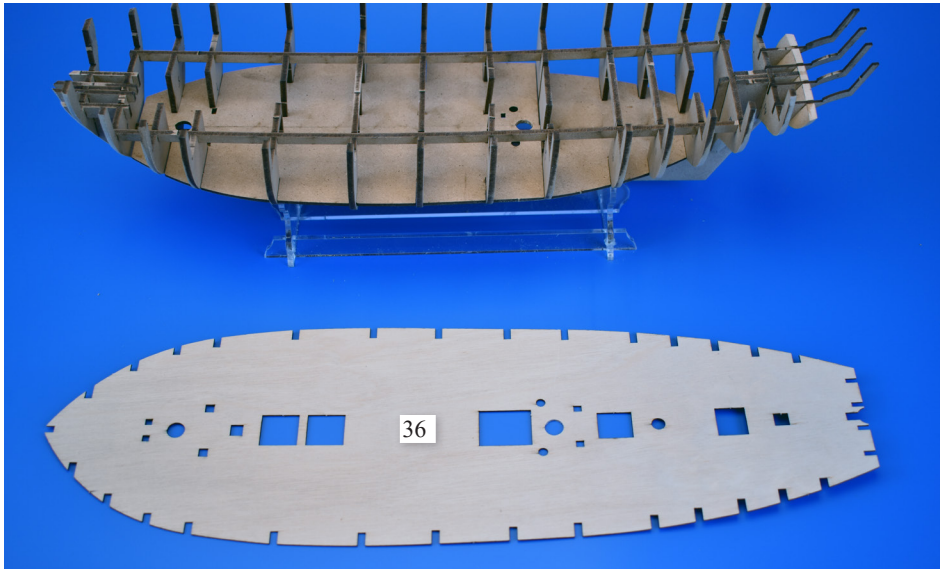

10 - Add the main deck (36). Glue the top edges of the contact areas of the bulkheads and longitudinal frames. Carefully bend the ply deck across its width and make sure each slot pushed into the slots located in the bulkhead frames. The outer edges of the deck do not need to be pinned down, but pin the area of the deck at the centre line to ensure the deck remains flat against the deck beams whilst the glue (PVA wood glue) cures.

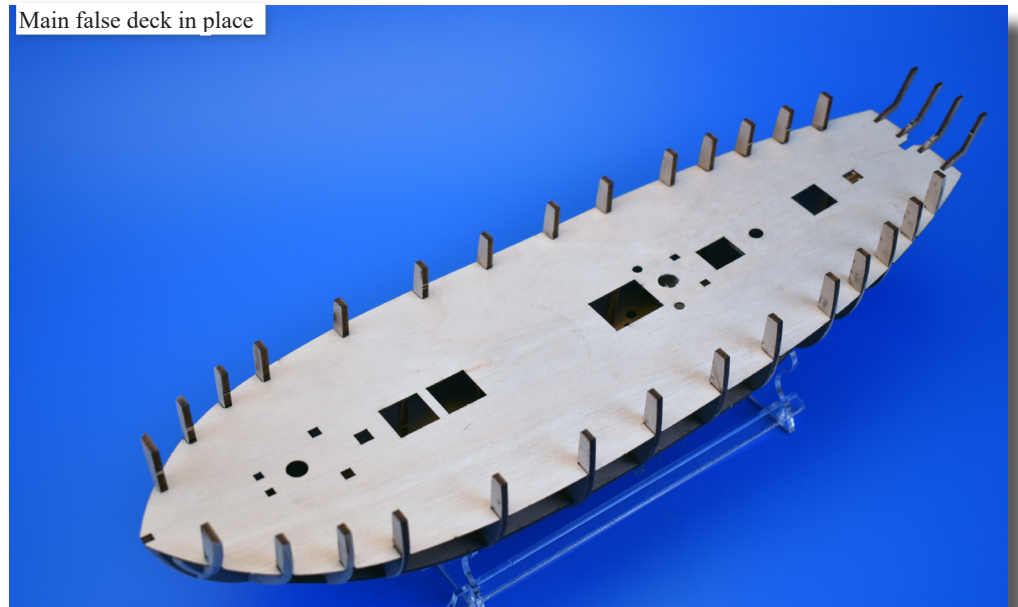
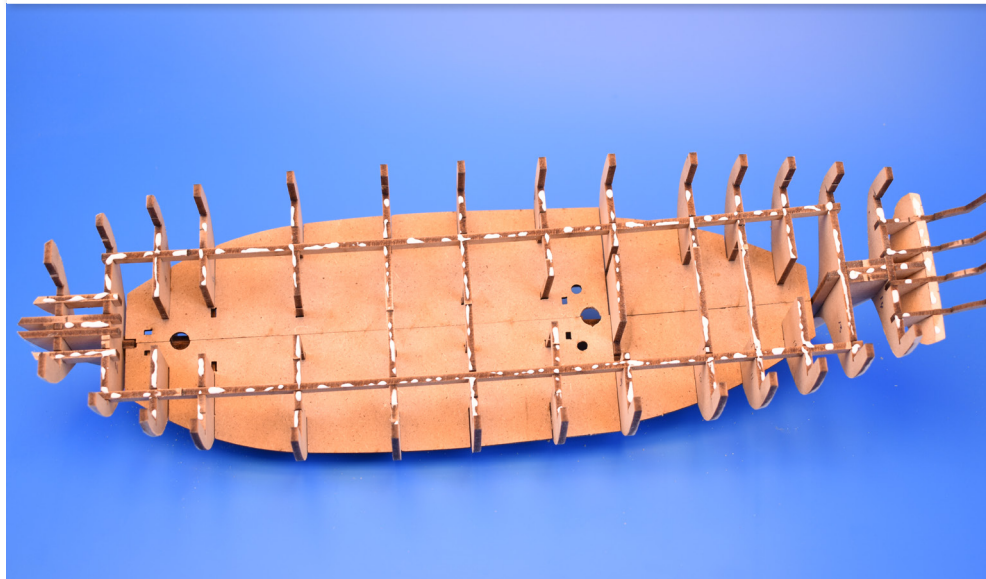

11 - The stern frames are very fragile, so we need to protect these by adding the lower and upper stern patterns (38 and 39) at this stage. To help with alignment for part 38, clamp the rudder post (110) in place, but DO NOT GLUE at this time. Pin and glue, or clamp and glue the stern counter (38) in place and once fully cured, glue and clamp the stern board (39) in place to the upper stern frames.

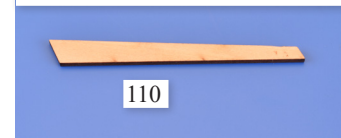

Left - Temporarily clamp or pin the rudder post (110) in place and then pin and glue the stern counter (38) in place. The rudder post will ensure part 38 sits in the correct position.

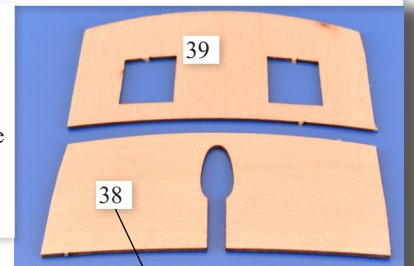

Right and below - Part 39 glued and clamped in place

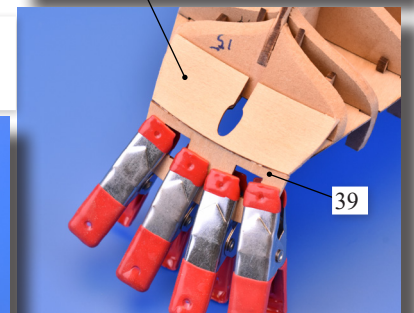
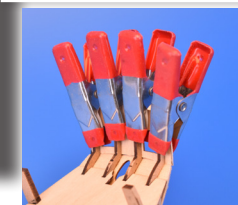

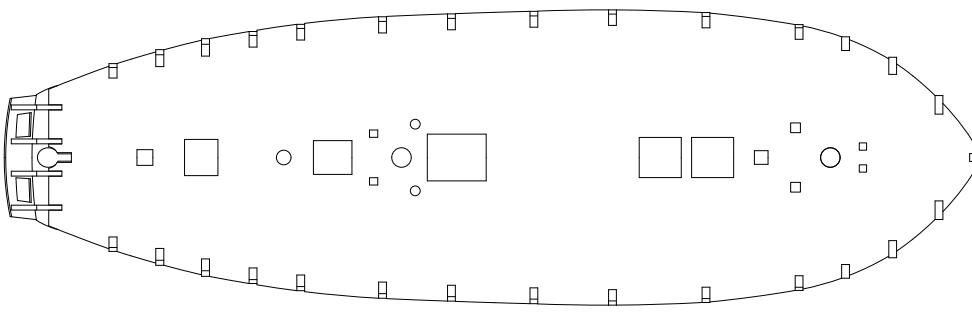
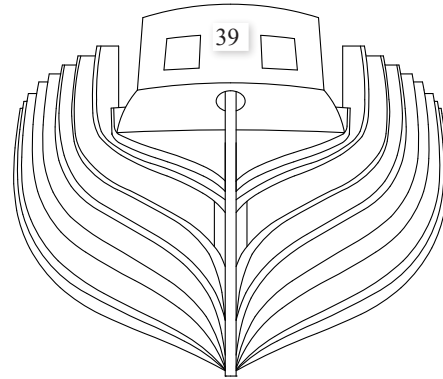
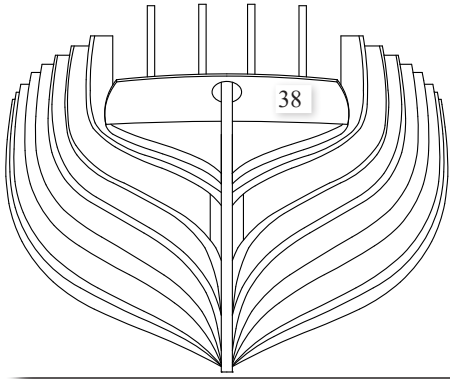

12 - Once fully cured, carefully sand the edges of the stern patterns so that the lower counter edge is flush with the deck edge.  
Also give the fore and aft bulkheads a final sand for the gun port patterns and planking have maximum contact with the edges of the bulkheads.

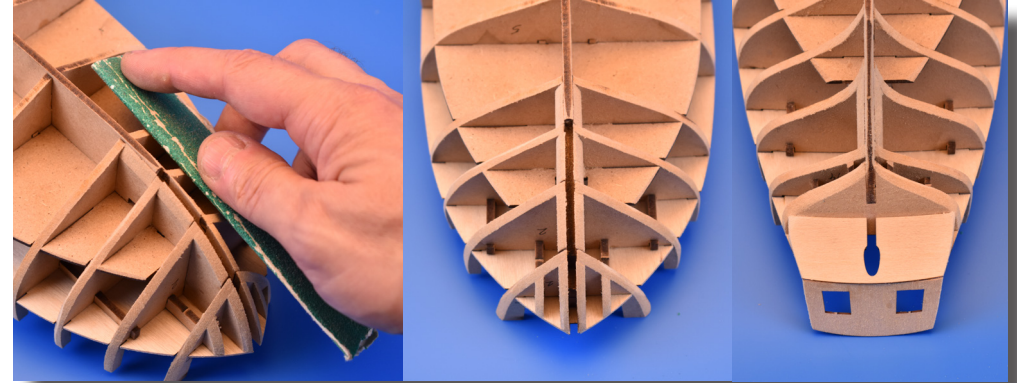

13 - As the hull frames are now sanded and bevelled, the inner stem post (107) and be slotted and glued in place as shown below. Dry fit the part first, to make sure it fits as it should.

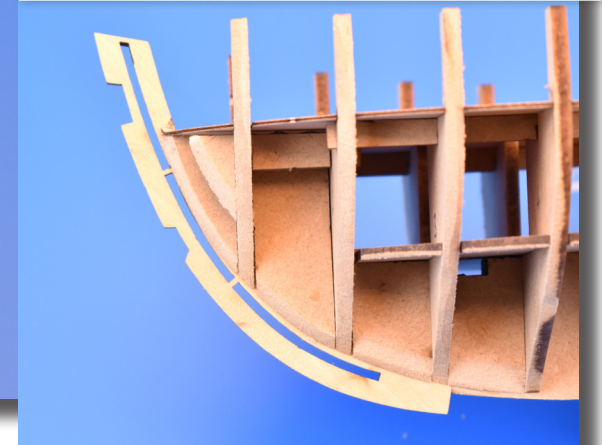

14 - the gun port patterns are now ready to be glued in place along the upper bulkheads. Remove the 2 sets (37 and 37a) and soak in warm water for about half an hour, to make them more pliable to bend around the bow frames.

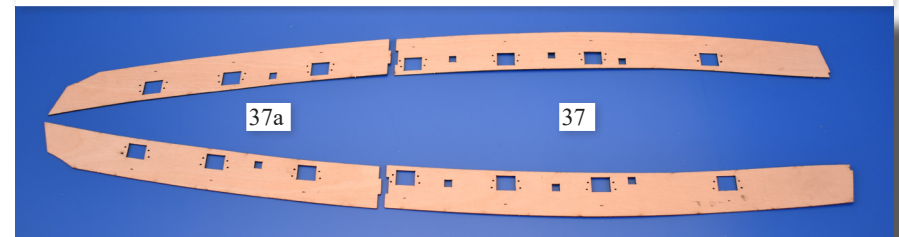

Apply the front gun port patterns first (37), followed by the rear patterns (37a). The top half can be clamped in place while the glue cures, and the bottom half of the patterns pinned to keep the lower edges in contact with the bulkheads.

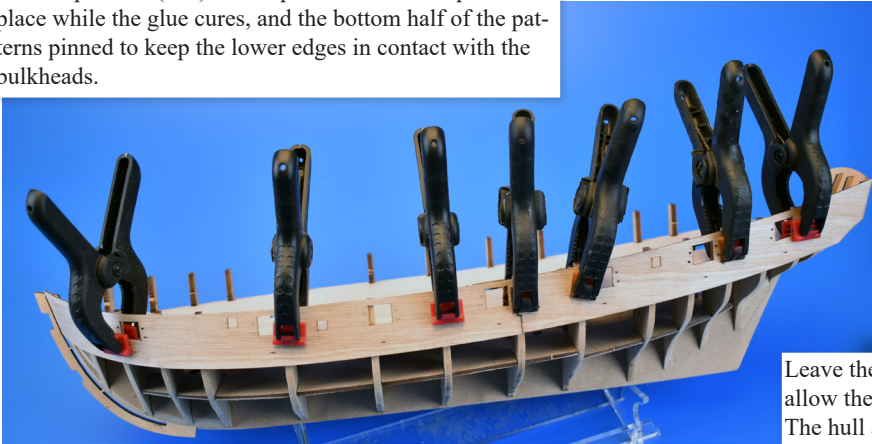

Leave the clamps and pins in place for 24 hours to allow the glue to fully cure. The hull assembly should now be strong enough to start the first planking.

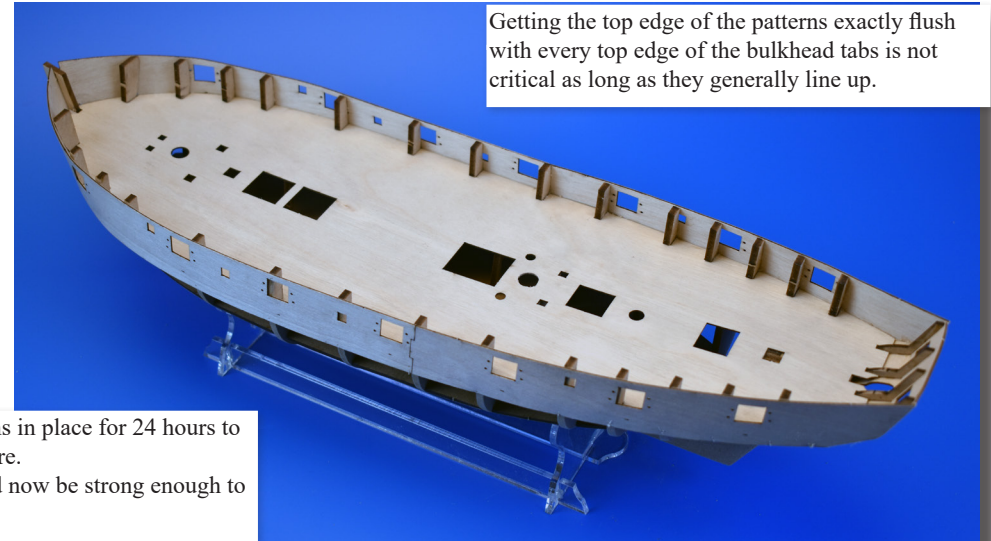
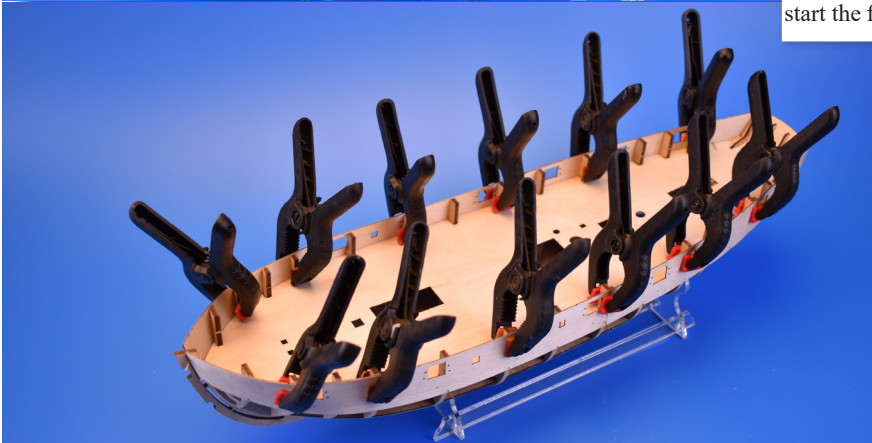

Getting the top edge of the patterns exactly flush with every top edge of the bulkhead tabs is not critical as long as they generally line up.

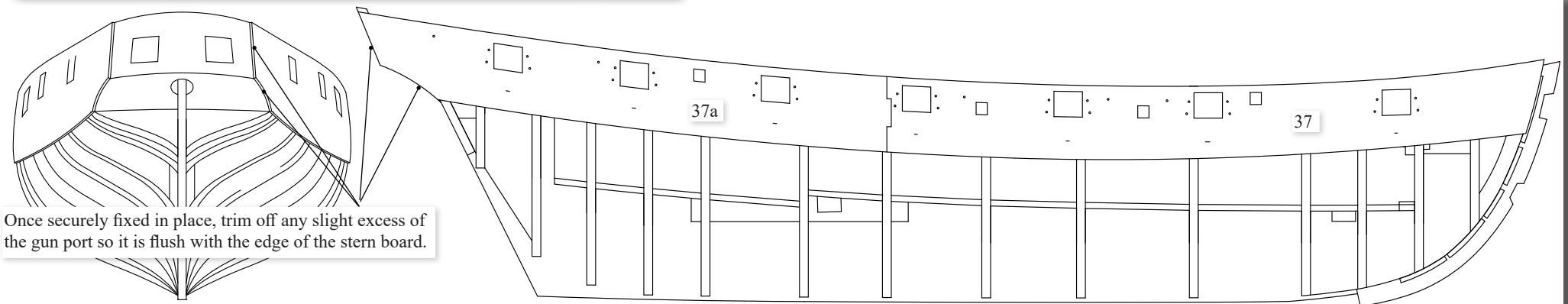
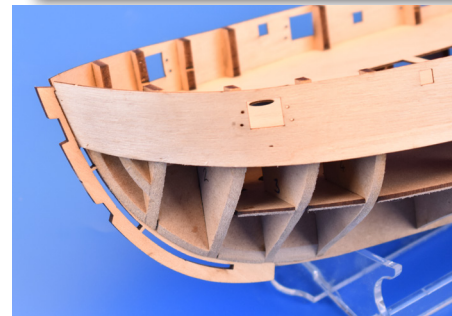

Once securely fixed in place, trim off any slight excess of the gun port so it is flush with the edge of the stern board.

## 15 - First Planking

The first planking should now be ready to be laid using 1.5x5mm lime wood strip. The first or 'master plank' is to be laid at the bottom edge of the gun port/bulwark pattern as shown.

When pushing the brass pins into the planks and bulkheads, leave at least half of the pin length protruding so they can be easily removed with the use of a pair of flat nose pliers once the planks are secure. Use PVA wood glue to fix the planks to the edges of each bulkhead.

The first couple of planks each side should be relatively straight forward to apply as only mild tapering is required. As you start down and along to the curved side of the bow, the planks will need to be tapered to follow the natural run of the planks.

To determine the amount of taper needed for each plank to lie naturally, lay a plank at the fifth or sixth bulkhead and then lay it around the bow. Mark the excess area of plank that overlaps the one directly above it. Repeat this technique for the stern also.

Although the planks may not require tapering at the stern, it is advisable to let the planks run as natural as possible which helps avoid any possible 'springing' of the planks when sanding. Before cutting the taper into the planks, soak them in warm water for half an hour or so as this minimises the chance of the blade of the knife following the grain of the wood rather than the edge of the steel rule.

Lay the first wet plank to be tapered on a clean, flat surface; (a cutting mat is well suited for this and is highly recommended.) Press firmly with a steel rule onto the marked taper line on the plank and score down the line with a heavy-duty craft knife several times until the excess is cut off. Pin and glue the tapered planks into position on the hull, leaving a little excess at the stern which can be trimmed to shape once the planking is complete. Glue two or three strips each side alternately. This method should prevent any possible twisting/warping of the frames and keel as the glue cures.

Use this planking technique right down to the keel. When planking is almost complete, triangular shaped gaps at the stern will be apparent. This was also the case in full size practise, although not so simplified. The use of triangular shaped planks is needed for the gap in-between the top and bottom edges of the planks, usually near the stern. The correct name for these triangular shaped planks is called stealers. Cut these to shape using the excess lime wood from the ends of the planking and glue them into the gaps. Trim off the excess stern planks to shape and leave the hull for the glue to fully cure for at least 24 hours (48 hours is recommended)

Sand the whole hull that has been planked with a coarse grade abrasive paper, followed by medium grade. This will entail about an hour's work. If possible, sand the hull in a well-ventilated area, ideally in an open space as the dust particles could present both a fire and health hazard. The use of light duty gloves is also recommended to reduce any risk of blisters from sanding. Alternatively, you could use a small electric sander, like a sanding mouse, which will be much quicker.



Above - marking the taper starting position onto the plank. When the plank overlaps the gun port pattern, mark out and taper this area.

Below - Marking out the taper starting position at the stern.



Planking progress continued. Do not wet the planks too because if they are soaked with water, as the planks lose the water content, they shrink, which will leave large gaps in between each plank.

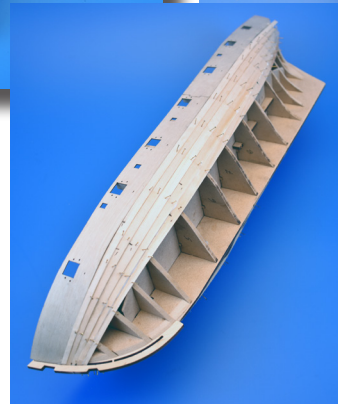
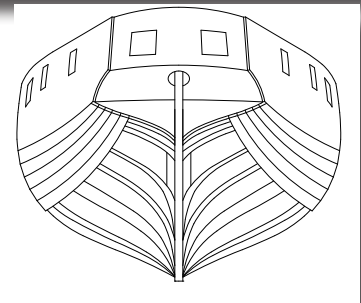

**Above** - Front tapering marked out. Note the arrows on the left and right hand planks. These are to indicate forward, as the stern is also tapered on some planks.



**Left** - Cutting the wet plank, scoring several times instead of one deep cut.

**Below** - A pair of port and starboard (left and right) planks tapered, ready to be pinned and glued to the hull frames. Note the extra markings indicating the front of the planks.

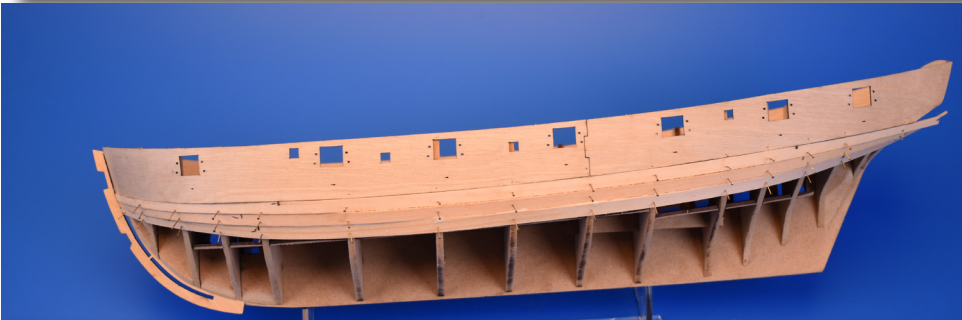

The first three planks glued and temporarily pinned in place. Note the pins pushed only half way in, so they can be easily removed once the glue has cured.





First planking complete. Remove all brass pins and sand the hull smooth using coarse followed by medium grit abrasive paper. A small electric sanding mouse would make the sanding quicker and easier, but be very careful at the extremities, as it is very easy to damage the stem at the front, or go too far at the stern.

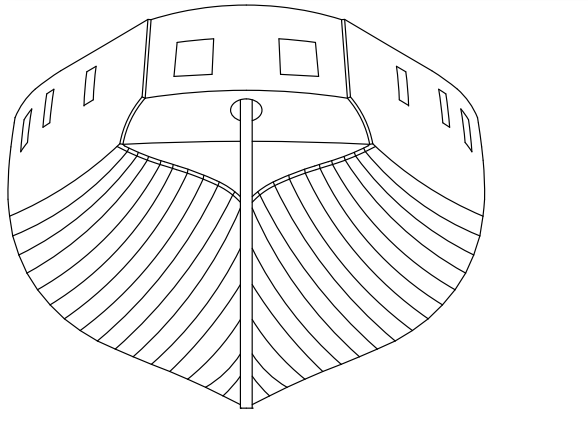

Left - When sanded smooth, trim any planks at the stern so they are all flush with the final bulkhead

Hull sanded smooth and stern planks trimmed flush. The stern post area can be sanded/filed to a thickness of 1.5mm, so that when the second planking is applied, it will sit flush with the stern post

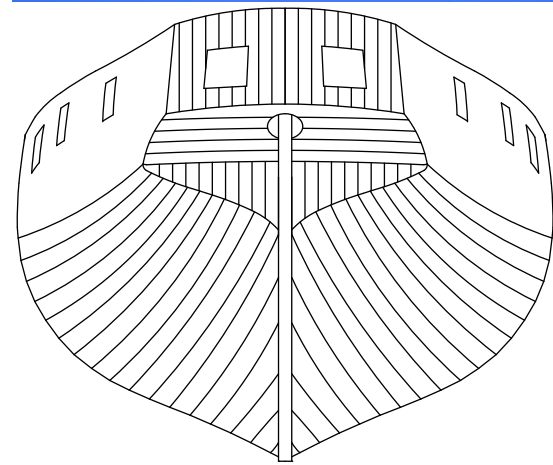
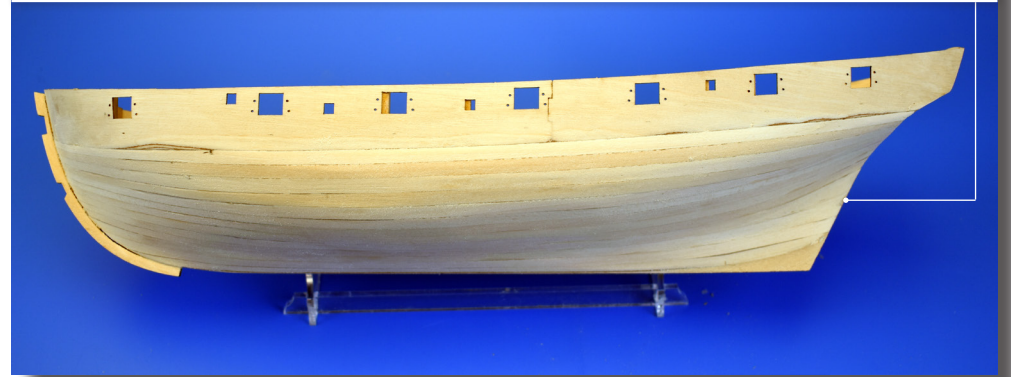

16 - Before starting the second planking, the stern areas need to be planked. Using the second planking strips, start at the lowest part on the final bulkhead and work up to the stern counter and finally the stern board. Lay the planking in the orientations shown in the drawing left. Trim off any excess, ready for the second planking.

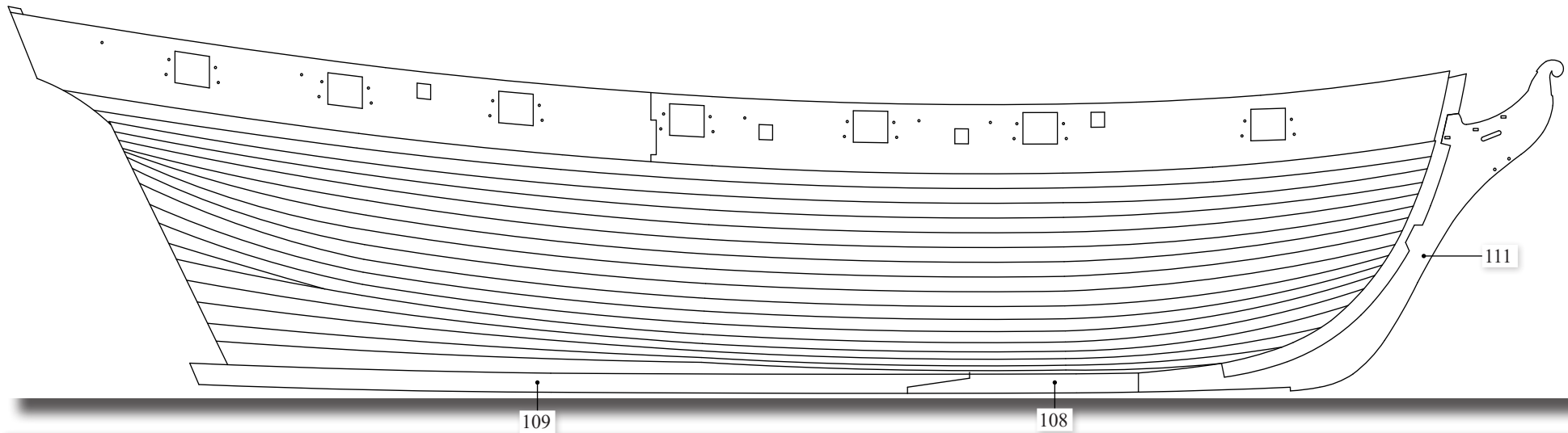

Optional - The construction pictures show the second planking applied before adding the prow and keel parts (111, 108 and 109). However, these parts can be added before second planking commences. If you choose to add these parts at this stage, great care needs to be taken when moving the hull around when planking, as the prow (111) could be easily damaged.

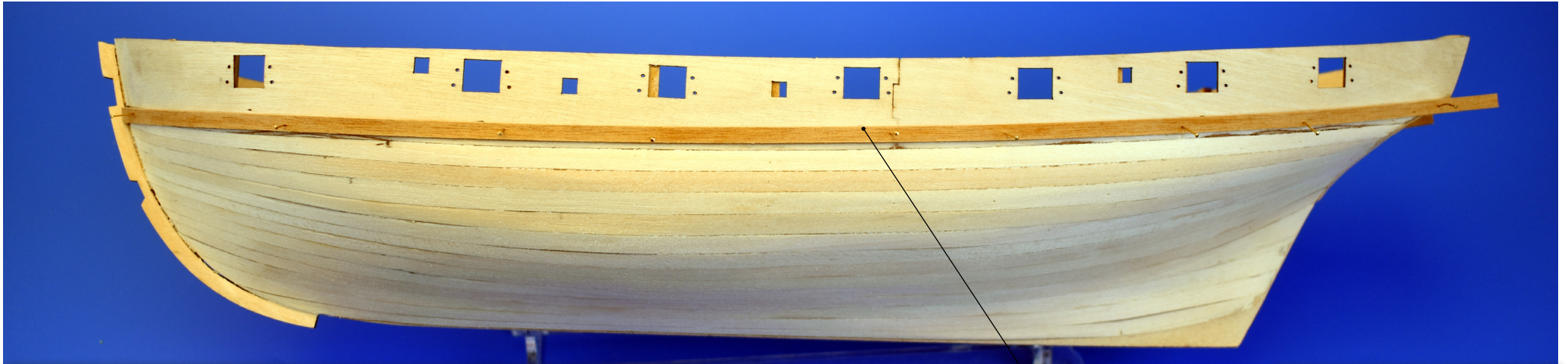

### 17 - Second Planking

The second planking is applied using 1mm x 4mm wood strip. Start planking at the main wale position markings, which are shown on the gun port patterns and work down towards and up to the keel. Use the same planking techniques as the first planking, with the exception that the whole under surface of the plank is to be glued to the first planking, as well as edge to edge.

The best glue to use for the second planking is medium to thick cyano gel. This is to avoid any pin holes showing in the planks.

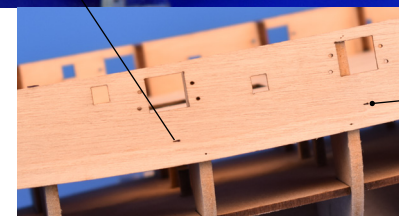

Use the small markers on the 0.8mm ply gun port patterns to correctly position the first plank. The markers indicate the top position of the main wale. Lay the first plank so that the top edge of the plank touches the laser cut lines.



Take your time and take care to attain a very neat finish to minimise the need for filling. If slight filling is required, it is recommended you use a water based filler that is a good match for the colour of the second planking. Water based filler is recommended because it can be thinned down using water, which helps the filler enter even the smallest gaps.

As with the first planking, leave the stern planks a little longer than they should be and trim and sand flush with the stern planking once complete.



The markings that were added for plank taper positions will be removed once the hull is fully sanded.



Planking complete from main wale to keel. Sand the hull semi-smooth using medium grit and then fine grit abrasive paper. Final sanding will be done once the bulwarks have been planked.

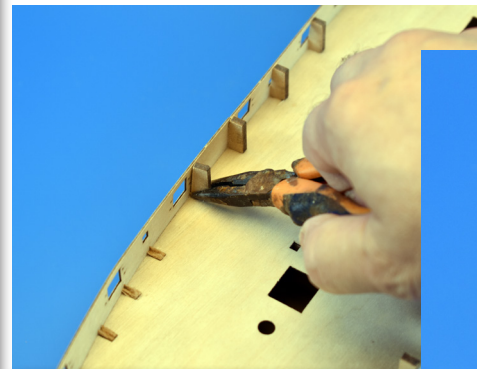
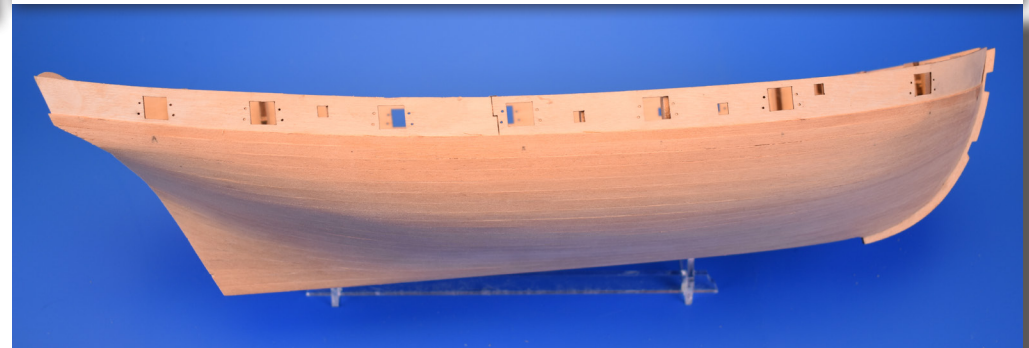

18 - Remove the exposed bulkhead tabs above deck level (Above) and then file or sand any tab remaining above deck level so they are completely flush with the deck (Right)

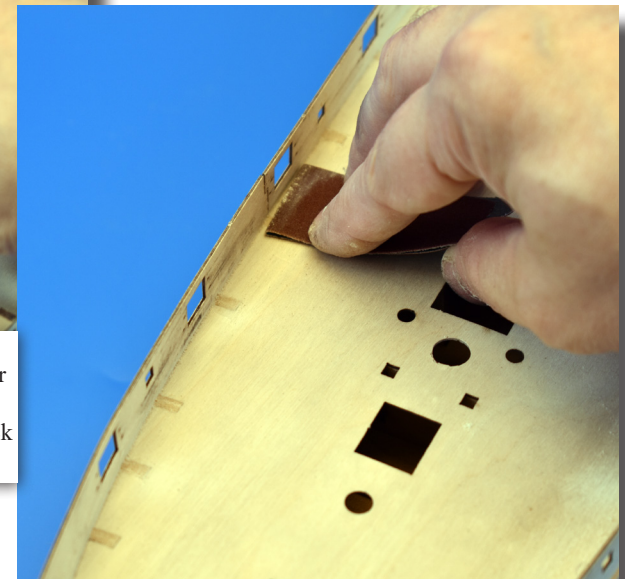





All exposed bulkhead tabs removed and sanded flush with the deck, ready for the laser engraved deck.

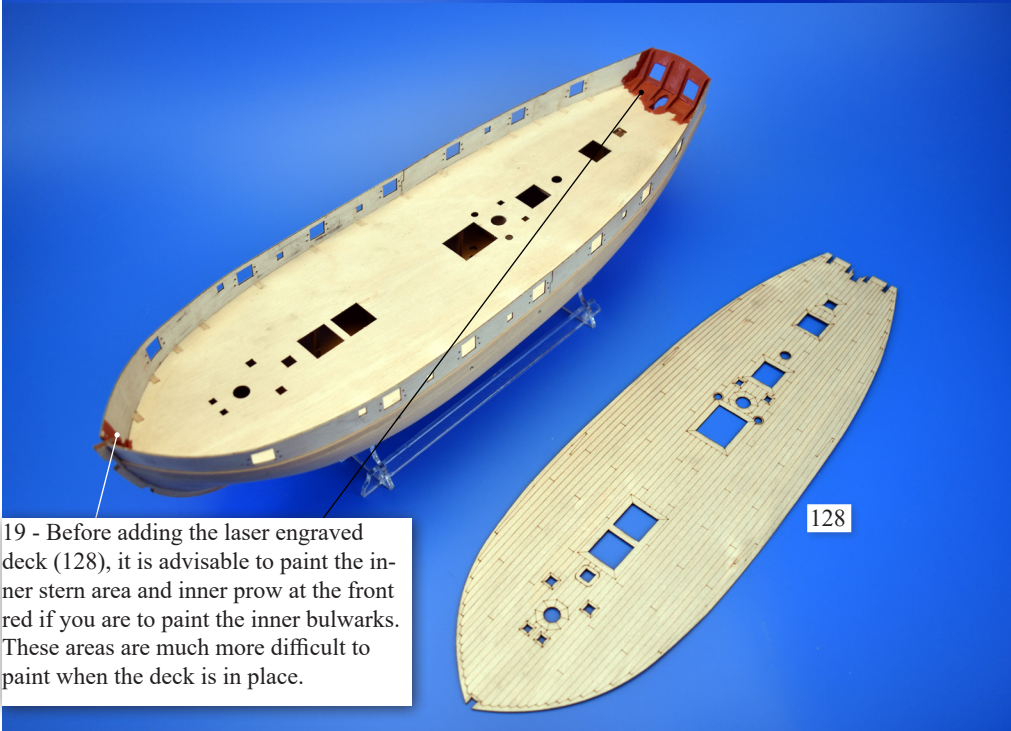

19 - Before adding the laser engraved deck (128), it is advisable to paint the inner stern area and inner prow at the front red if you are to paint the inner bulwarks. These areas are much more difficult to paint when the deck is in place.

128

20 - Dry fit the deck (128) before committing to glue. Sand any edges that may not fit perfectly. It does not matter so much if the deck edges are slightly short of the bulwark edges as the inner bulwark planking will hide any slight gaps. Once the deck fits as it should, use PVA wood glue to fix the deck in place, plus a few brass pins along the near edges to ensure the deck sits flush with the false deck.





### 21- Inner bulwark planking.

The inner bulwark planking is the same 1x4mm strip as the outer second planking. The plank nearest the deck can be painted inner bulwark colour before applying to avoid any paint coming onto the laser engraved deck.

For the prototype model, the planks were split in two so that the front and stern could fit snugly against the bow and stern extremities.

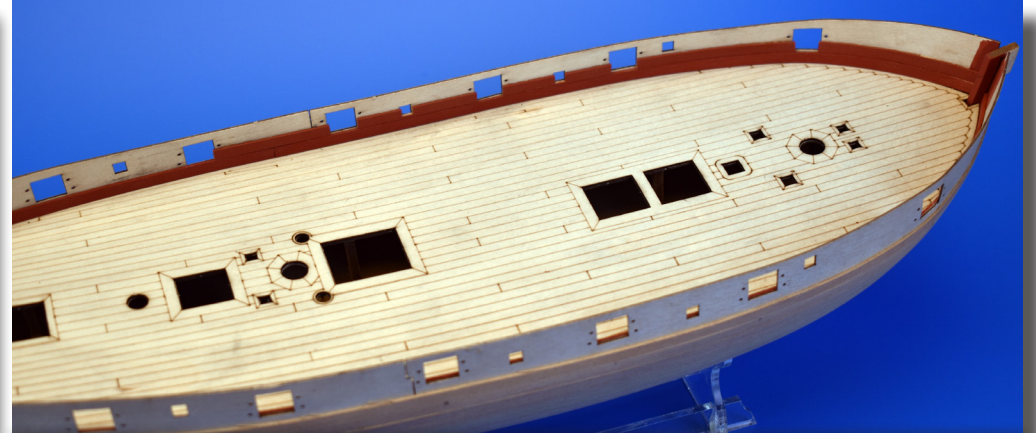
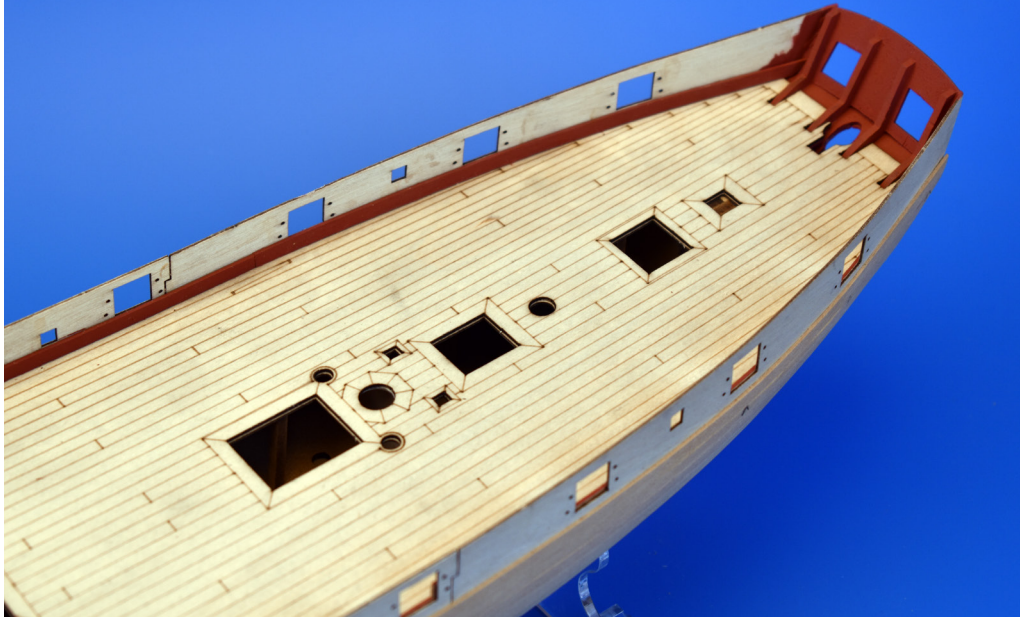

Continue planking upwards, leaving gaps in between the gun and oar ports. These can be filed and trimmed after planking the inner bulwarks is complete. Once the top is reached, trim the top of the inner bulwark planking level with the top edge of the bulwarks

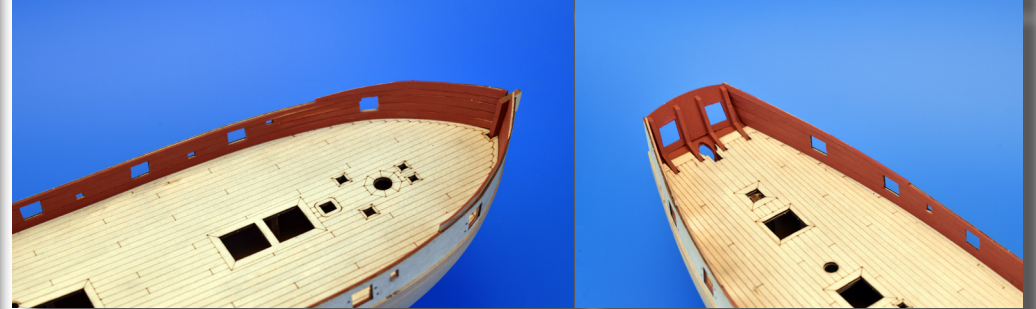
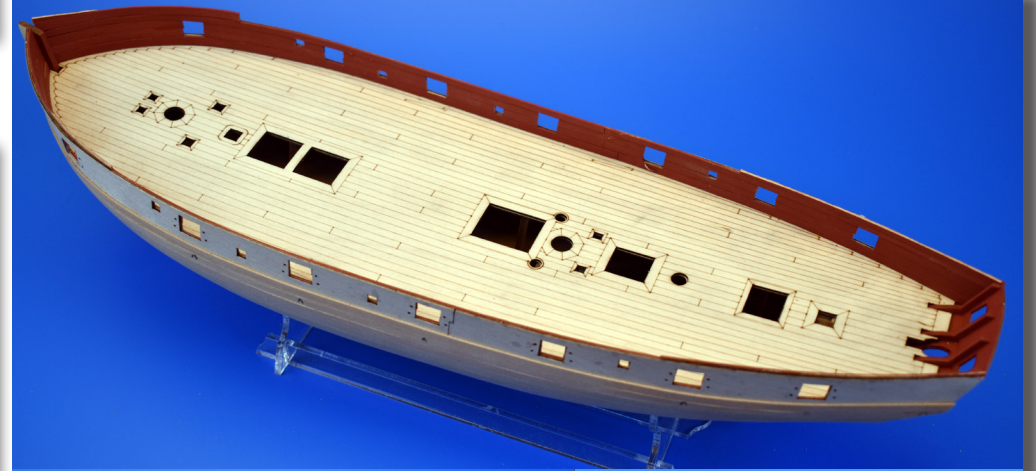

22 - It is strongly advisable to completely mask off the laser engraved deck at this stage to protect the surface. Once masked, the gun port and oar port openings can be filed to size and the inner bulwark planking can be sanded flush and re painted.

Using a small electric drill or pin vice, carefully drill out the 0.8mm diameter holes in the 0.8mm ply gun port patterns through to the inner bulwark planking. These holes are for the gun tackle eyebolts and bulwark cleat positions.

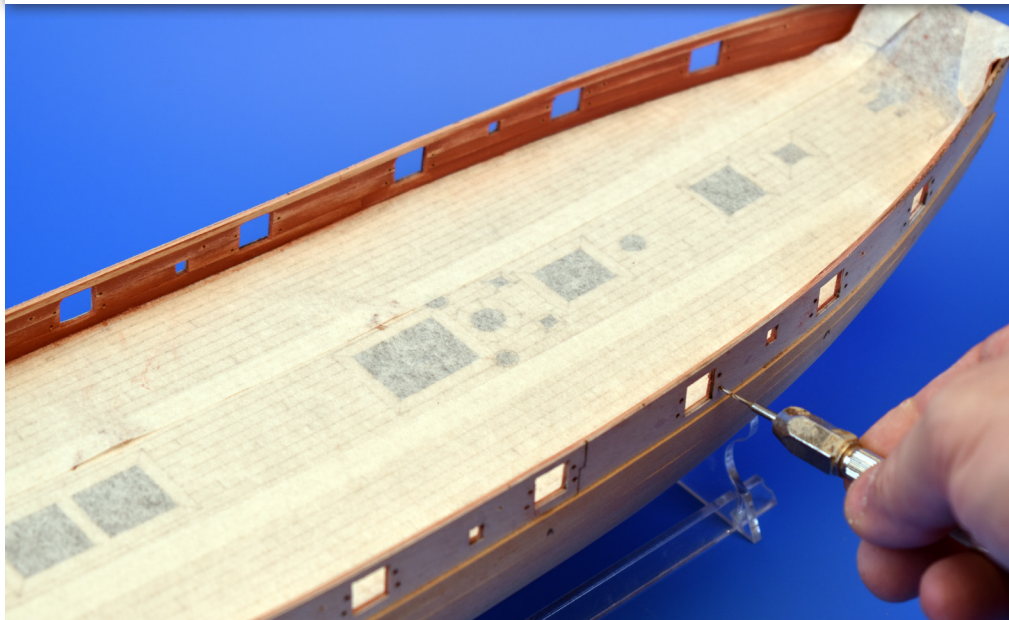

Top edge of main wale marked onto hull before the second stage of the second planking commenced.



Hull is now fully planked and more markings for the main wale added, using the top edge of the first plank laid as reference

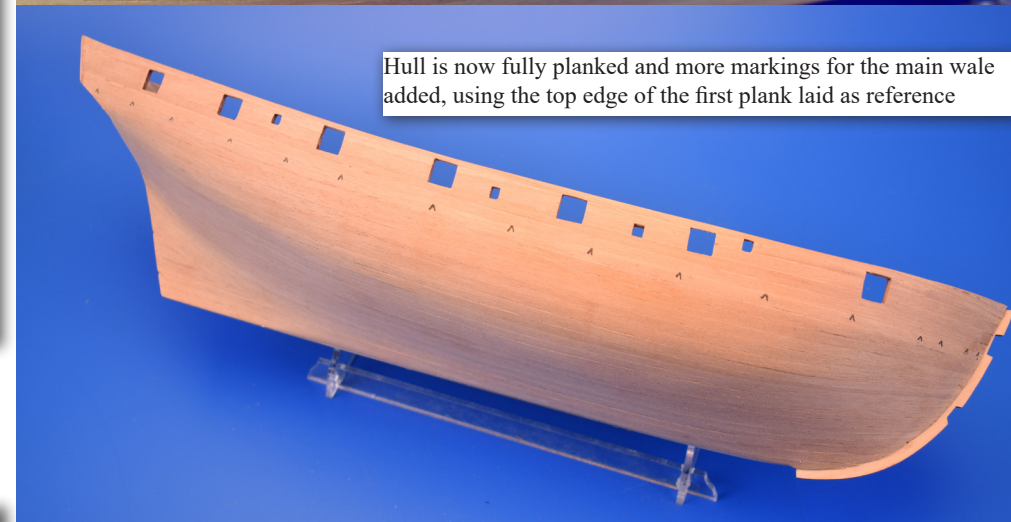

23 - Once all holes have been drilled through to the inner bulwark planking, the outer hull planking can be finished off. As with the inner planking, leave gaps for the gun and oar ports. Plank the hull until the top is reached and sand or file any excess at the rear and at the top of the bulwarks.

The markings on the hull indicate the top edge of the main wale position.

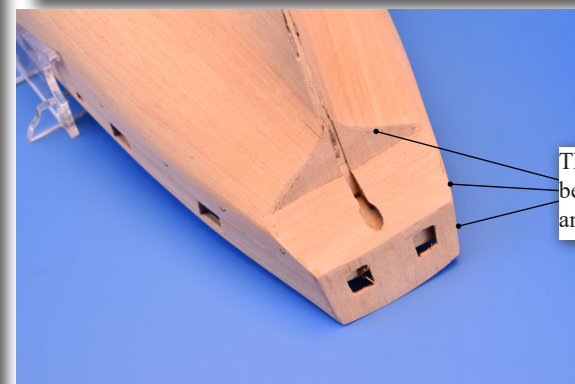
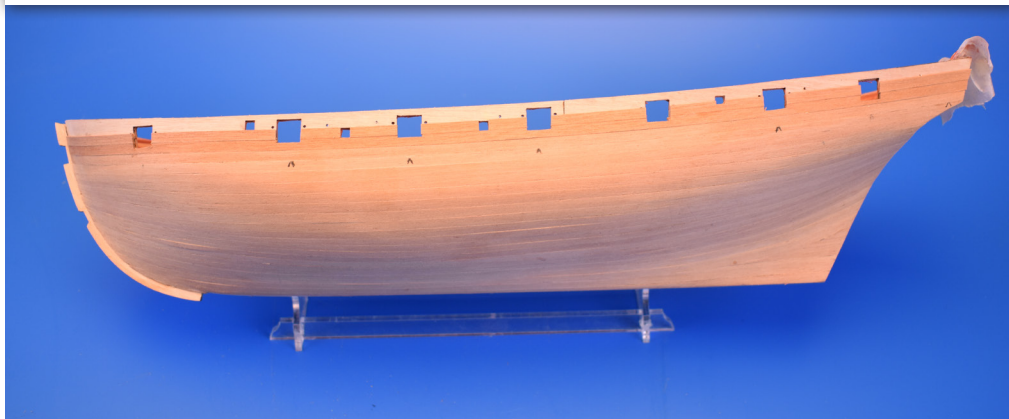

The excess planks at the stern edges have been trimmed flush with the stern planking and sanded smooth.

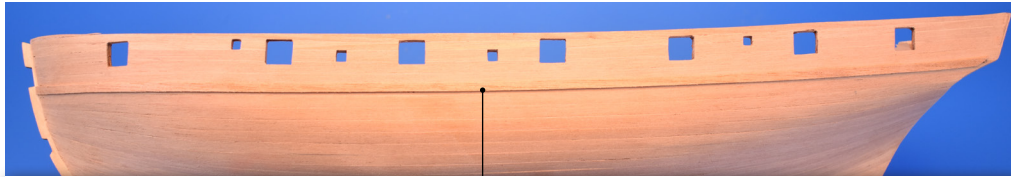

24 - using 1x3mm second planking strip, apply the upper plank of the main wale so that the top edge of the wale plank is at the same level as the top of the markings on the hull.

Cyano works well, but can be risky if plank is miss-positioned. As the wale is painted black, you could use PVA glue and pin in place and either remove the ins or cut the ends off and push them in flush with the surface of the wales.

The lower wale plank is 1x4mm second planking strip and is easier to apply as it just butts up against the lower edge of the main wale upper 1x3mm plank.

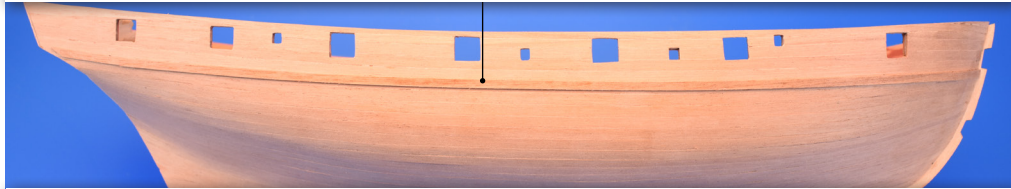

### 25 - Prow, Keel and Sternpost

If you haven't added the prow (111) and keel (108 & 109) at an earlier stage, now is the time to add them. Start with the prow (111) and carefully glue into position. Use the securing pegs (24) so that the prow remains perfectly straight in relation to the inner prow while the glue cures (PVA wood glue)

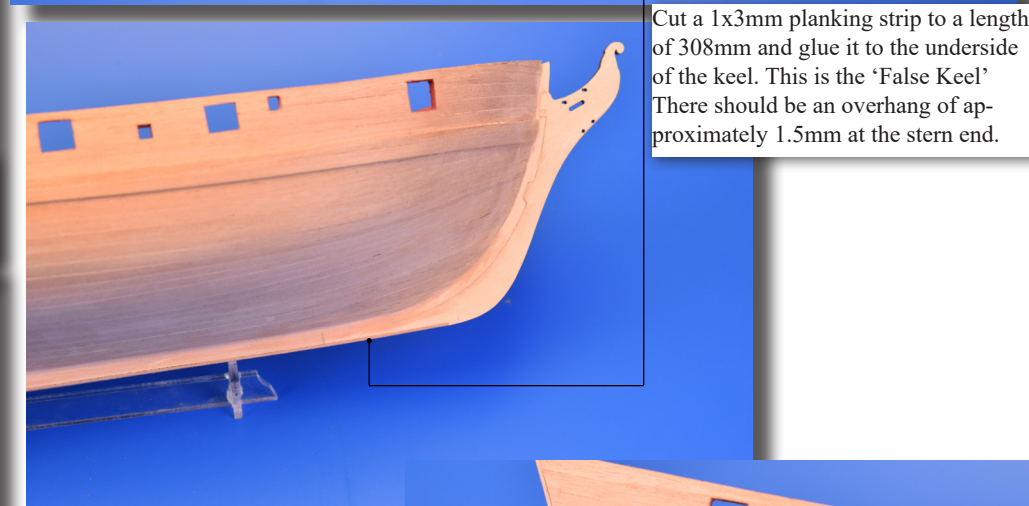
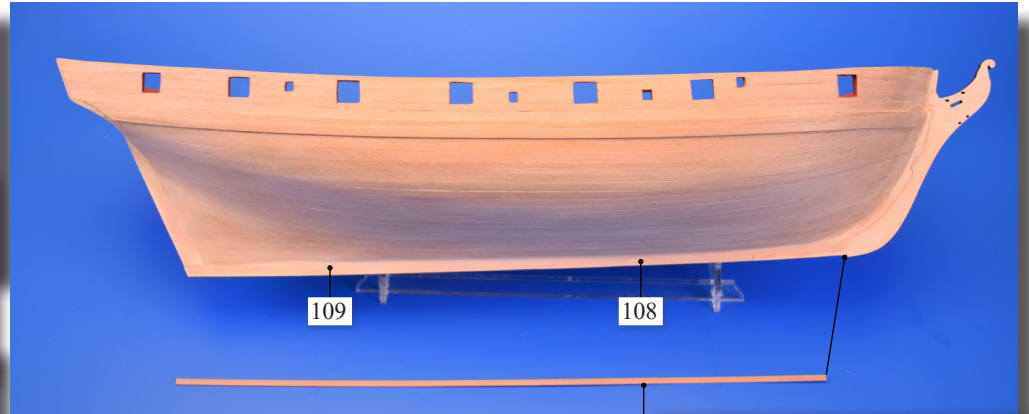
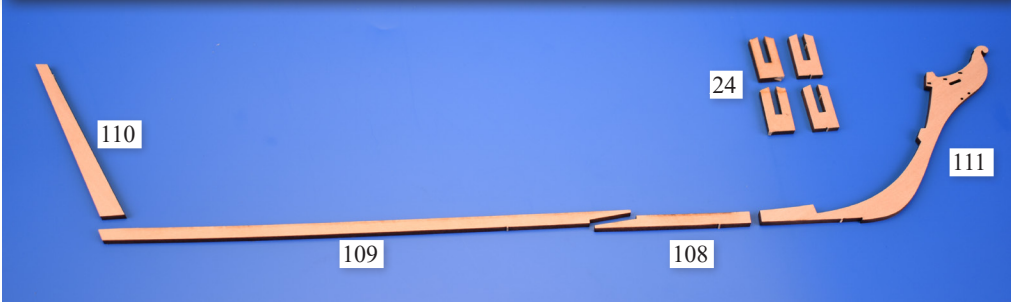

Cut a 1x3mm planking strip to a length of 308mm and glue it to the underside of the keel. This is the 'False Keel' There should be an overhang of approximately 1.5mm at the stern end.

Finally for the keel assembly, dry fit and file if necessary the rudder post (110) to the position shown. Sand the sides of the hull so the hull and rudder post are flush with one another.

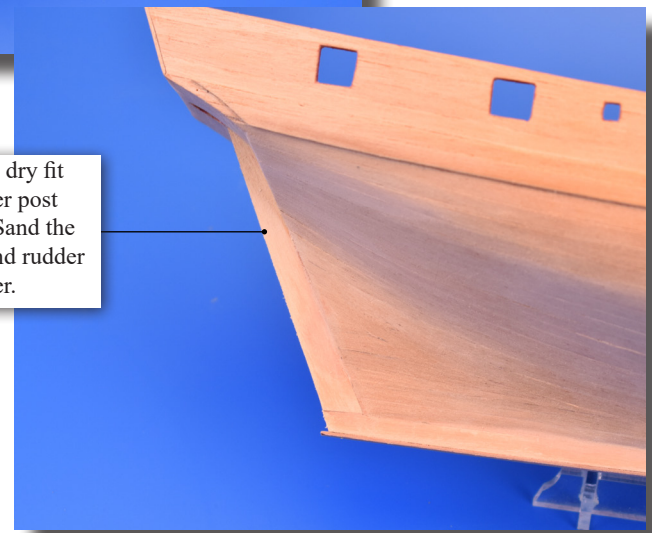

## 26 - Marking out the waterline and copper plating

Using the side profile drawing on the plans, mark out the waterline level fore and aft onto the hull and carefully mark out the waterline using a specialised waterline marker tool or similar.

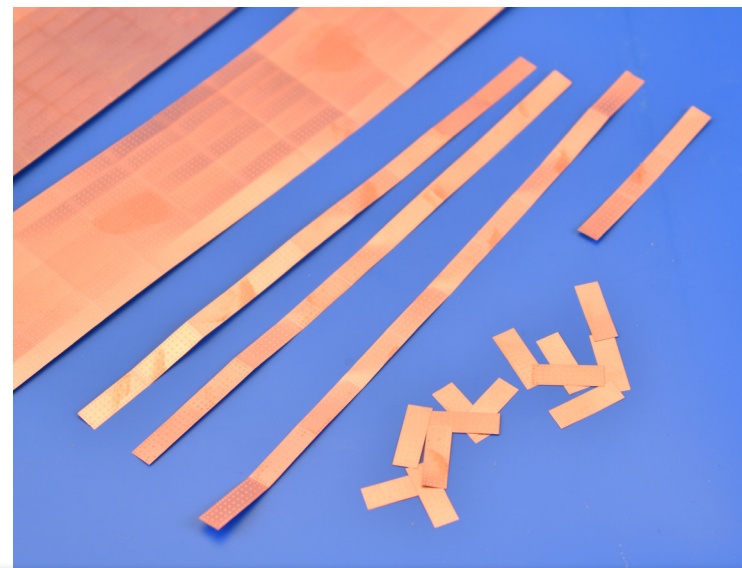

Break up the copper plates (PE-74) and start coppering from the keel upwards. Each tier should be laid 'Brick fashion'. That is, each line of plates should be staggered by half the length of the plate below. Start each row from back to front and work upwards until the waterline is reached. As the hull will need to be laid on its side whilst coppering, it is suggested that the hull should be laid on a soft surface to avoid the hull planking being damaged. Use only a minimal amount of glue dabbed in the centre of each plate for fixing in place. Apply each plate to the hull with the aid of a pair of tweezers, carefully laying the plate in place. This will spread the glue to most of the underside of the plate and hull surface. Use too much glue, and it will seep from the edges and will need to be wiped off.

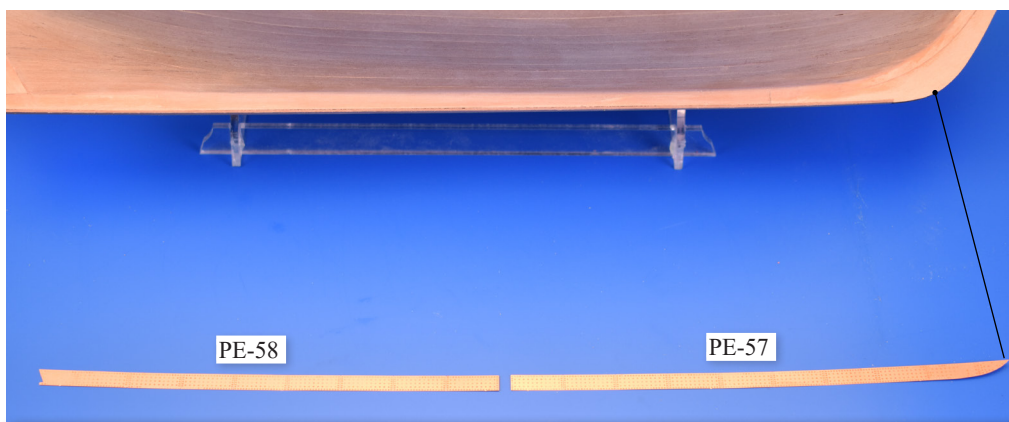

The coppering starts at the keel. Using thick cyano glue, carefully glue the photo etched copper keel patterns to the keel. PE-57 and 58 for the right side and PE-59 and 60 for the left side.

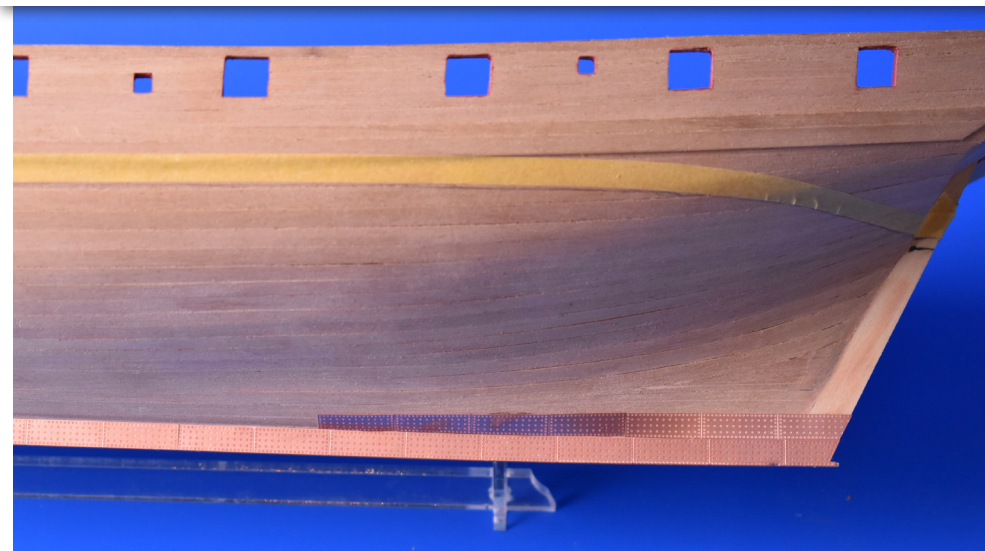

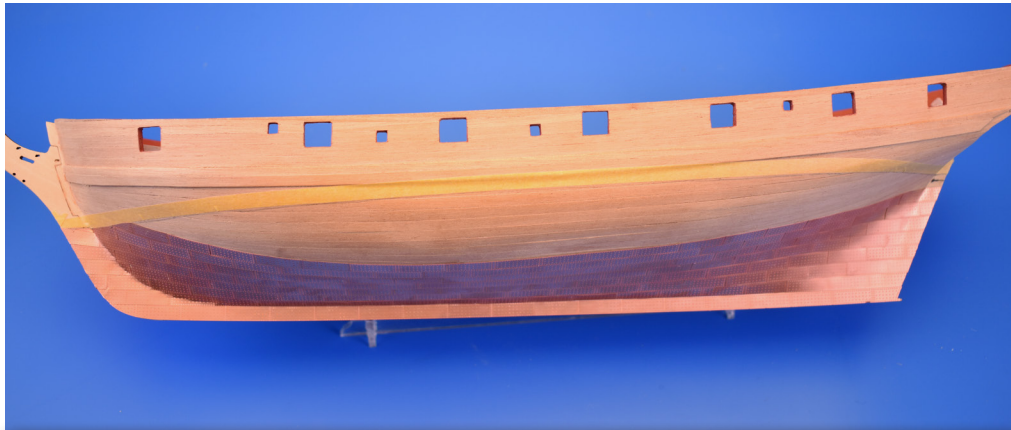

As the coppering progresses up towards the waterline, the copper plates will require trimming to the shape of the waterline level. Lay the plate in place (no glue) and mark where the plate edges intersect with the waterline level. Lay the marked plate in a hard flat surface and remove the excess using a heavy duty craft knife. Take care not to cut your fingers, as the "tapered" plates can become very sharp, always use tweezers to handle the plates. A tapered copper plate, ready for applying to the hull is shown below.

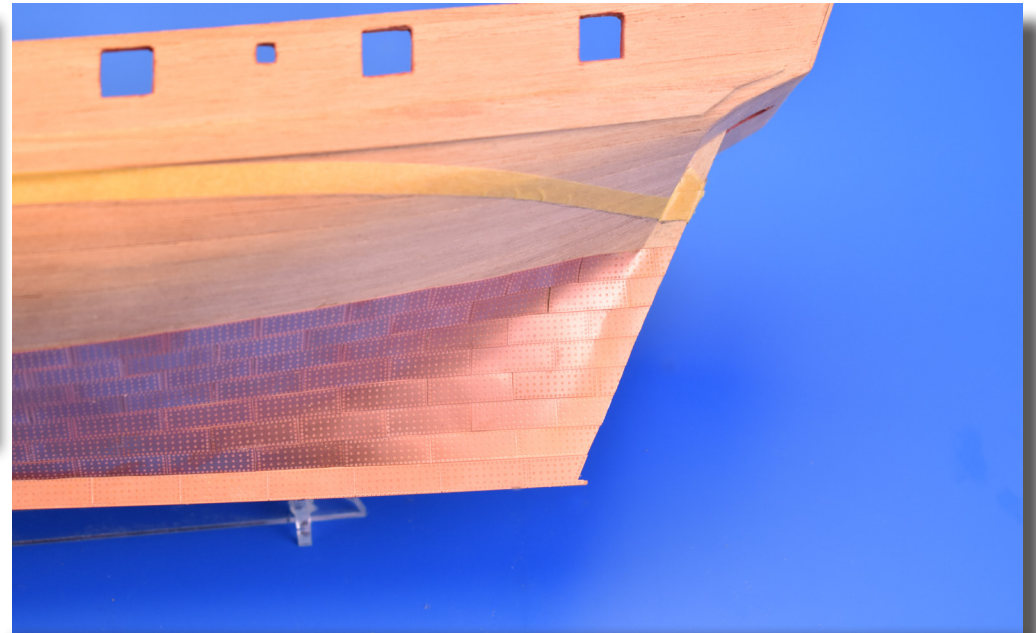
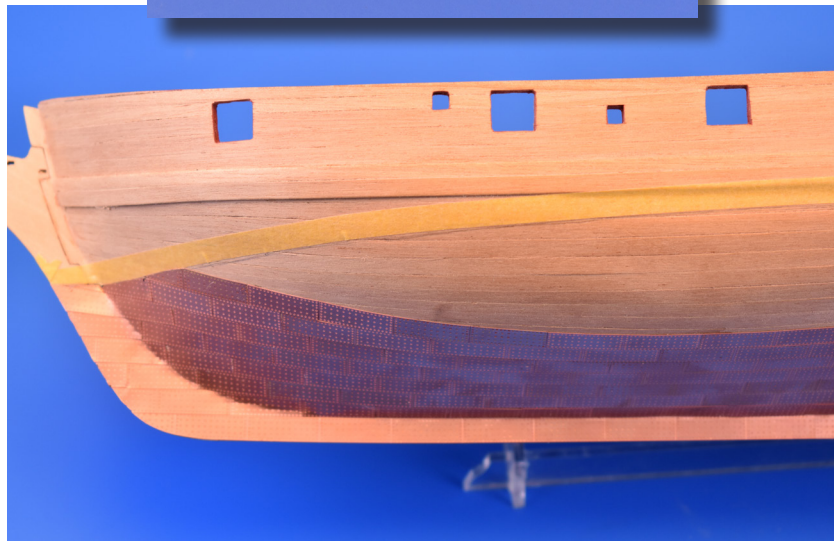
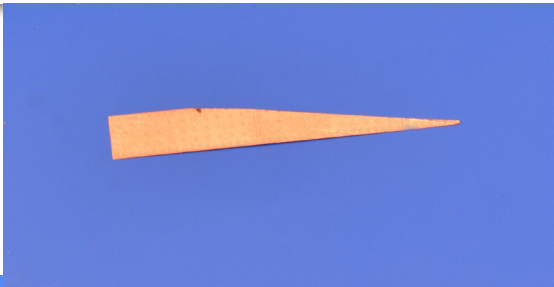

Take your time with the coppering process, and do just one side at a time, rather than coppering a line each side. Take care to wipe off any excess glue immediately using a cloth. Do not use a wet or damp cloth as using cyano glue, as moisture activates the glue and will harden almost immediately on contact.

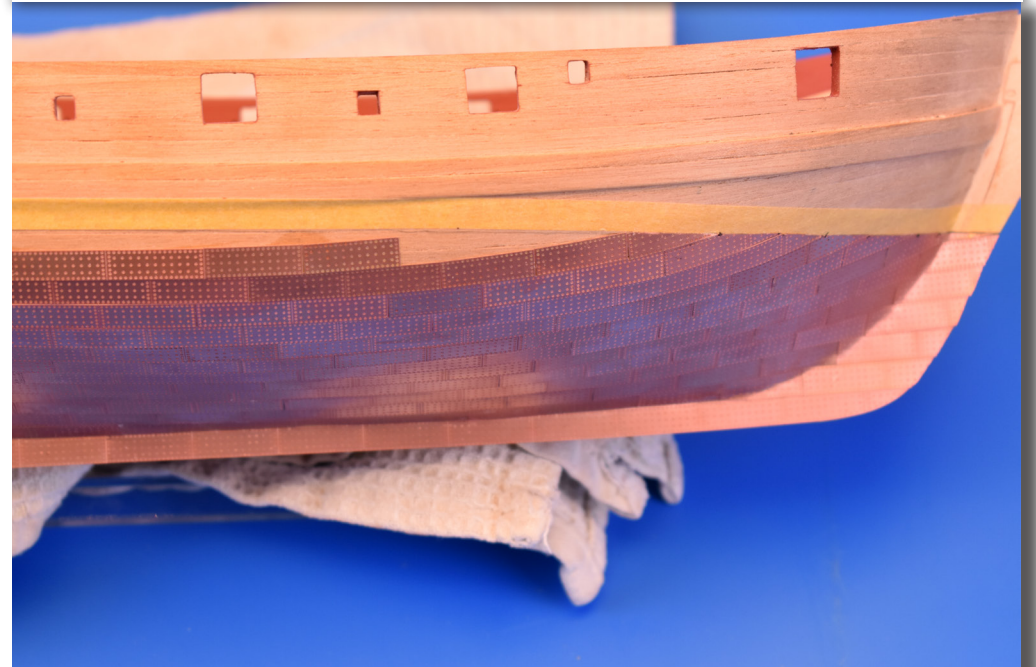

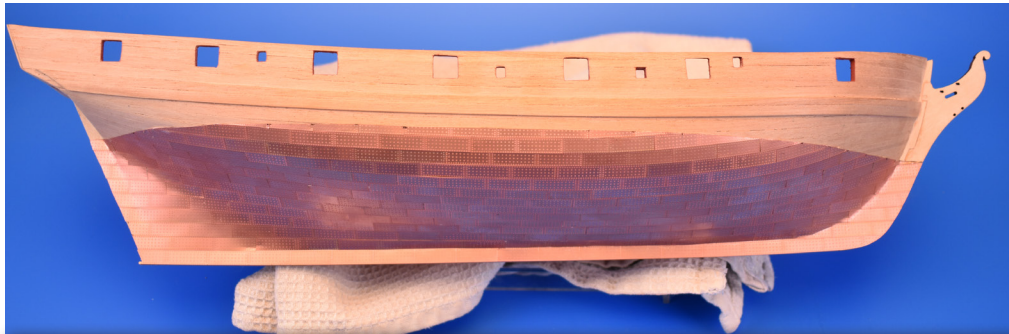

When the copping of the two sides of the hull is complete, add the copper strips to the edges of the prow and bottom edge of the keel (PE-64 & PE-63)

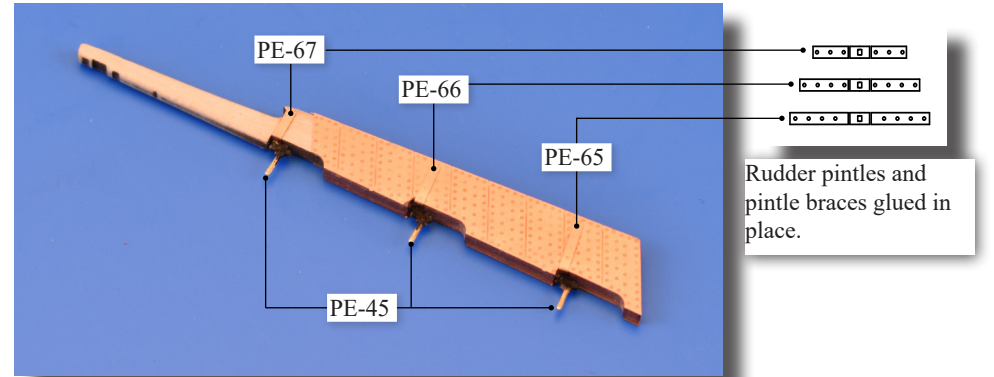
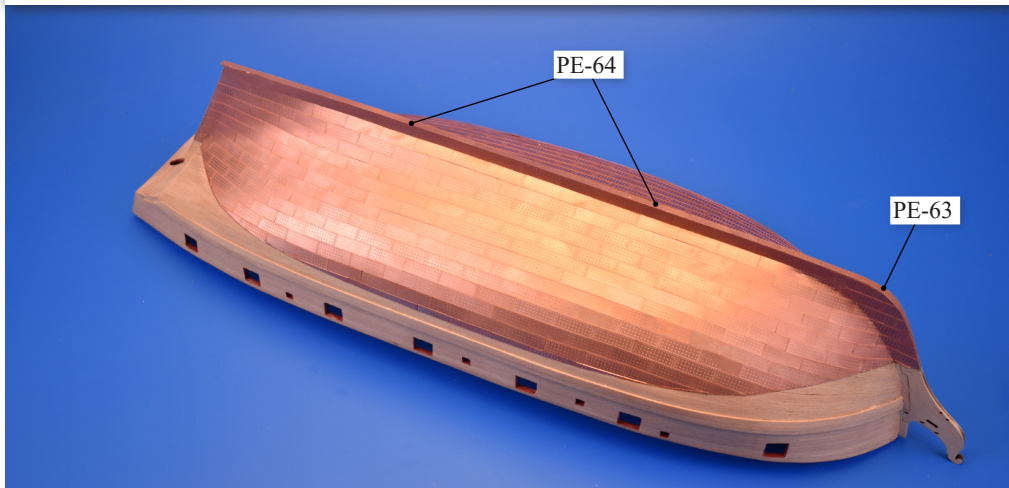

Rudder pintles and pintle braces glued in place.

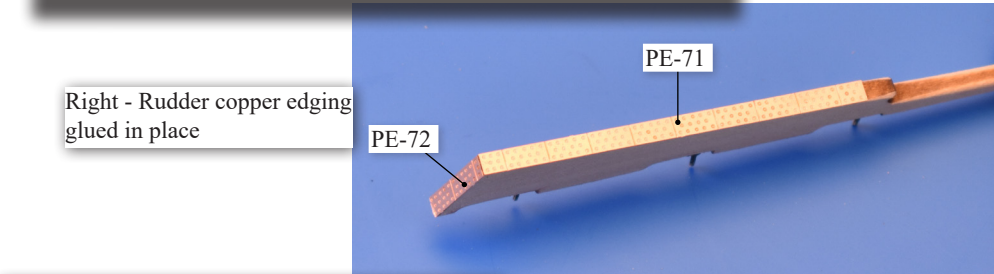

Right - Rudder copper edging glued in place

Paint the outer edge of the rudder post copper and then mark out and drill the three 0.8mm holes to take the pintle, to secure the rudder.

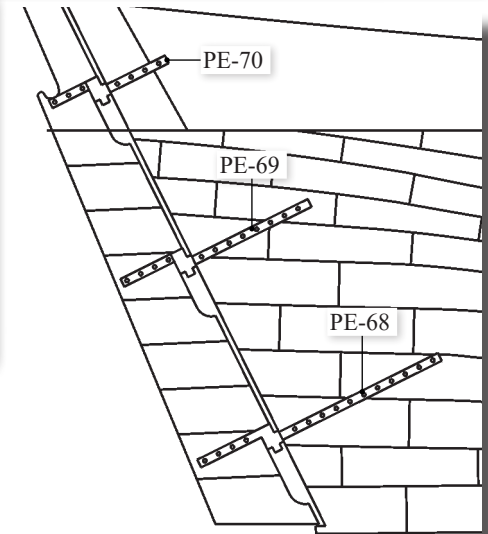
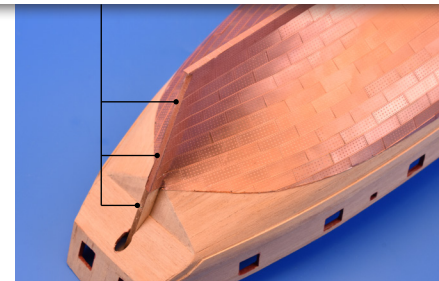

Carefully glue the rudder gudgeon braces (PE-68, 69 & 70) into position either side of the rudder post to the positions shown above. Temporarily fix the rudder in place to gauge the correct positioning.

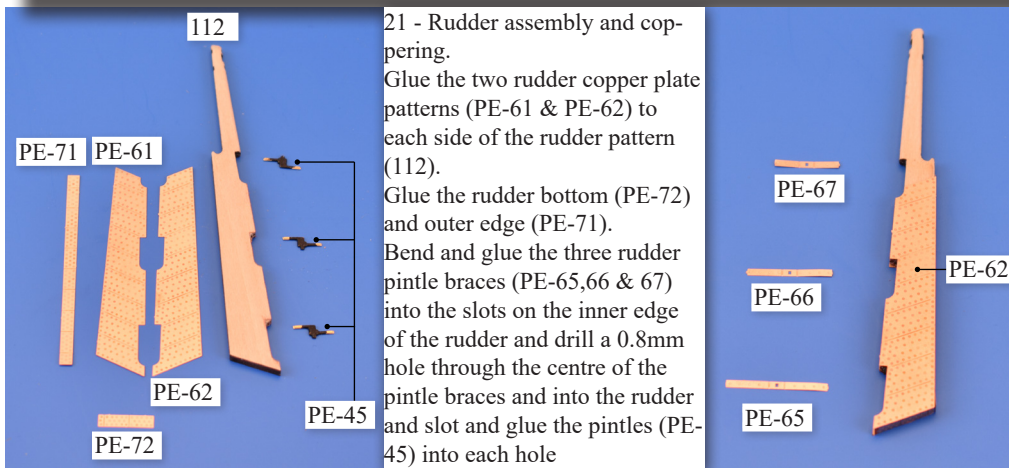

21 - Rudder assembly and copping.  
 Glue the two rudder copper plate patterns (PE-61 & PE-62) to each side of the rudder pattern (112).  
 Glue the rudder bottom (PE-72) and outer edge (PE-71).  
 Bend and glue the three rudder pintle braces (PE-65,66 & 67) into the slots on the inner edge of the rudder and drill a 0.8mm hole through the centre of the pintle braces and into the rudder and slot and glue the pintles (PE-45) into each hole

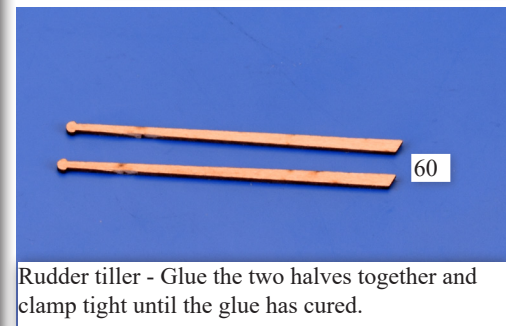

Rudder tiller - Glue the two halves together and clamp tight until the glue has cured.

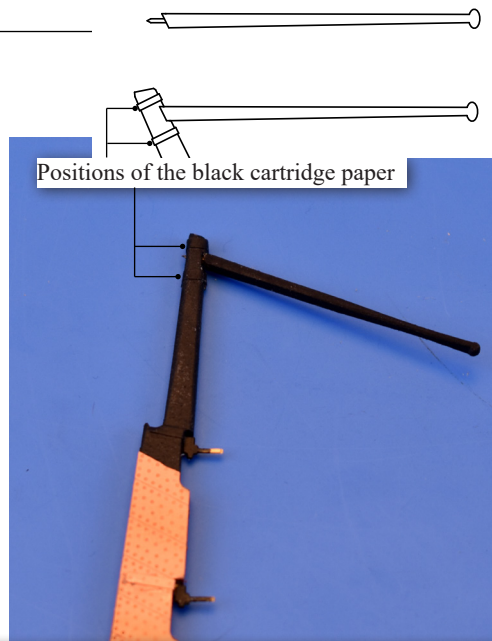

Above - The rudder above the copper plating is painted black, as is the tiller arm. A small pin has been inserted into the end of the tiller arm to help secure it to the rudder head. Cut a length of black cartridge paper to a width of approximately 1.5mm and glue and wrap a length around the upper and lower positions of the tiller on the rudder head.

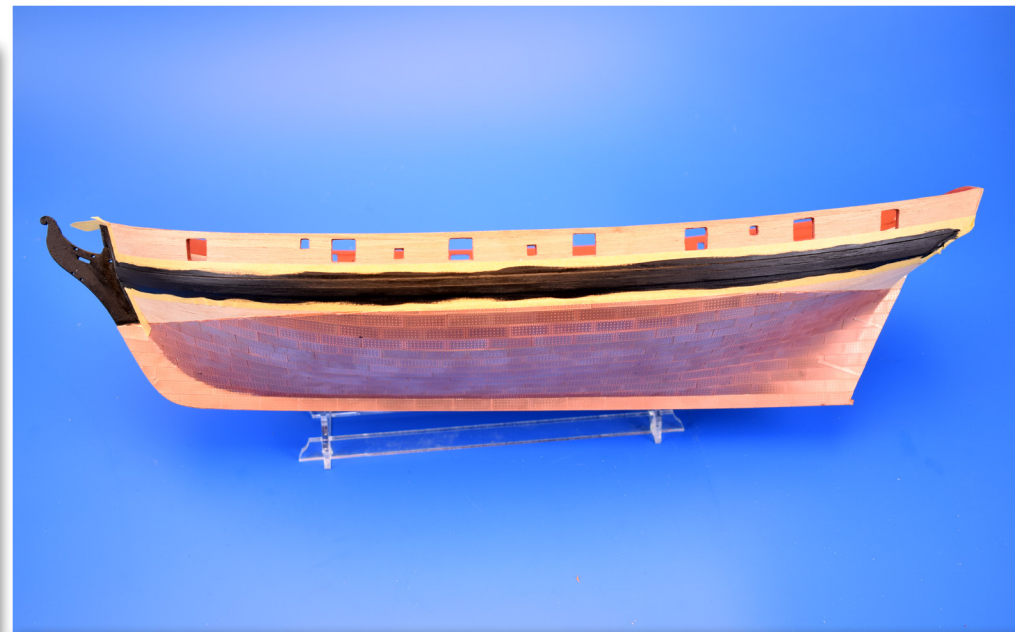

22 - mask off the prow and main wales areas and paint these black. A few coats with sanding and filling may be needed to achieve a smooth surface without any slight gaps in between the two wale planks. Sand the prow in between coats also, to help tone down the grain on the wood surface. At this scale, the finish needs to be as smooth as possible.

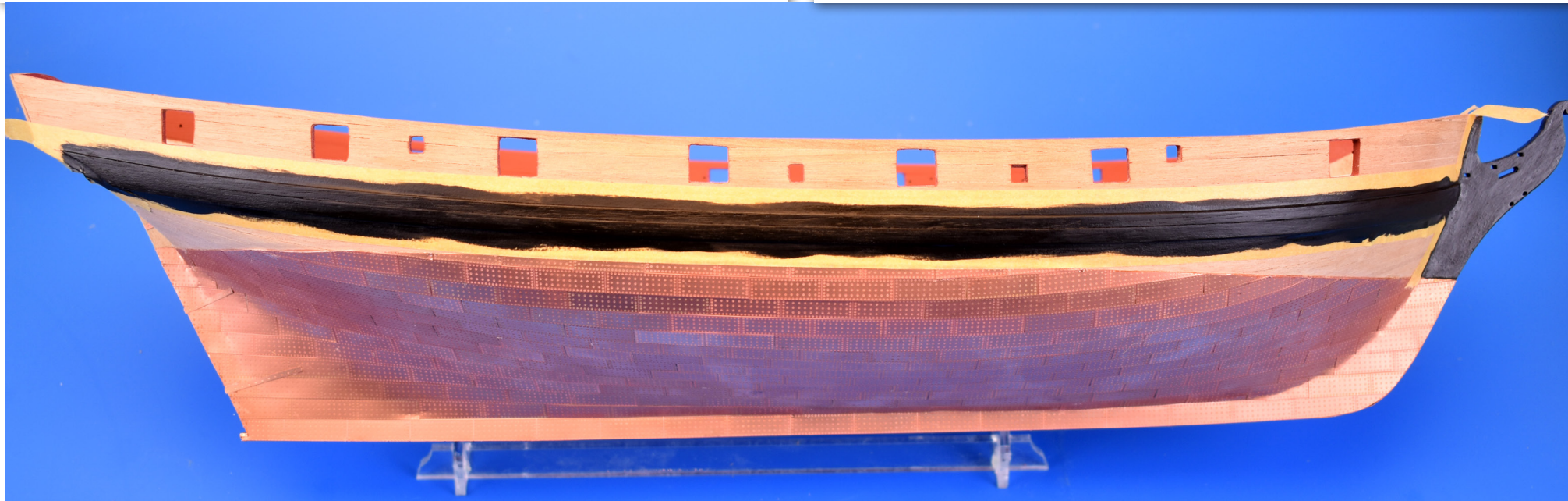



### 23 - Bow fittings 1

A - Hair brackets (45). Remove the 0.8mm ply parts (45) and carefully glue each side in place. They are to be painted black.

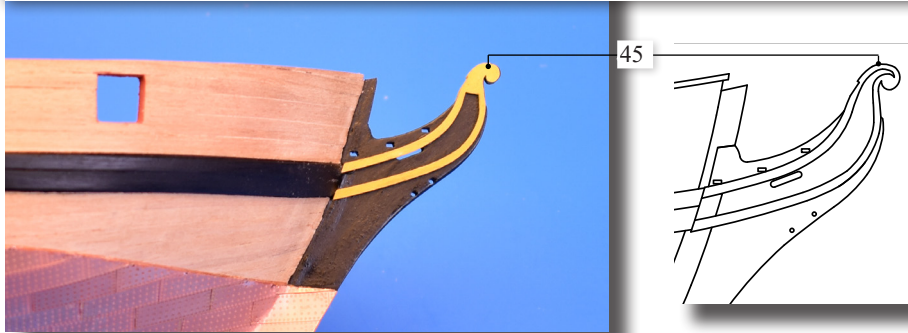

B - Bow cheeks (78). Remove the 4 laser cut wood parts (78) and carefully file/sand a bevel into the hull and prow contact areas, so they fit flush but angled correctly. Please note - Parts 45 are painted yellow in the photos only to help highlight the correct positioning of the bow cheeks.

The positioning of the pair of cheeks each side should be quite straight forward, as the upper cheek located near the top of the forward main wale, and lower cheek locates near the bottom, with the prow surface matching the angle of the hair brackets.

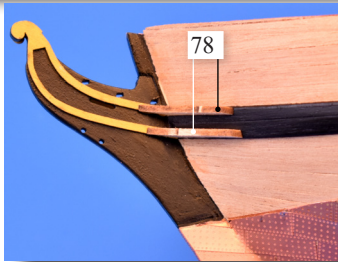
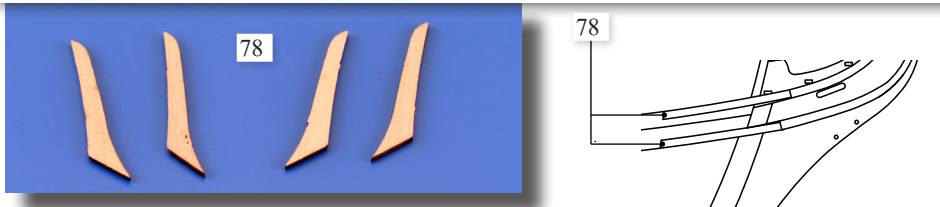

When glued into position, mask off if necessary and paint the hair brackets and bow cheeks black.

C - Hawse bolsters (64). Dry fit and sand if required in order to make each side fit as it should. Paint black and glue into the position shown. Using a 2mm diameter drill bitt, carefully drill out the hawse holes as the semi-circular positions in the hawse bolsters

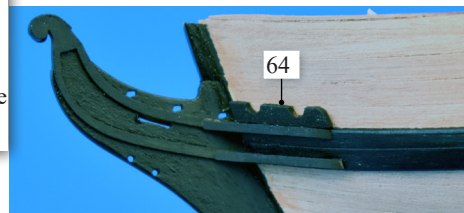

### 24- Capping and side rail/swivel gun posts

Paint black and fit the capping rail in place (53 & 53a). use PVA wood glue and pins at regular intervals. The pin heads can then be removed and the ends pushed down flush with the capping rail top surface and then painted black.

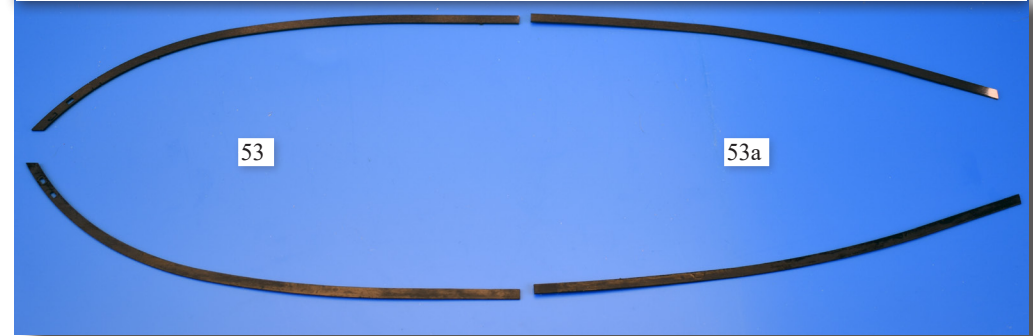

The outer edge of the capping should protrude no less than 0.8mm from the edge of the upper bulwarks. This is to ensure the pre-cut swivel gun posts sit flush with the lower edge of the lip on the underside of the capping rail patterns.

Stern counter side timbers (56). Dry fit each side of parts 56 and carefully removed the end of the main wale so that parts 56 fit onto the hull with the forward part of parts 56 butted up flush with the end of the main wale. Trim the ends of parts 56 if they protrude further out from the stern or past the lower edge of the main wale.

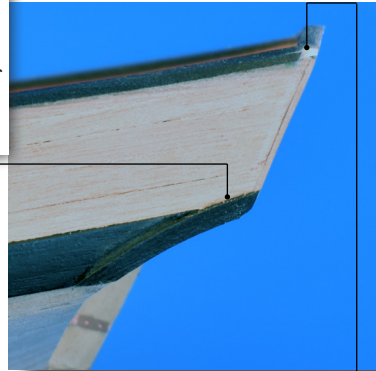
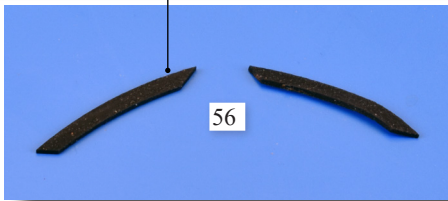

Left - Although not fitted at this stage, it is worth filing the ends of the stern capping rail so that the outer edge is flush with the hull side 3mm in from the end. This is so part 113, the boom crutch will sit flush with the side of the hull when finally fitted and glued in place, and filing this area now will ensure no other area is accidentally damaged in the filing process

Below - Cut out and paint the upper rail and swivel bun post patterns from the 0.8mm ply sheet and paint black. Number 40 is the forward-most and 44 is the after-most of the parts. The only part that requires a significant bend is part 40, as this bends around the bow area, while the rest only have the slightest of curves to fit along the hull. Each pattern has a small cut. This is for the gun port opening positions. The areas in between the gun ports are to be removed once the rails are fixed in place. This method should ensure the rails run exactly parallel with the rake/sheer of the capping rail.

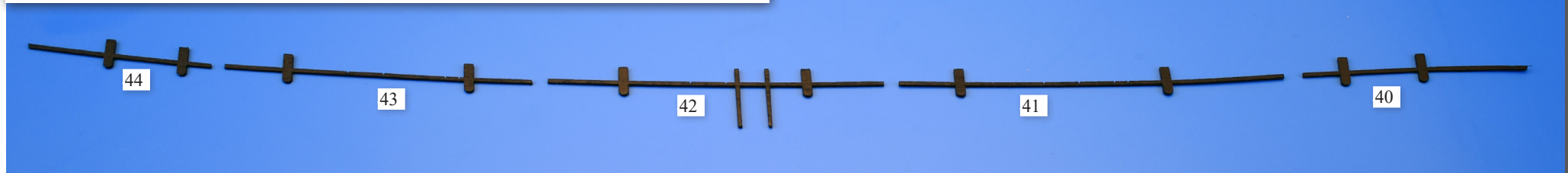

Above - Part 40 pre-shaped and glued in place. The only marking out required is the upper rail position at the prow. The rest of the rail patterns simply butt up against the lower edges of the capping rail.



Above - Part 41 glued in place. The 'notches' should correspond with the second gun port opening and first after port

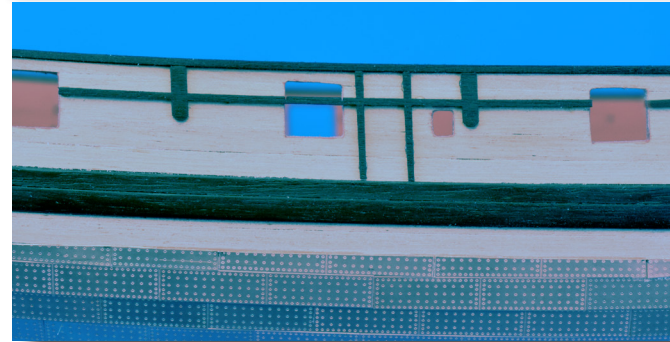

Left - Part 42 glued in place. The longer side fenders should finish near or at the top of the main wale position

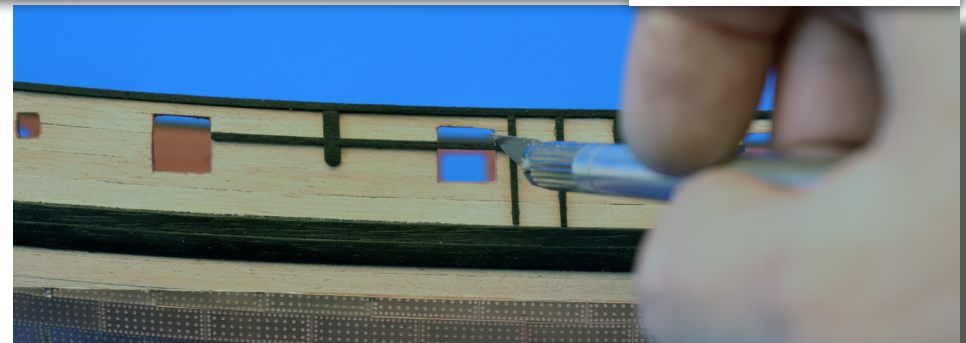

Below - Cutting off the excess rail in between the gun ports using a sharp craft knife (or side cutters would work as well) Sand or file any residual protrusion so the rail is flush with the gun port edges.

End of part 44 cut off 3mm short from back edge of stern board.

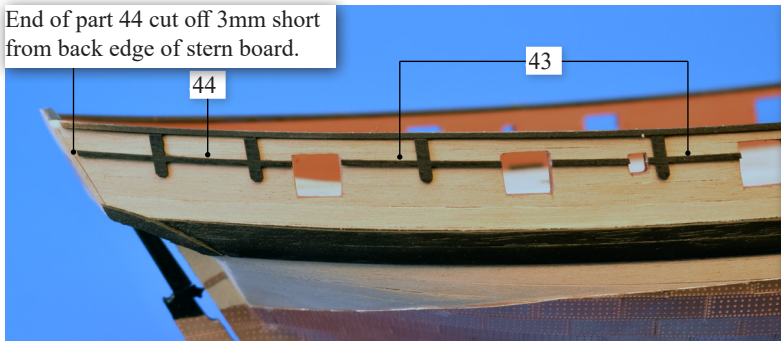

Left - Parts 43 & 44 glued in place and areas protruding the gun port openings trimmed back. At the end of the stern most rail (44), make sure it is 3mm short of the end of the stern area, so that the boom crutch fits in place.

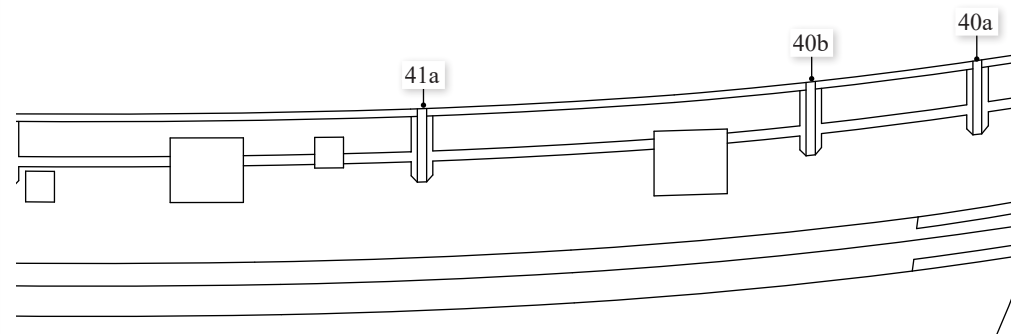

The swivel post support timbers are added at this stage. These can be painted a separate colour, like yellow ochre, for example, before fixing in place. (Fender patterns (42b) should be painted the same colour as 42). If left black, paint them first or after fixing in place. The top edges should come up flush with the top edge of the capping rail. Use tweezers to apply each part.

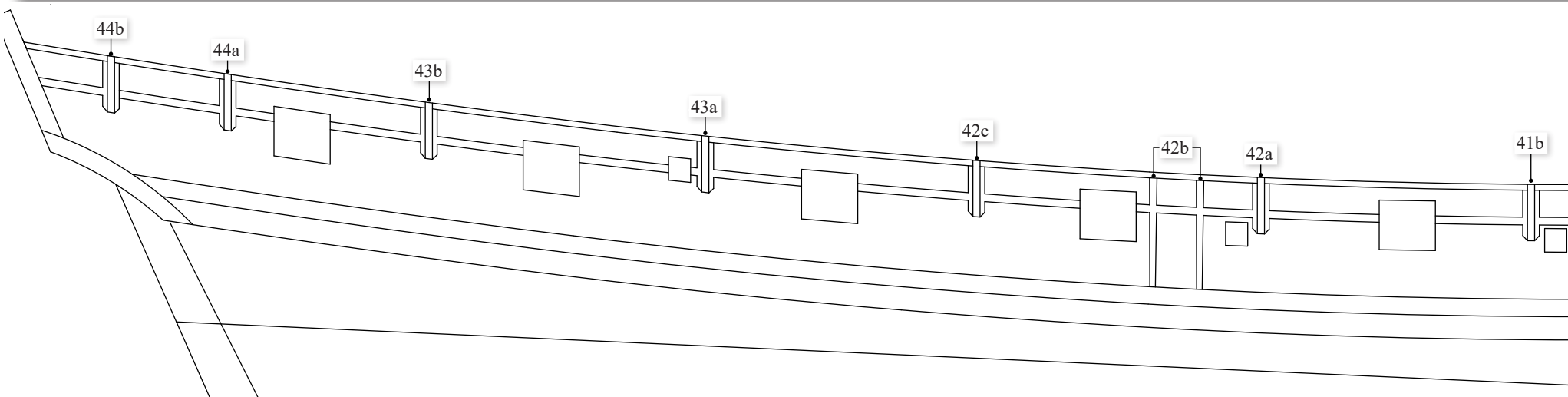
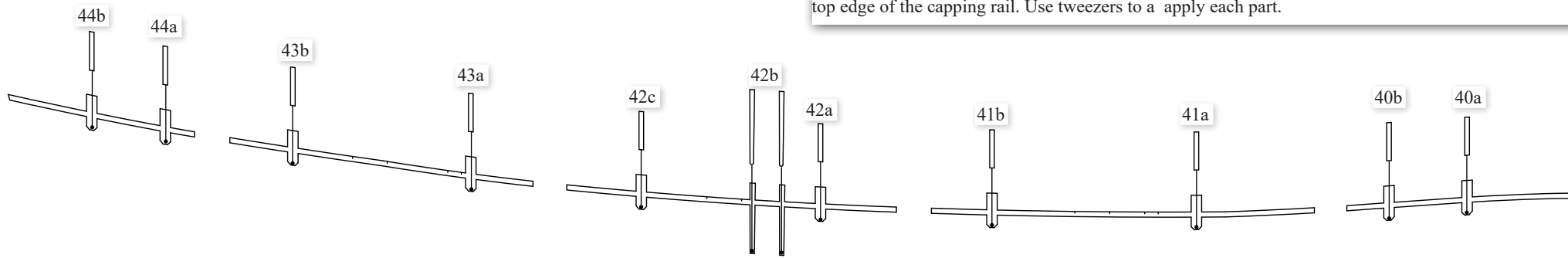

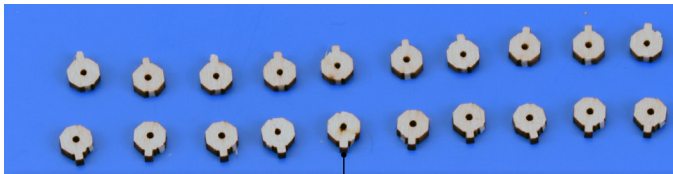

The extended end of each base fits to the top edge of the swivel gun outer posts.

#### Swivel gun bases (77)

Carefully glue each base into position on the top surface of the capping rail, directly above each swivel gun post.

When all are glue into place, drill a 0.8mm diameter hole through the base hole position through the capping rail down to about 3mm to take the pin for each swivel gun bracket.

When complete, carefully paint the parts black, including the outer swivel gun post patterns if not already painted.

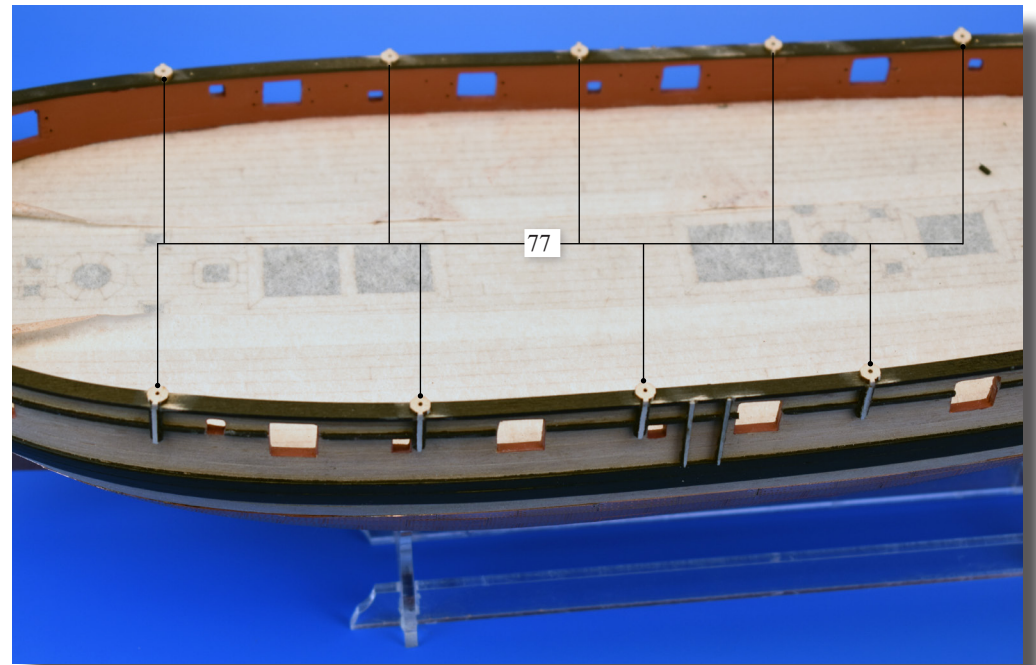
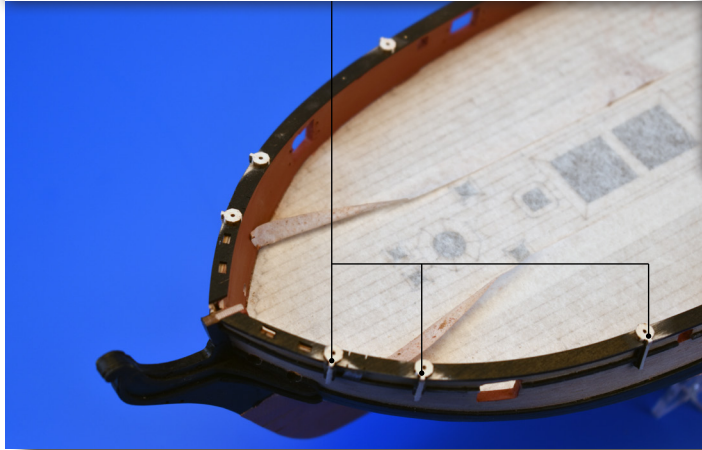

**25 - Finishing off the stern A**

Cut out and paint the three stern board rails (57, 58 & 58) black (or yellow ochre), carefully glue each in place on the outer face of the stern board. Add a length of 1x4mm planking strip to the top edge of the stern board for the capping and paint black

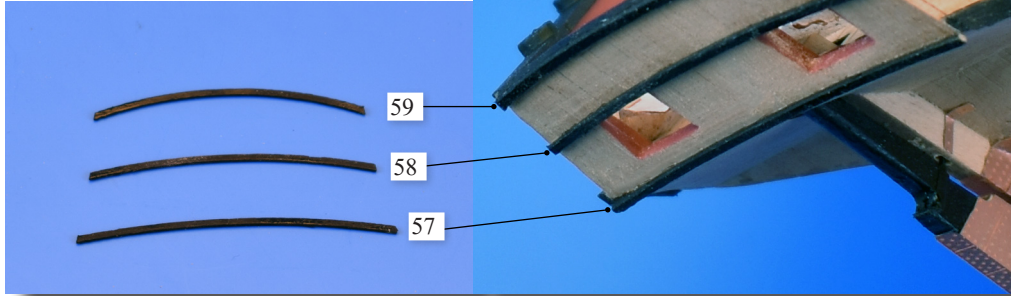

**25 - Finishing off the stern B**

Dry fit the boom crutch patterns (113) and file the ends to the correct angle that follows the top edge of the main wale. When it fits flush with the main wale, carefully glue in place to each side of the edge of the stern board.

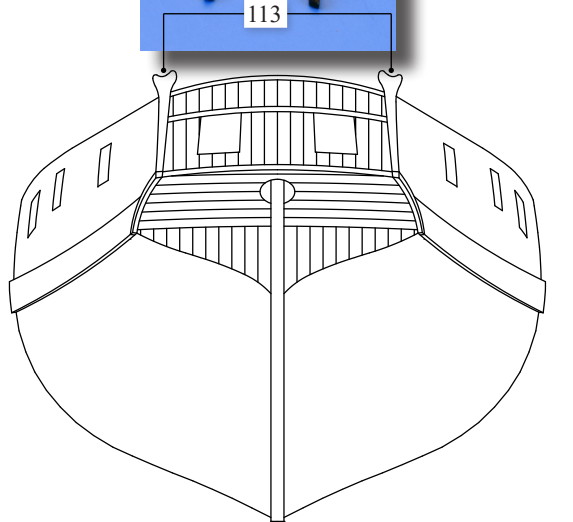

**26 - Bow fittings 2**

a - Hair bracket decoration (PE-1 & PE-2). Remove the sides from their 0.2mm photo etched sheet and paint yellow ochre. Once dry, you can use a difference colour in between the raised lips (black or blue), using a fine paint brush or, as shown, a coloured Edding-type pen (b). carefully scrape any excess paint/ink that may be on the raised lips by very lightly scraping with a craft knife (c). If you are careful, you will scrape just the paint you wish to remove and leave the yellow ochre paint intact. d & e = Dry fit each side and slightly bend the ends so they fit snugly at the junction between the hair bracket and bow cheek. Use cyano gel to fix the two side in place as shown.

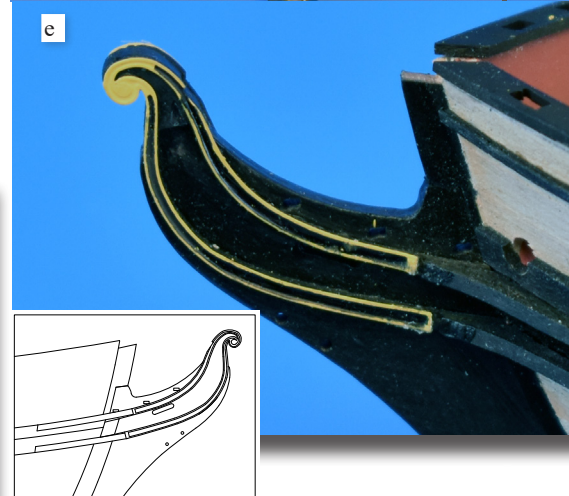
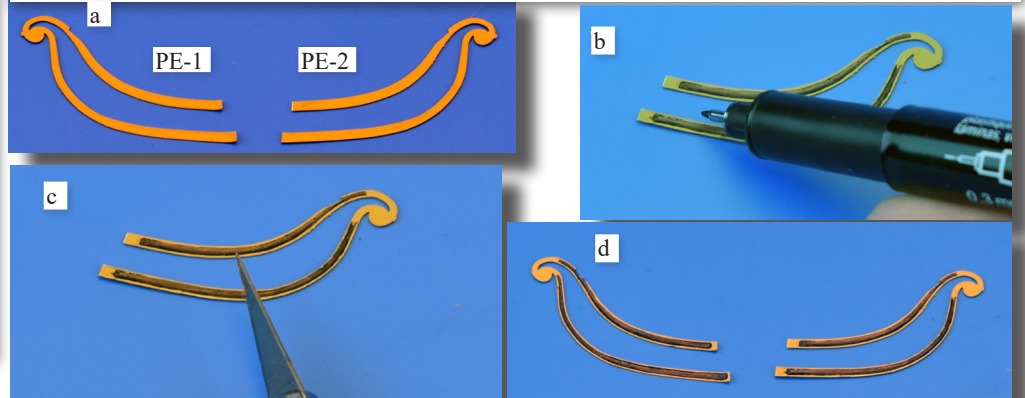

Below - Paint and details the three bow vertical rails (PE-33, 34 & 35), but paint on the yellow ochre on all sides of the parts.

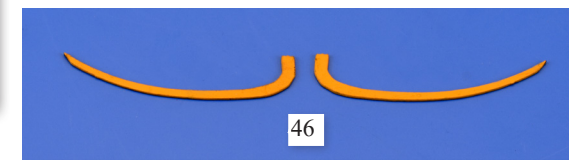

Above - Paint the bow main rails (46) yellow ochre all over

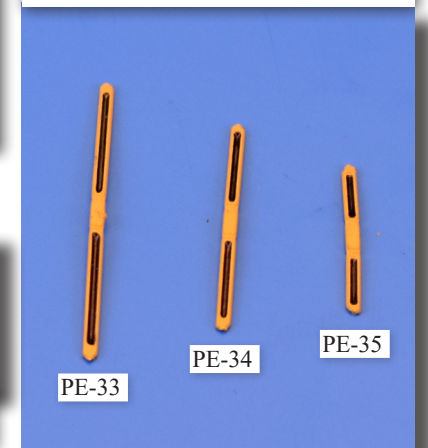

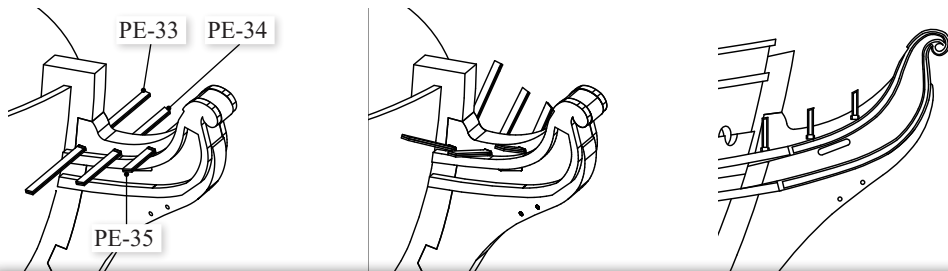

Above - Push the vertical bow frames through the slots located in the prow and bend each side upwards  
 Below - Pin the bow rails in place and then bend the three vertical rails down until the ends make contact with the inner edge of the part 46. The end of part 46 that touched the bow capping should have the top edge flush with the bow capping.

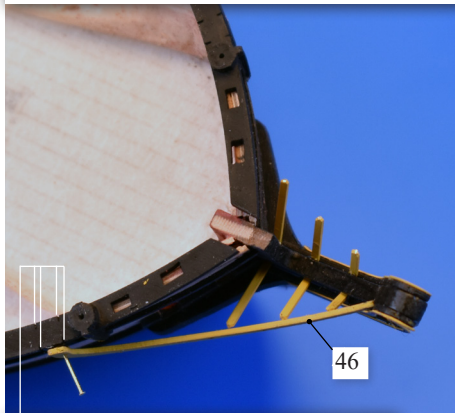

End of bow rail should match up with the 4 slots located in the capping rail. These are for the cathead positions, which the end of the bow rail sits directly under.



Once everything touches and is in place, apply a drop of glue to the ends of the vertical bow rails to fix them in place with part 46.

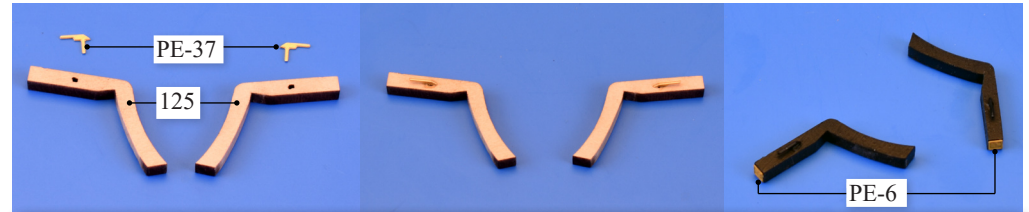
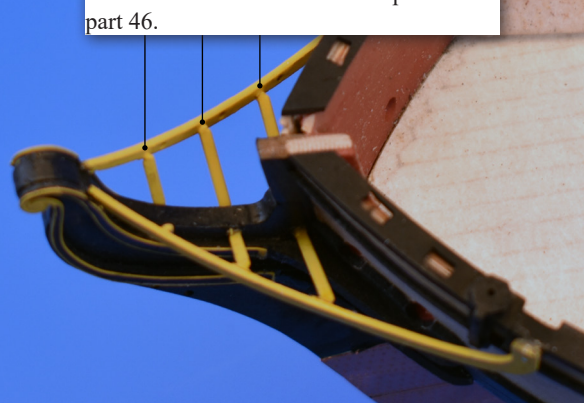

Above - Remove the catheads (125) and the cathead cleats (PE-37) and glue the cleat into the hole in the cathead side. Make sure the catheads and cleats are handed before gluing. Paint the catheads black and then paint the cathead end decoration (PE-6) yellow ochre and glue to the outer end of the cathead.  
 Below - Dry fit the catheads and modify if required. The area on the capping rail where the cathead sits over may need slight filing down in order for the cathead to sit correctly. Also, the bottom of the catheads may require filing down slightly for then to sit flush on the deck.

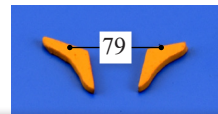
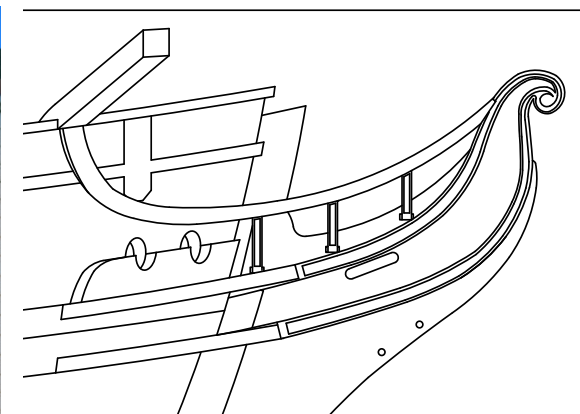

Once the catheads are securely fixed in place, paint the cathead knees (79) and glue in place so that the upper edge sits under the cathead and vertical contact edge sits flush with the bow rail. Since the prototype model was made, parts 78 have been modified so the lower part that fits to the bow rail is not so long.



### 27 - Bow timber heads

Remove parts 81 and 122 from their laser sheets and slot and glue parts 81 into their respective positions in the bow capping rail. Glue the bowsprit timber heads (122) to the top of the capping rail so they are just over 6mm apart, enough of a gap for the bowsprit to fit in between. These timber heads can be pinned as well as glued into position to ensure they are not inadvertently knocked off. Finally, paint the timber heads black. Deck masking tape can be removed at this time.

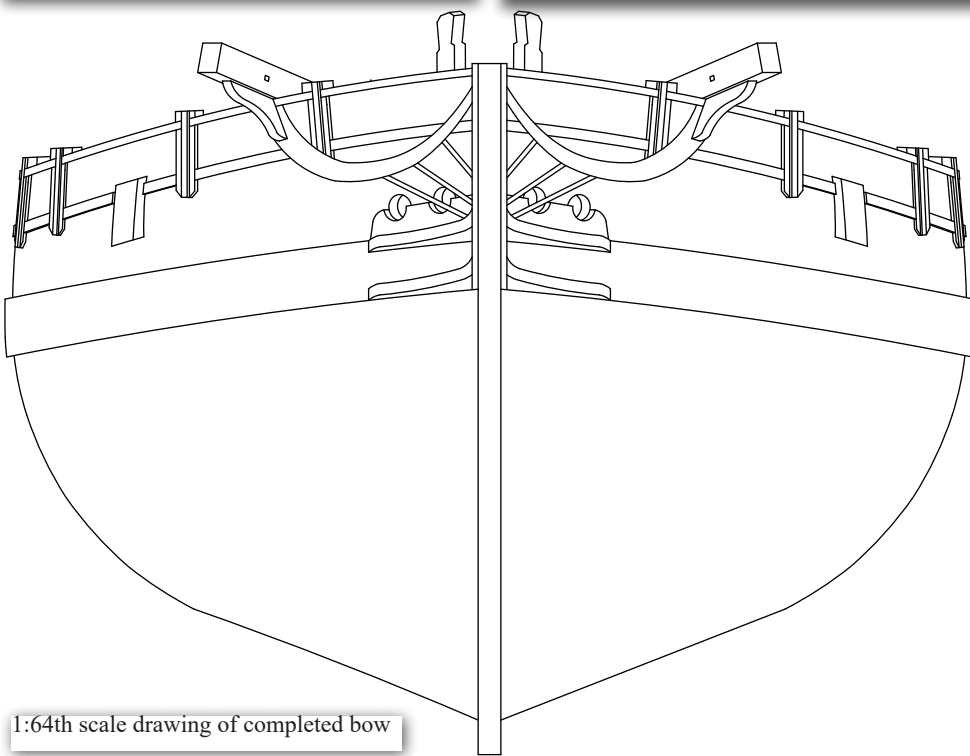
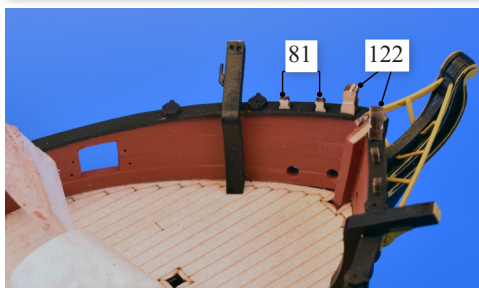
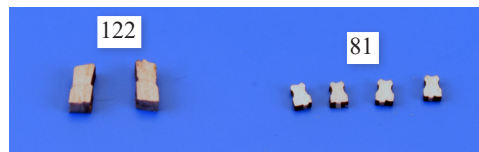

1:64th scale drawing of completed bow

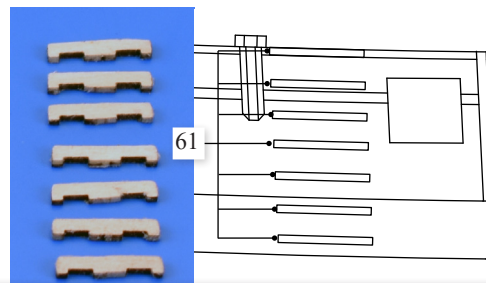

27 - Hull side steps (61). remove parts 61 from their host 1mm wood sheet.

Mark out the positions using the full size drawing above and glue each step into place. To ensure vertical alignment apply a length of masking tape down the hull and glue each step so the end touched the edge of the tape. Paint the steps on the main wale black, and the step located on the edge of the capping rail.

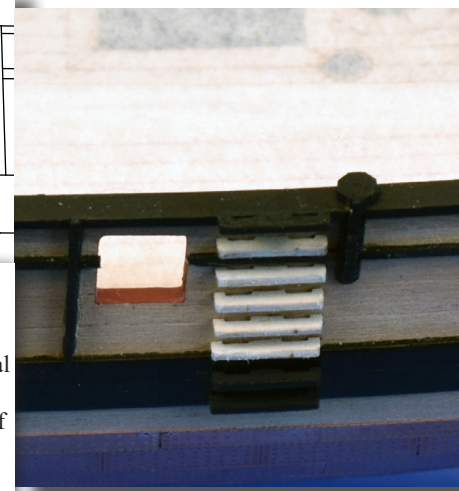

### 28 - Deck hatches and deck fittings

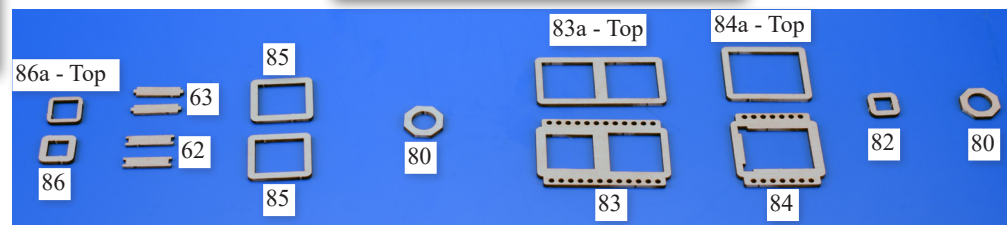

Glue the hatch and skylight combings together so there is a lip inside the openings which support the gratings

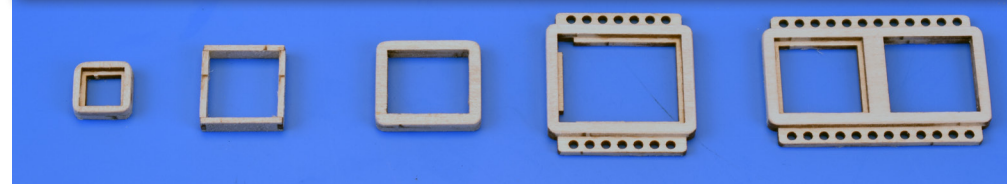

Optional - The combings can be painted red and the mast bases and stove flue base can be painted black.

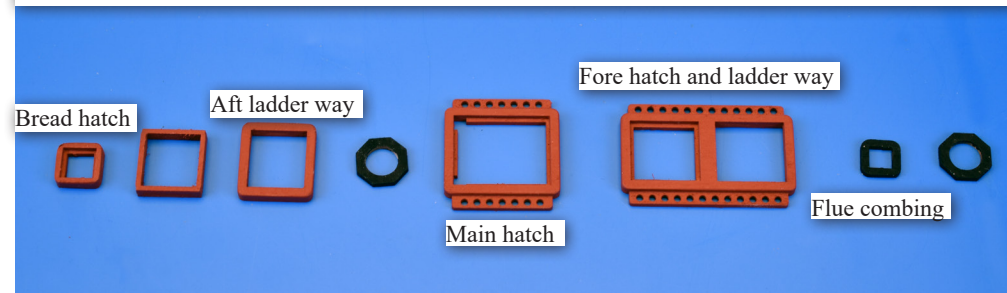

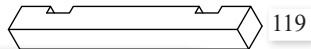
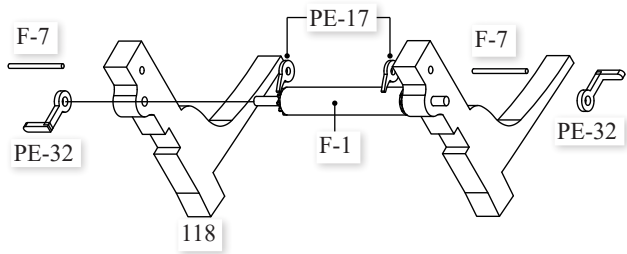

Main mast aft bitts assembly

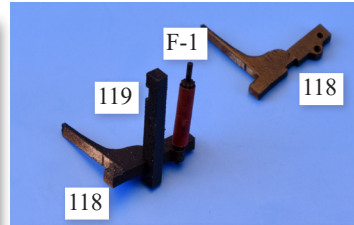

Insert the drum (F-1) into the hole located in 118. Glue the crossbeam (119) into its slot and then glue both sides (118) together. Paint the drum a wood colour and all other wood fittings black.

Drum gear turning handle  
Bend at fold line

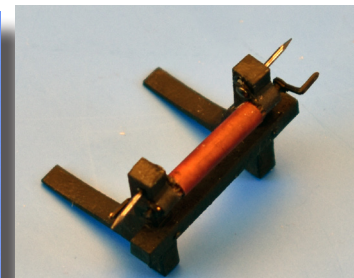
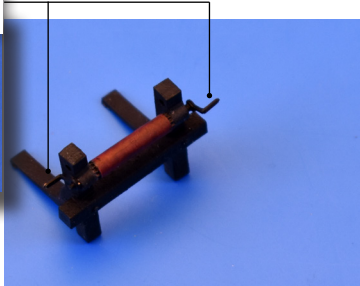

PE-17 F-7

Fix PE-17, the drum windlass pawls into position using brass pins. When glued in place, trim off the excess ends of the pins as shown below.

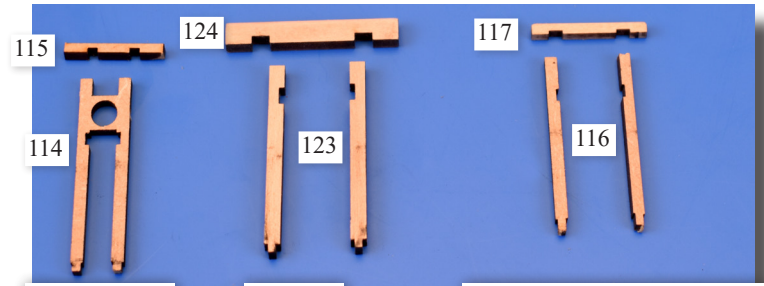
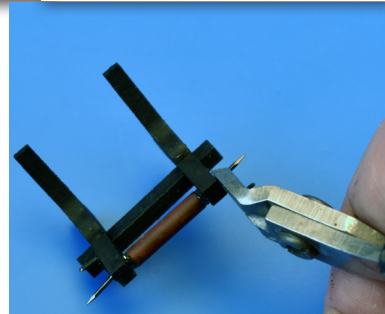
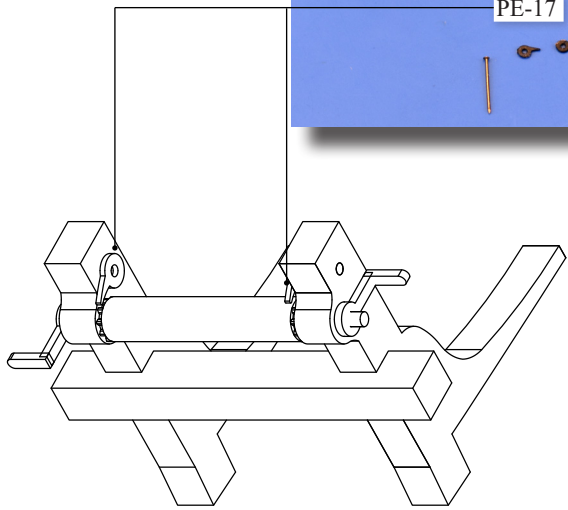

Bowsprit bitts Fore bitts Main bitts (Front of main mast)

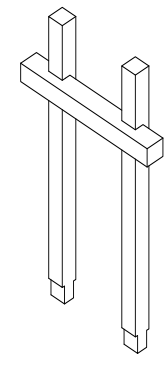
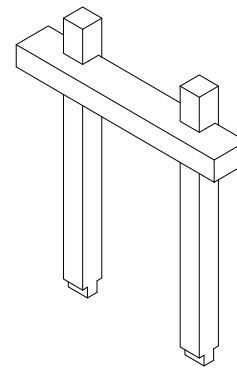
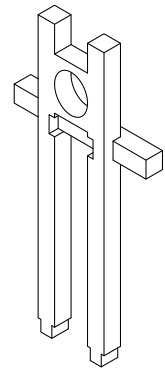

Deck pump

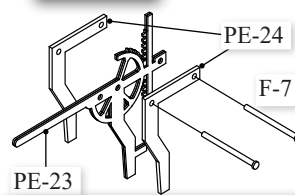

Above - Align the 3 parts using pins and then glue



Remove the excess pin

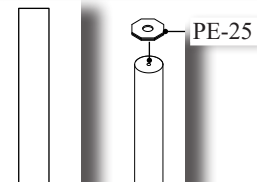

4mm diameter dowel x 40mm long (x2)

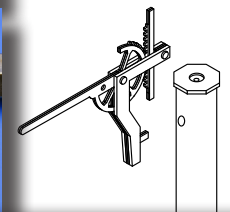
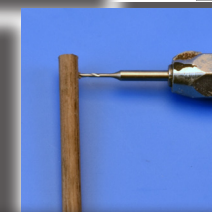

Above - Mark out where the fixing pin meets the dowel and drill a 0.8mm hole at this position and glue the pump head assembly in place. Paint the head assembly black.



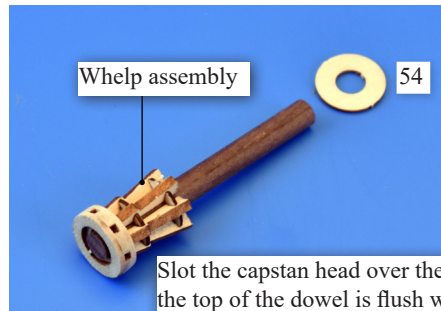
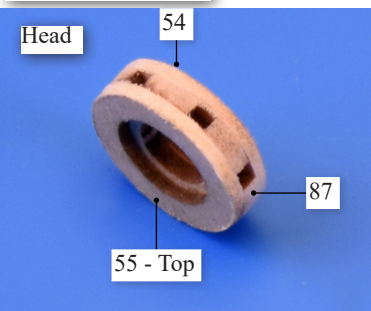
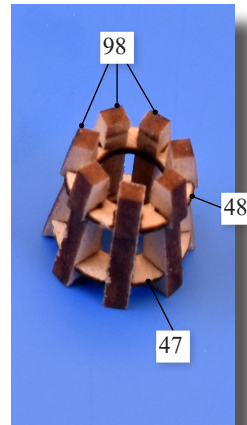
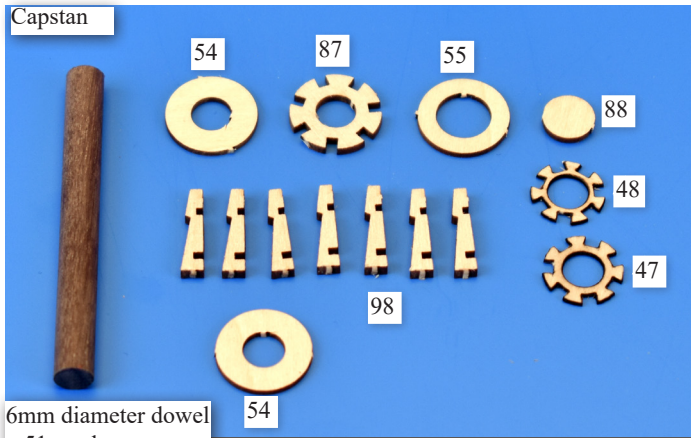

Slot the capstan head over the dowel so the top of the dowel is flush with the top of part 87. Slot and glue the capstan whelp assembly in place and then the base (54)

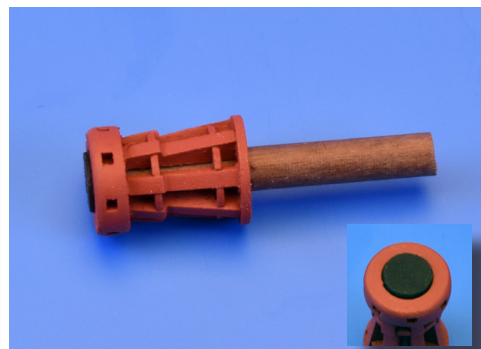
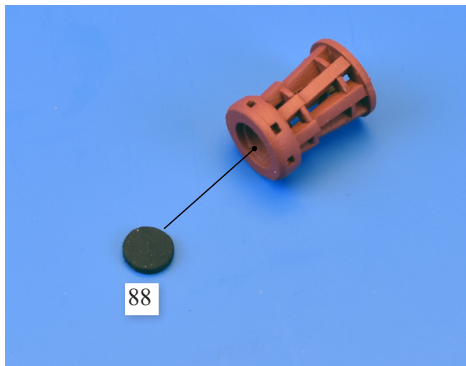

The completed capstan head and whelp assemblies can be painted red. To highlight the top, part 88 can be painted black and then glued into place

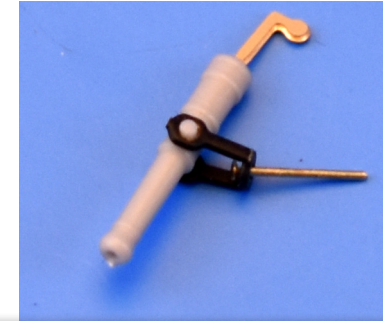
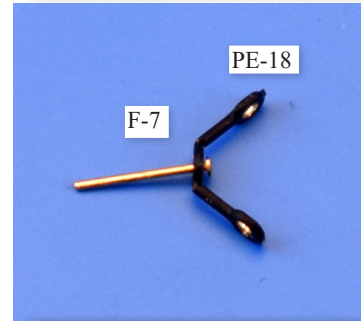
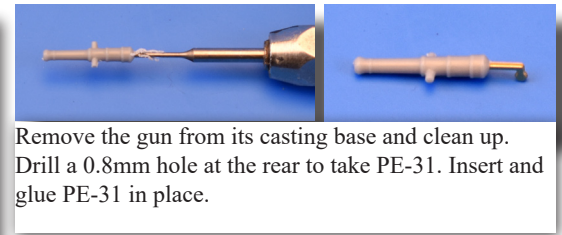
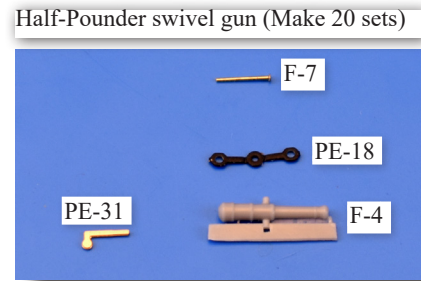

Fold the two ends of the swivel gun bracket (PE-18) and drop in a brass pin (F-7) through the hole in the middle of the bracket. Insert the cannon and fold the bracket through the barrel trunnion to secure the assembly. When all 20 are complete, paint them black.

Please note - The real Speedy was assigned with only 12 swivel guns, as they would have been moved from one post to another where required. It is doubtful if all 20 posts were permanently populated.



4-pounder cannon (Make 14 sets)

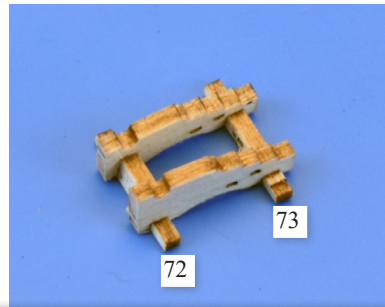
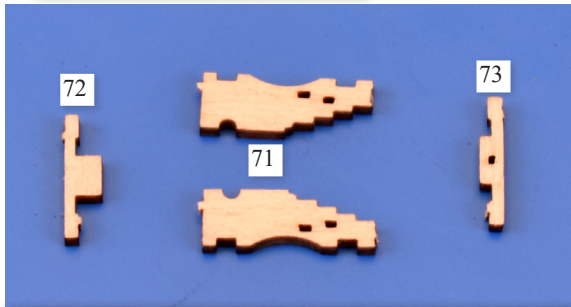

Glue the four parts that make the base gun carriage using PVS wood glue. Note that the rear axle (73) has a slot for an eyebolt, and is wider as the carriage tapers outwards toward the rear.

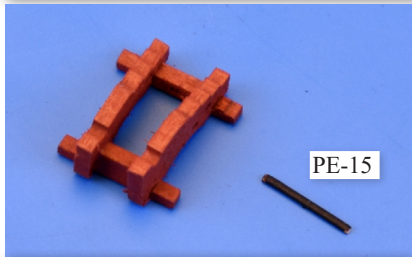

Paint the carriages red (if painted) and paint the bolt (PE-15) black and insert and glue through the holes (forward) in the carriage sides

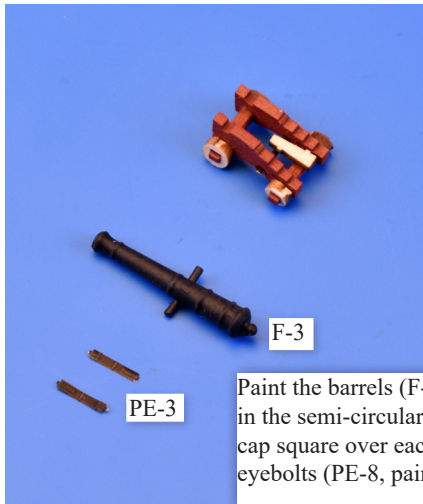
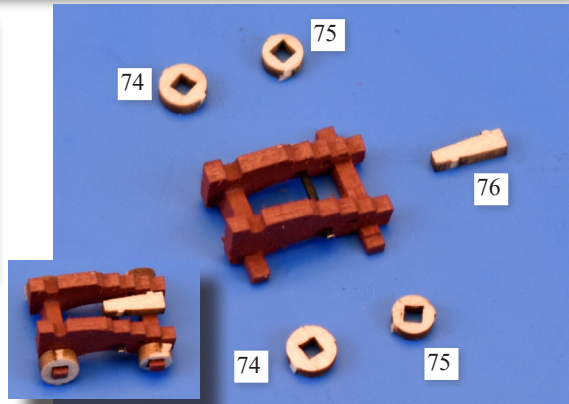

Paint the barrels (F-3) and the cap squares (PE-3) black. Glue the barrel in place in the semi-circular notch on the top edge of the carriage sides and then glue the cap square over each cannon trunnion. To complete the assembly, add the three eyebolts (PE-8, paint black) into the three slots in the carriage sides.

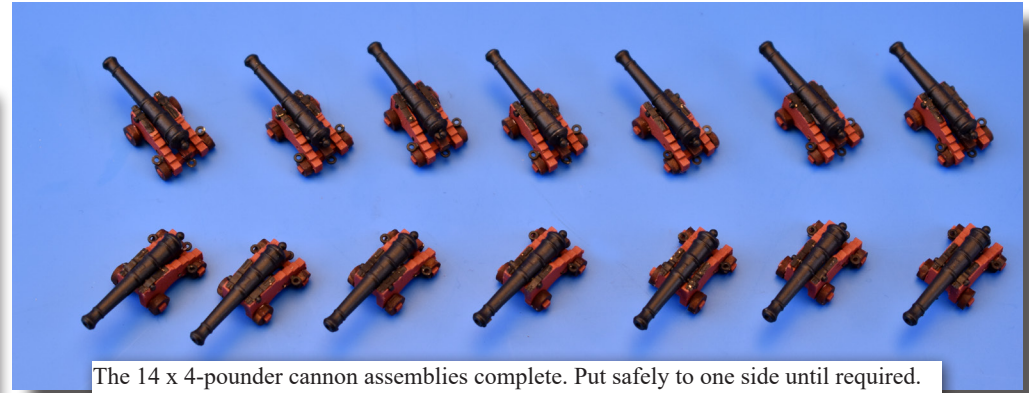
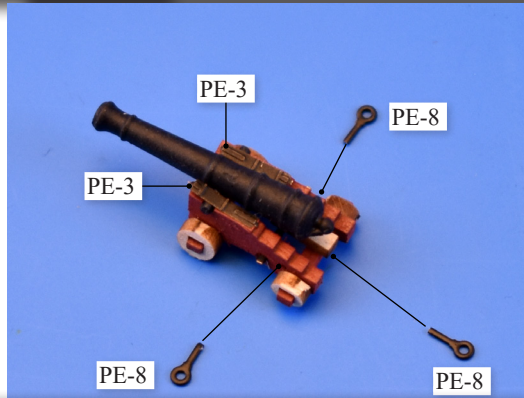

The 14 x 4-pounder cannon assemblies complete. Put safely to one side until required.

General views of a typical cannon breech rope and training tackle

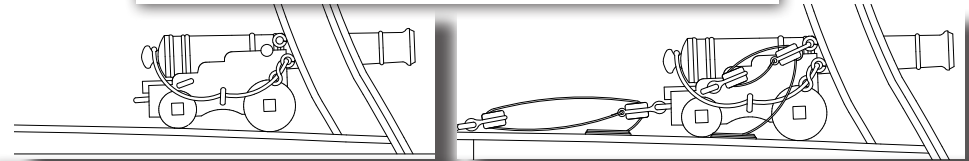

Optional - Above left - Rigging the cannon with breech rope only.

Above right - Rigging the cannon with breech rope and training tackle. The blocks are all 2mm single blocks (Not included in kit), and the rope would be 0.1mm, with the breech rope being 0.75 natural.

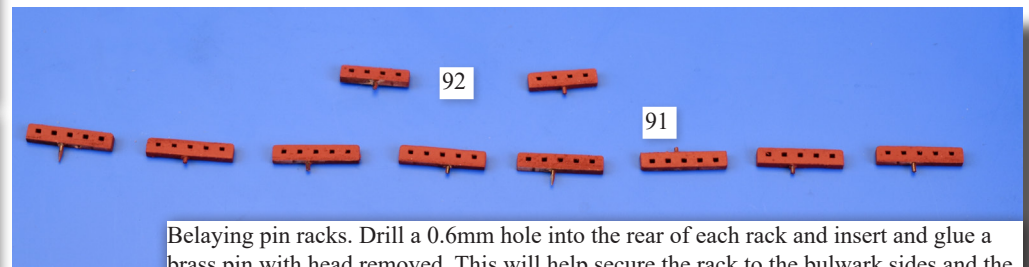

Belaying pin racks. Drill a 0.6mm hole into the rear of each rack and insert and glue a brass pin with head removed. This will help secure the rack to the bulwark sides and the tension of the rigging lines. Paint all belaying pins (PE-29) a wood colour or black.



Left - Inner bulwark and deck ring bolts for cannon tackle. Paint black and add the ring (PE-7a) to the eyebolt (PE-7) and glue in place in the holes located at the edges of each gun port opening on the inner bulwarks. Use the full size drawing on the main plans for correct placement.

Inner bulwark detail

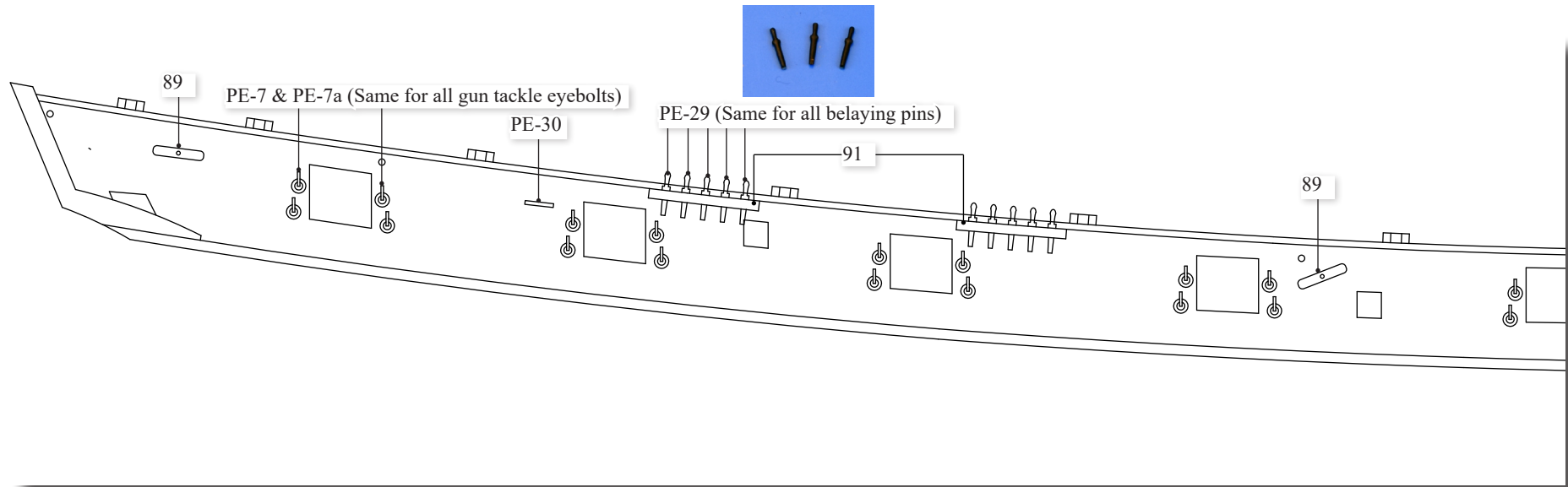

Bulwark cleats. Paint the photo etched cleat (PE-30) and larger laser cut cleat (89) black. Insert a pin through the middle of part 89 to help secure it in place.

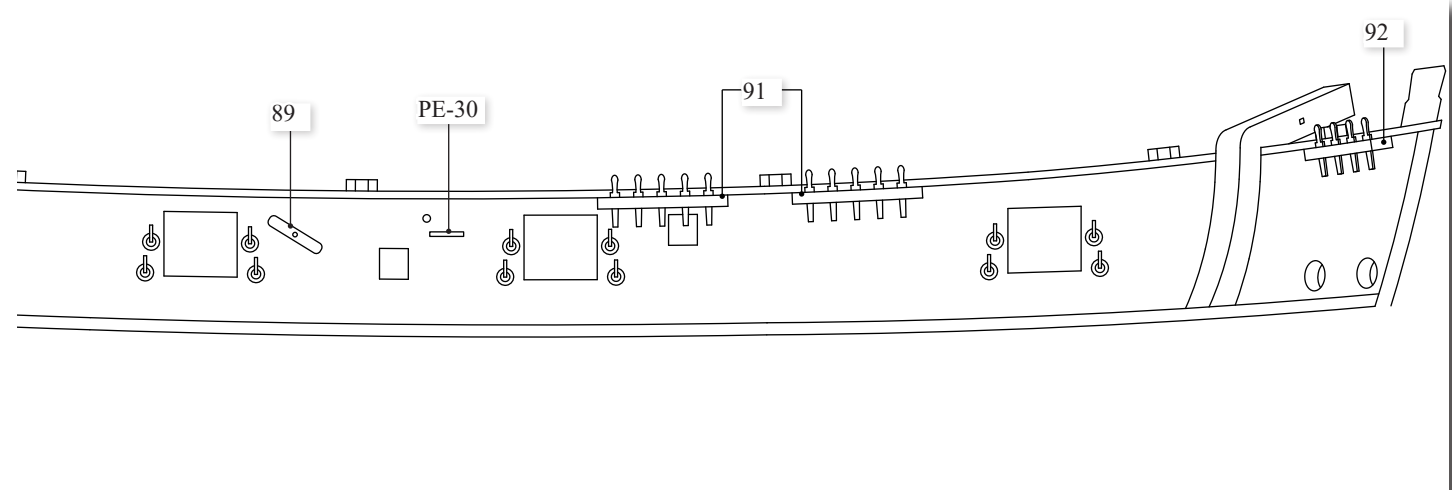

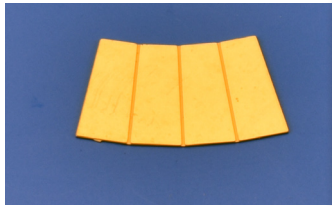

Stove flue (PE-19)  
 Bend the four sides at the bend lines and then glue where both ends meet. Paint the flue black. This method will give the flue a more realistic appearance.

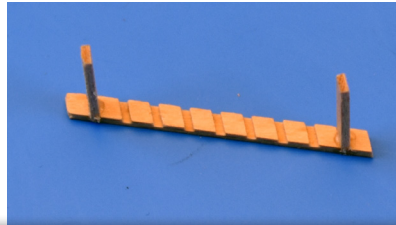
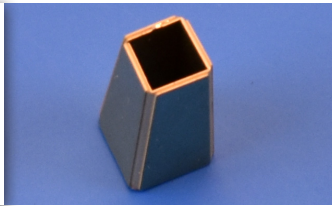

Ladder assembly (F-8). There are two ladders to make up, one for the fore hatch and one for the aft hatch. Cut the ladder sides in half, which will give the correct length of the ladders from lower deck to top deck hatch. Cut the forward ladder steps to a length of 14mm and the aft ladder steps 13mm. You can double check the sizes by measuring the hatch openings and taking off approximately 2.5mm. Glue the first and last step into the slots first and then glue the two ladder sides together. Slot and glue the remaining steps into position. When complete, the face of the ladder sides can be planed using 1x3mm wood strip, sanded to the width of the ladder side.

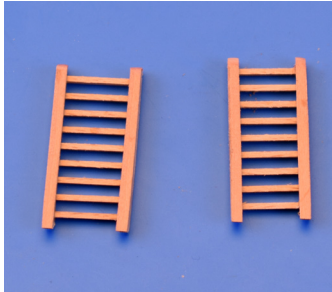
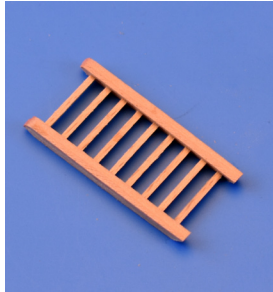
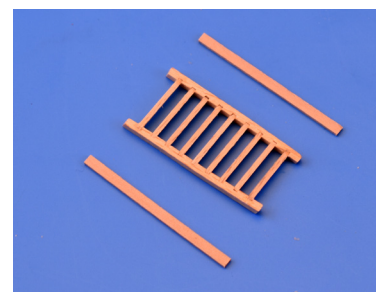
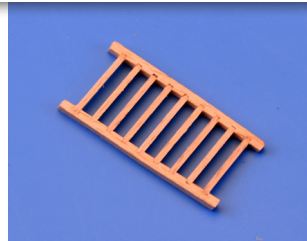
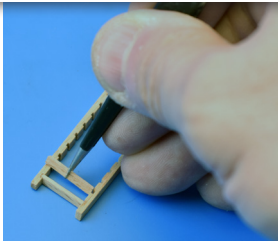
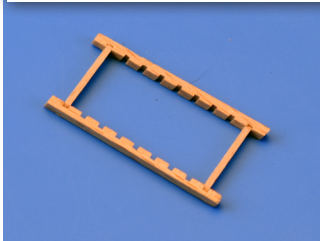

## 29- Channels and chain plates

Remove the channels from their 1.5mm sheet and add a small pin with head removed to the hull contact edges. These will help secure the channels firmly in place. Paint the channels black (or varnish) and mark out onto the hull the positions and fix in place using the full size drawings for correct placement.

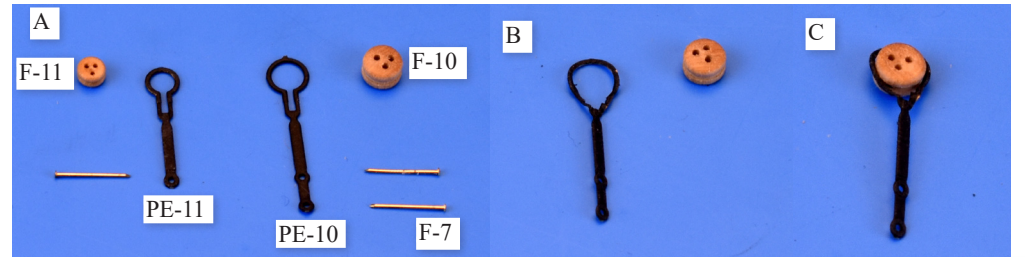
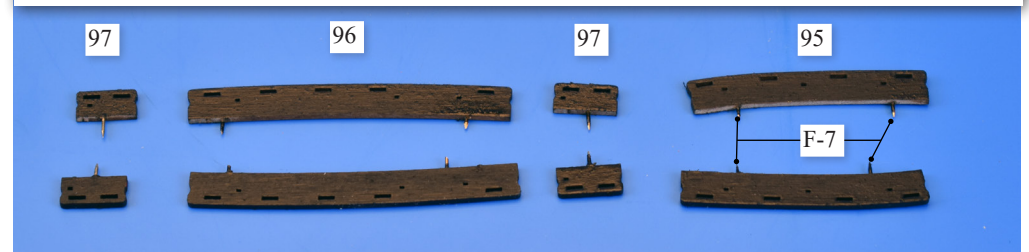

Deadeye and chain plate assembly. Paint the chain plates black and then open up the loop that will hold the 5mm or 3mm deadeye (B). Push the deadeye into the loop (C) and then close the loop back up to secure the deadeye. Once the 18 sets of 5mm and 8 sets of 3mm are done, fix them in place through the slots in the channels and pin the ends into the hull sides, as shown below. 5mm deadeyes and chainplates fit into the fore and main channels (95 & 96) and the 3mm into the fore and main stools (97). Drill and pin the lower chainplates to the hull/main wale.

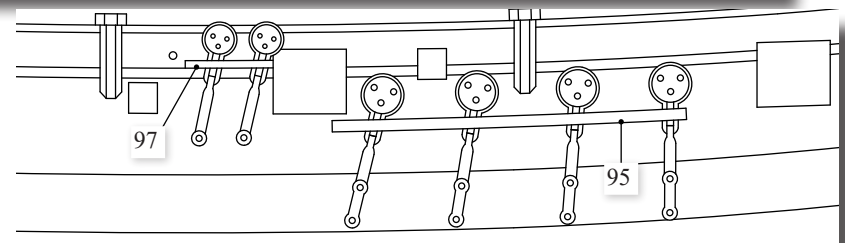
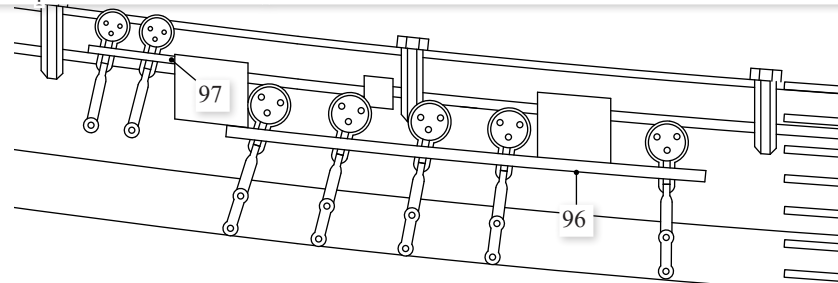

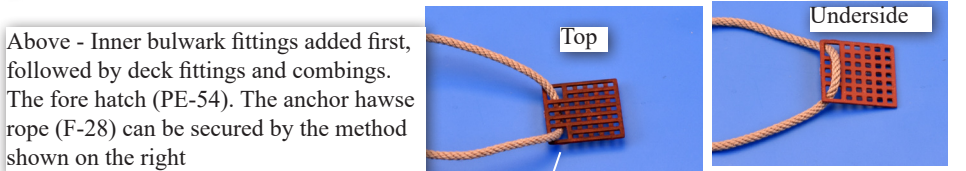
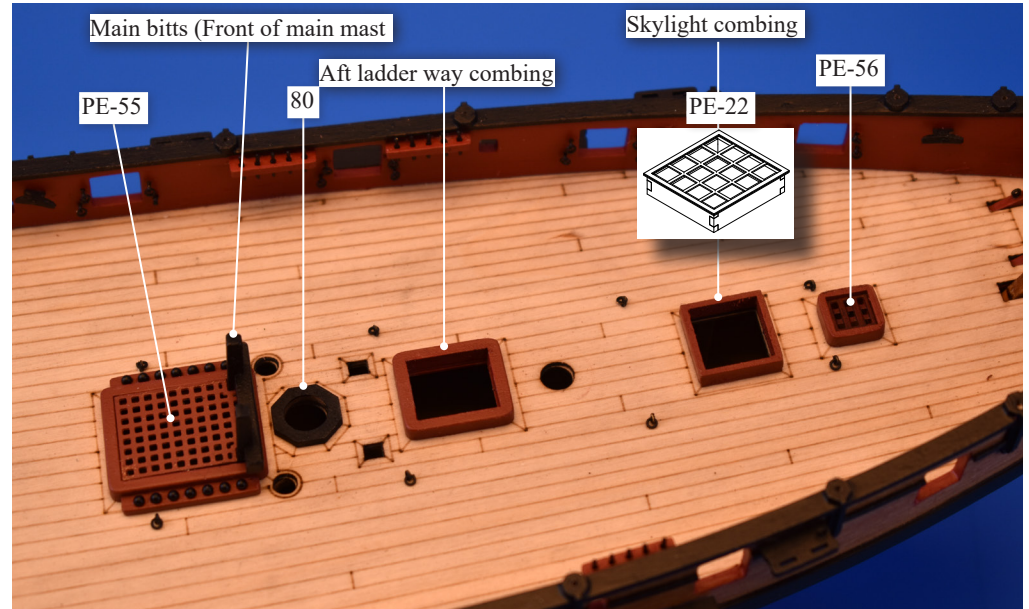
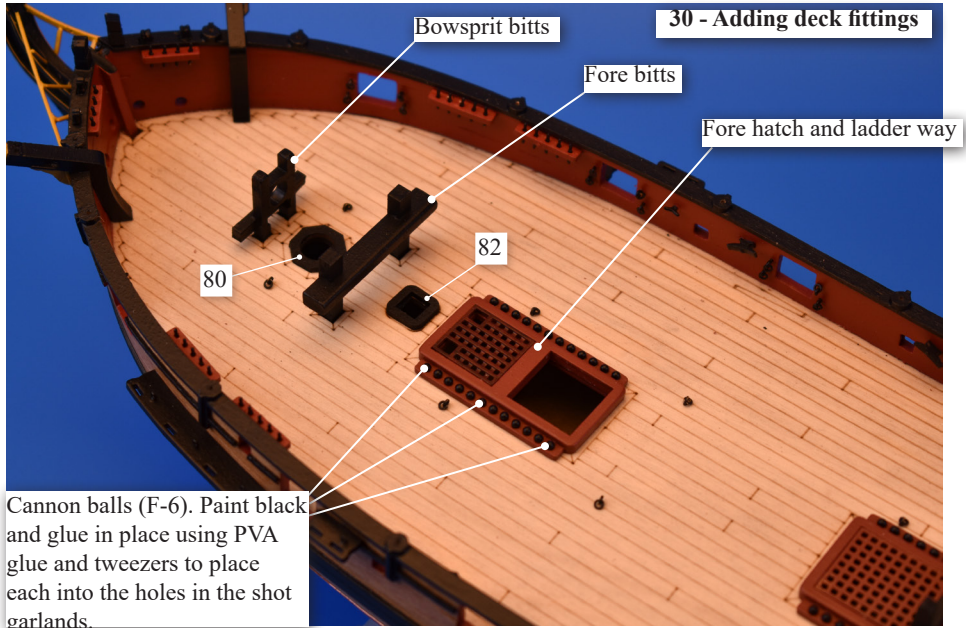

Above - Inner bulwark fittings added first, followed by deck fittings and combings. The fore hatch (PE-54). The anchor hawse rope (F-28) can be secured by the method shown on the right

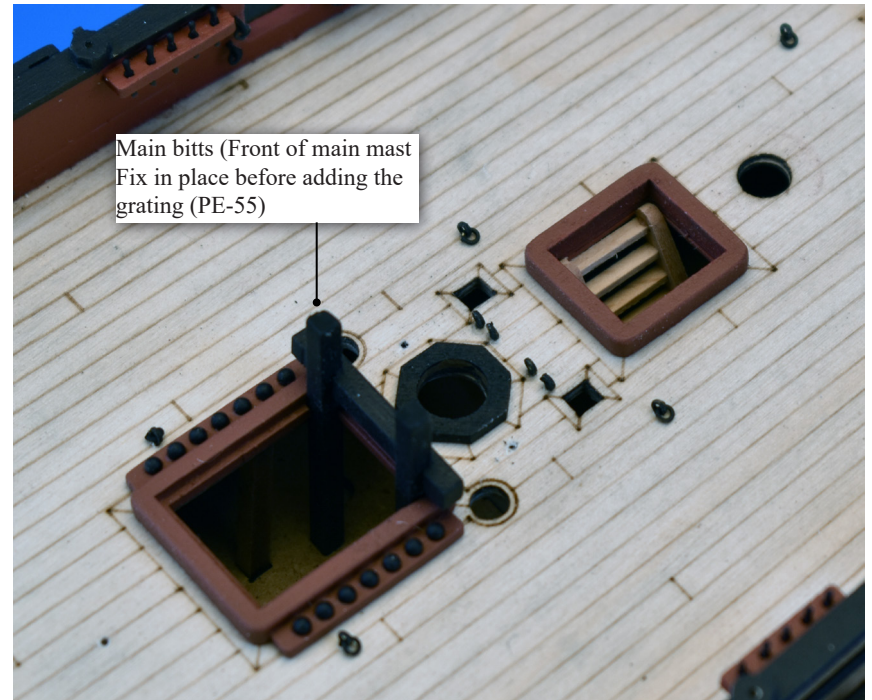
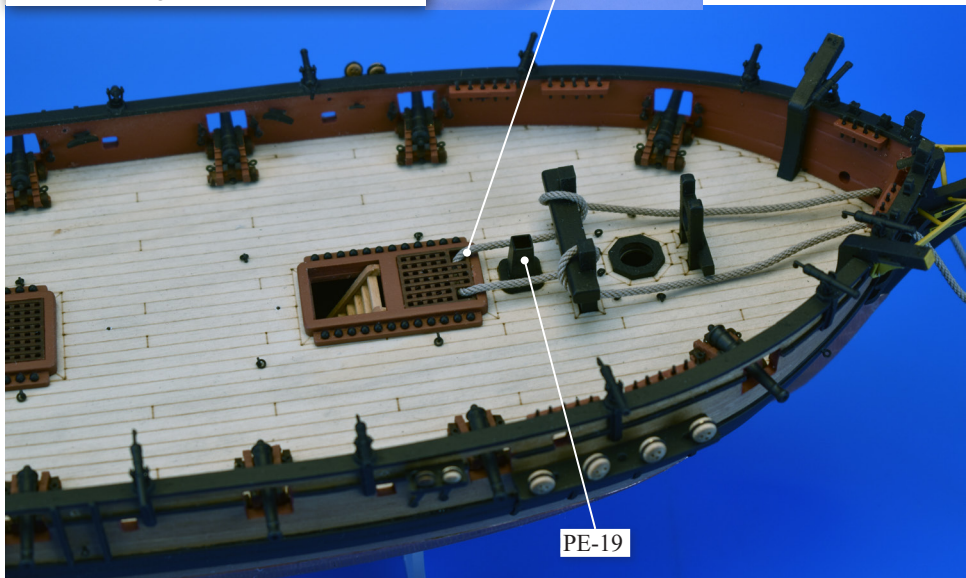

Deck fittings and hatch combings general arrangement

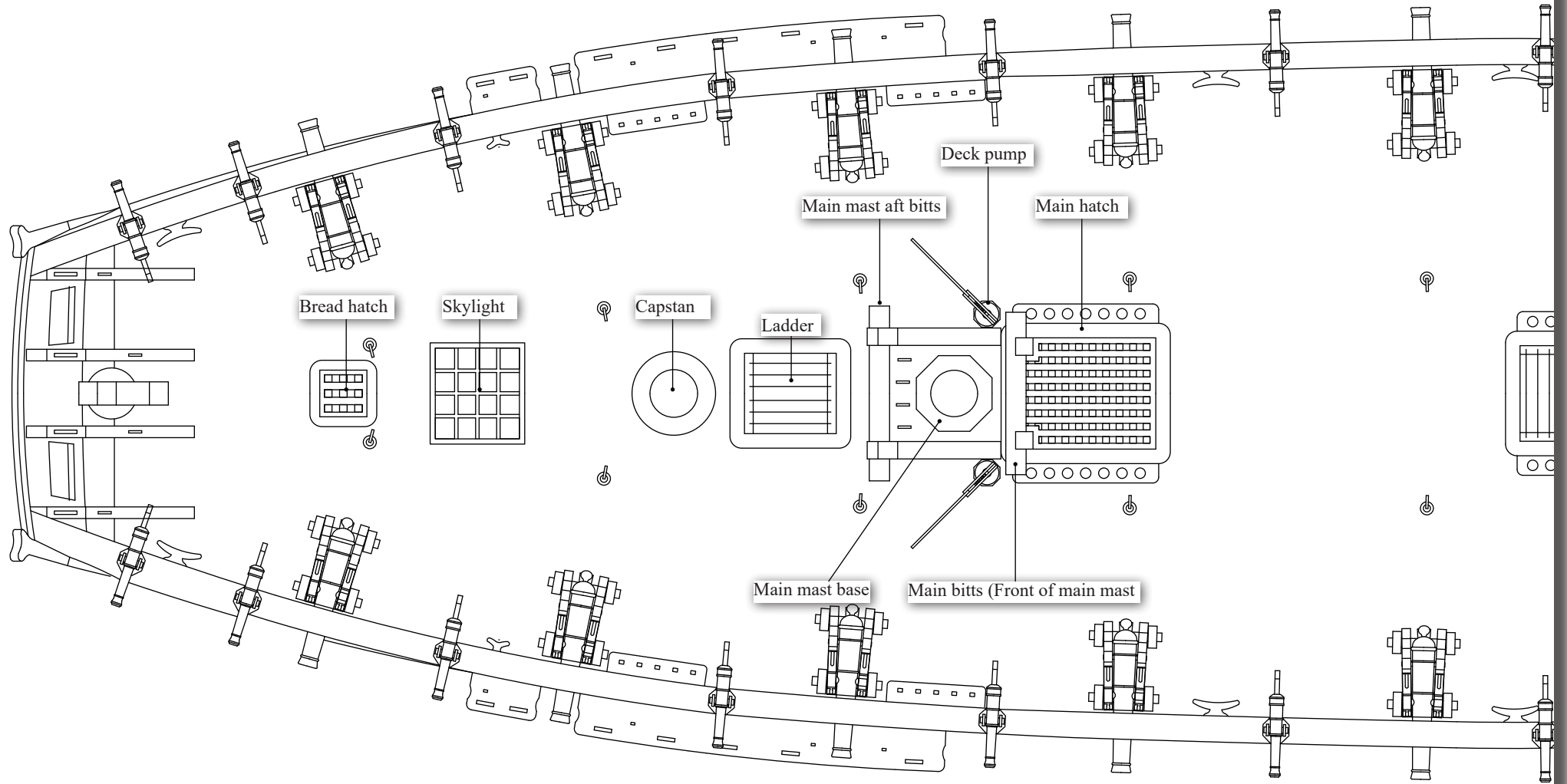

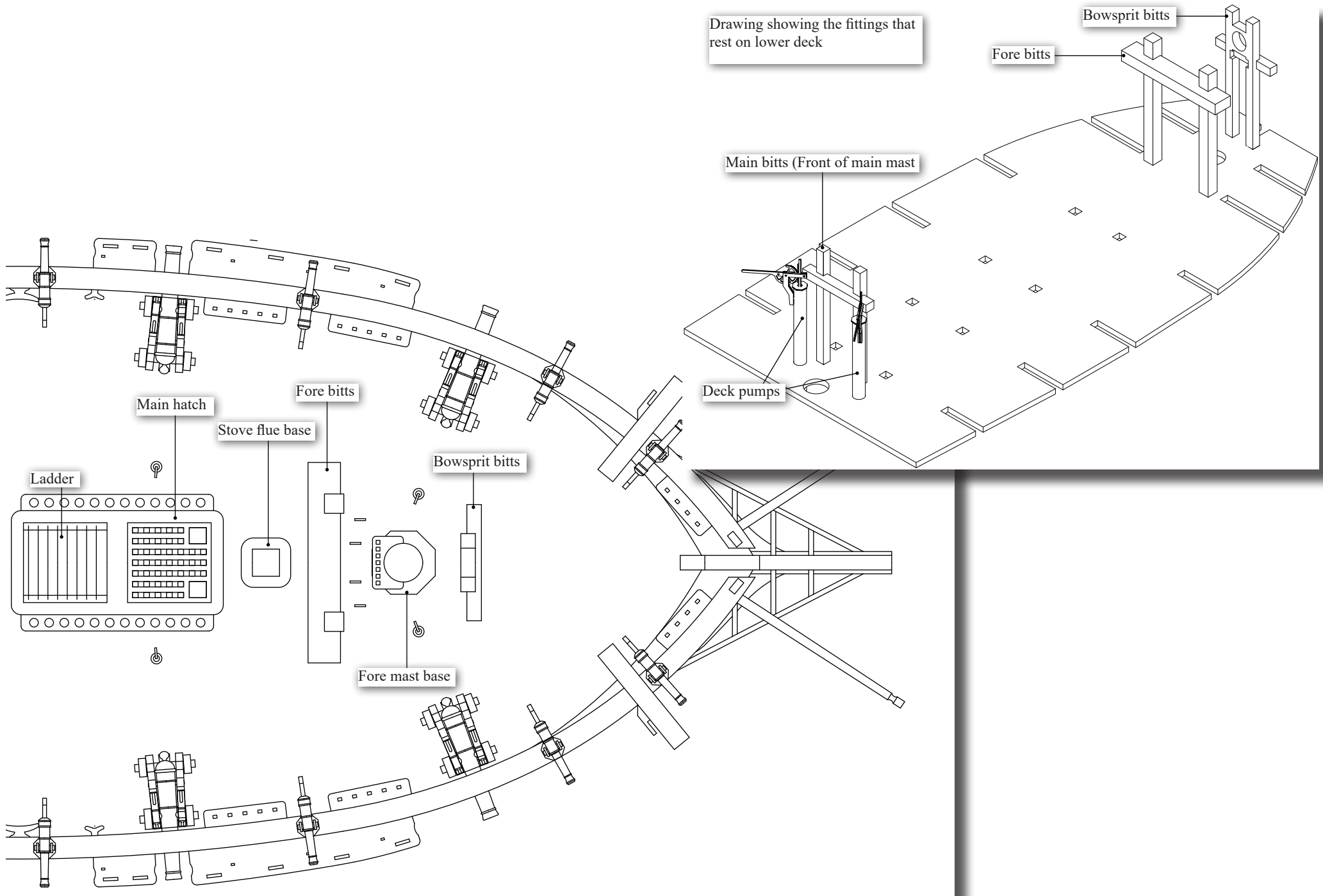

### 31- Cutter Assembly

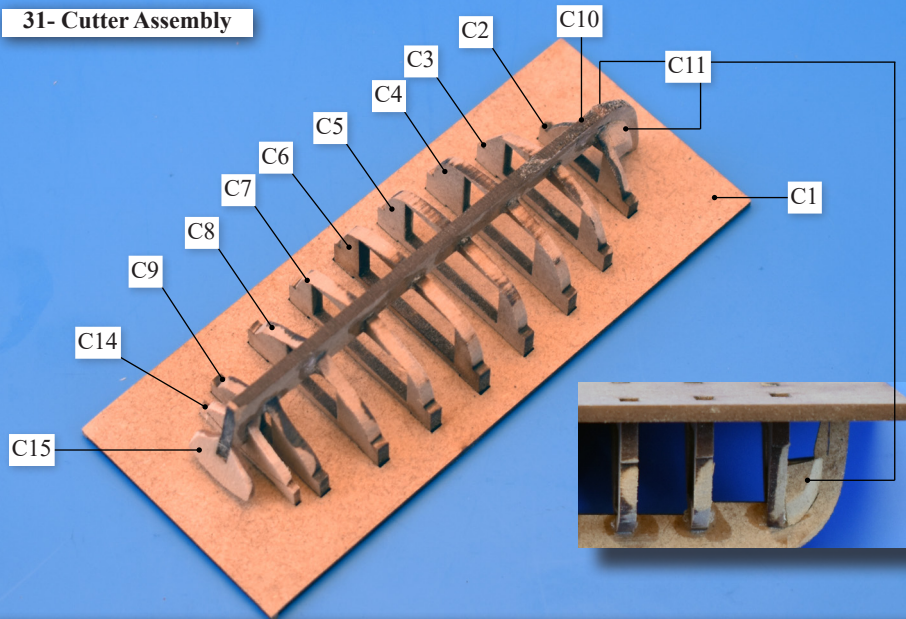

Slot the bulkheads (C2-9 and C14) into the base (C1) and then slot and glue the keel (C10) in place, along with the stern board (C15). Bevel the edges of parts C11 to follow the run of the front planking and then slot and glue into position to the front frame and keel.

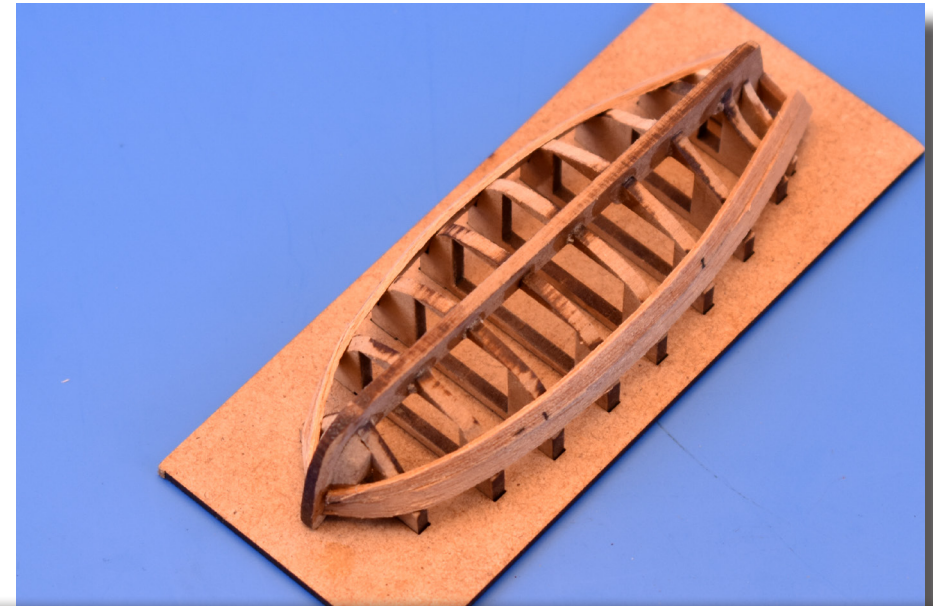

Plank the cutter in the same way as you planked the ship hull, but using 1x3mm wood strip. Cyano or similar adhesive is recommended to fix the planks in place. Start planking at the top edge of the bulkheads and work your way down. The front and rear of each plank will need to be tapered, just as the full size hull planking.



Once the bulkheads have been securely glued to the keel, it should be ready for planking. Carefully sand the bulkheads as you would for the main ship's hull, so that the run of the planking has maximum contact with each frame, or as much contact as is possible. Use 1x3mm planking strips.

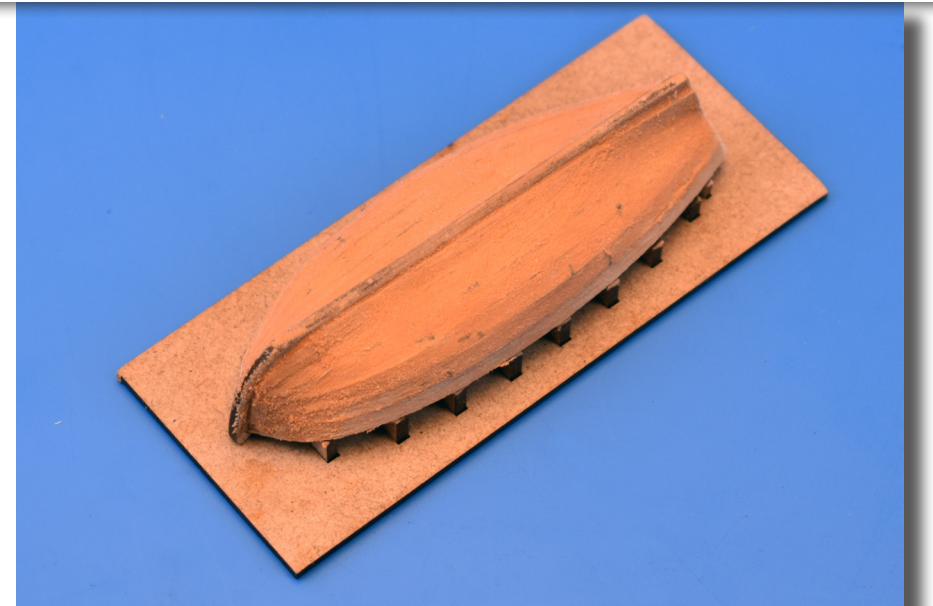



Hull sanded smooth and a waterline marked onto the hull, as the lower part is to be painted white. Although all of hull can be painted or just varnished if desired.

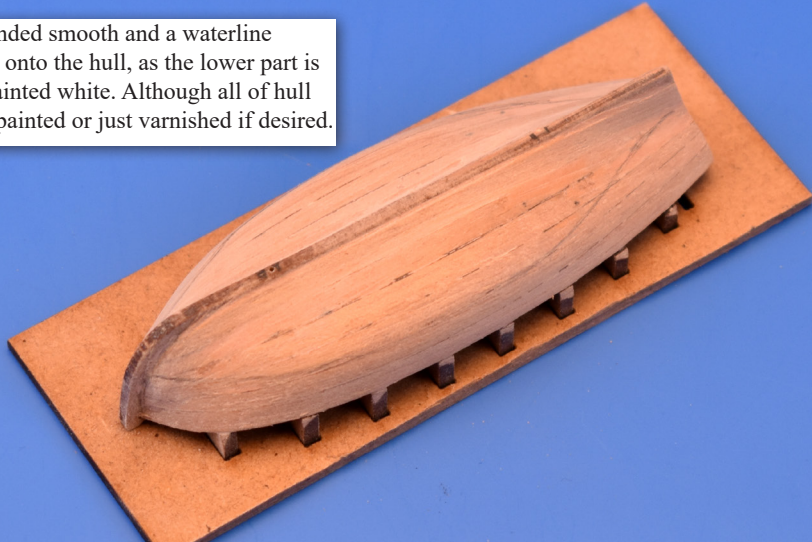

Left - Once fully planked and the outer hull is complete, the assembly can be removed from its building base.



Below - Remove all frames down to the floor level and sand and fill the inner boat hull smooth.



CPE-4

CPE-3

CPE-1

CPE-2

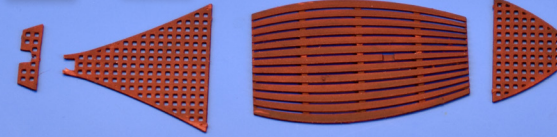

Remove the four parts that make up the floor of the cutter from the 0.4mm photo etched sheet and paint wood colour. I used a red oxide spray paint followed by Vallejo wood grain paint for the above effect.

CPE-1



CPE-2



Glue the floors in the order shown - CPE-1 first, followed by CPE-2, CPE-3 and then CPE-4.

CPE-3



CPE-4



Once the floors are in place, the rear seat can be added (C16). bevel the contact edges of the seat so that it fits flush with the boat inner sides.

C16



Optional - Ribs.

You can simulate the inner ribs by cutting 1x3mm strip in half to make them 1.5mm wide. Bend and glue in place as per the drawing shown on the right. Add a length of 1x1.5mm strip longitudinally about 2.5mm down from the top edge for the seats to sit at the correct level.

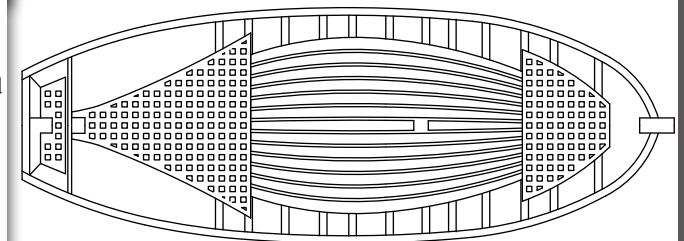

Left - Trim the excess ribs using a pair of side cutters so that they are level with the top of the hull side, as below.

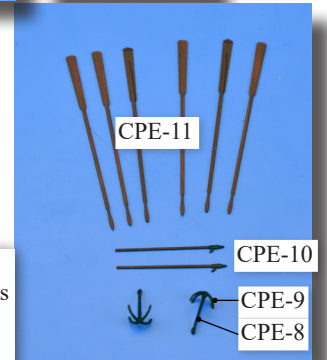
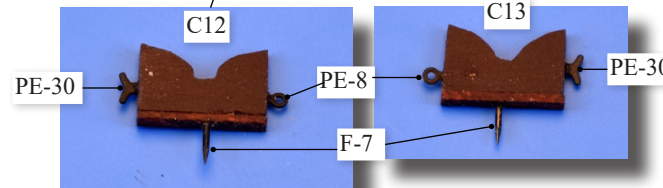
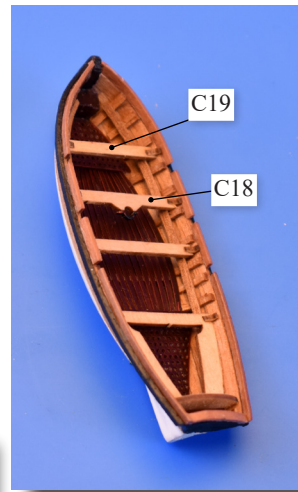
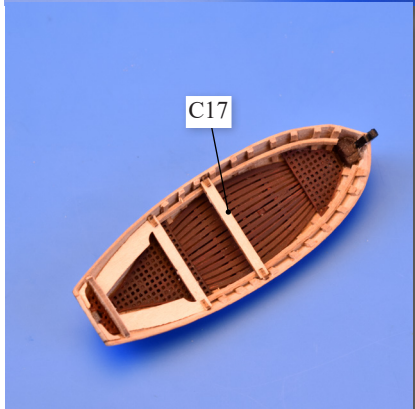
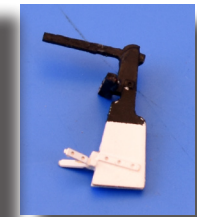
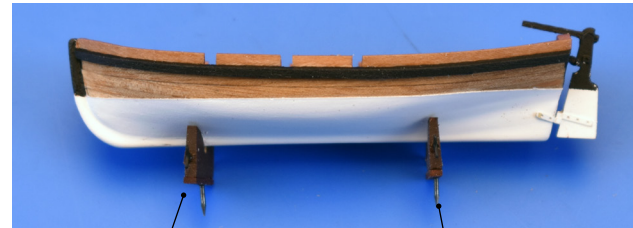
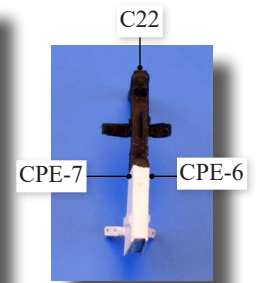
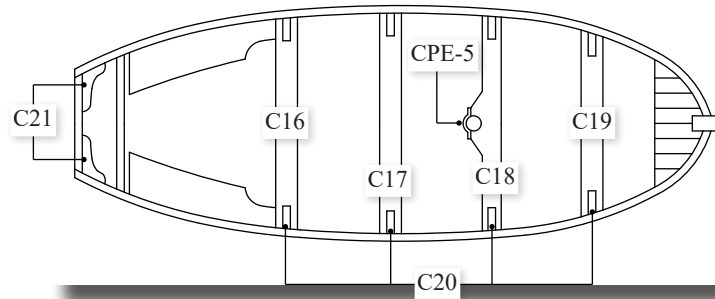

Add the gunwale by simply cutting 1x3mm wood strip to 1.5 in width and glue to the top edge of the hull sides, leaving 1mm gaps for the oars to sit. Add the rudder if desired, as well as the oars, pikes and small grapnel anchors. Add the chocks and place on deck.

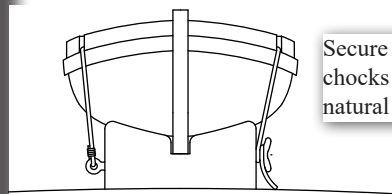
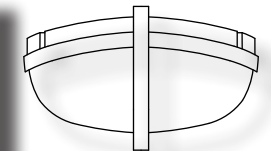
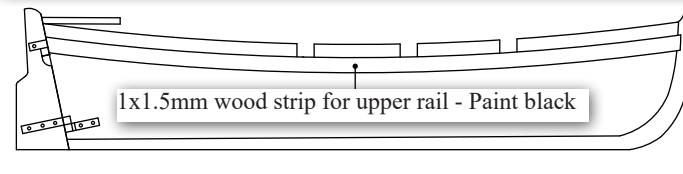
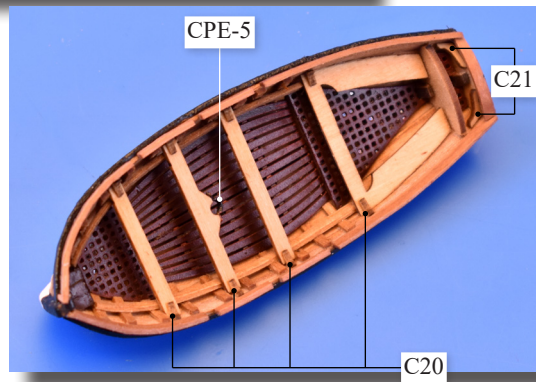

Secure the boat to the chocks using 0.5mm natural thread.

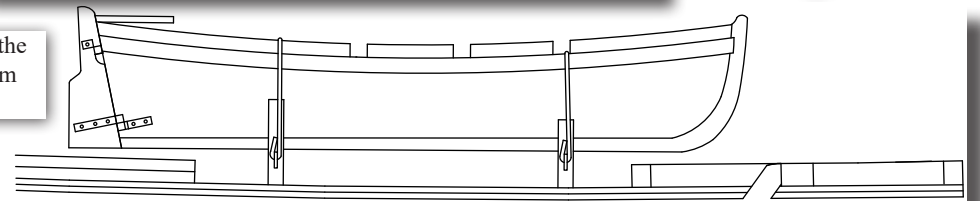

Deck

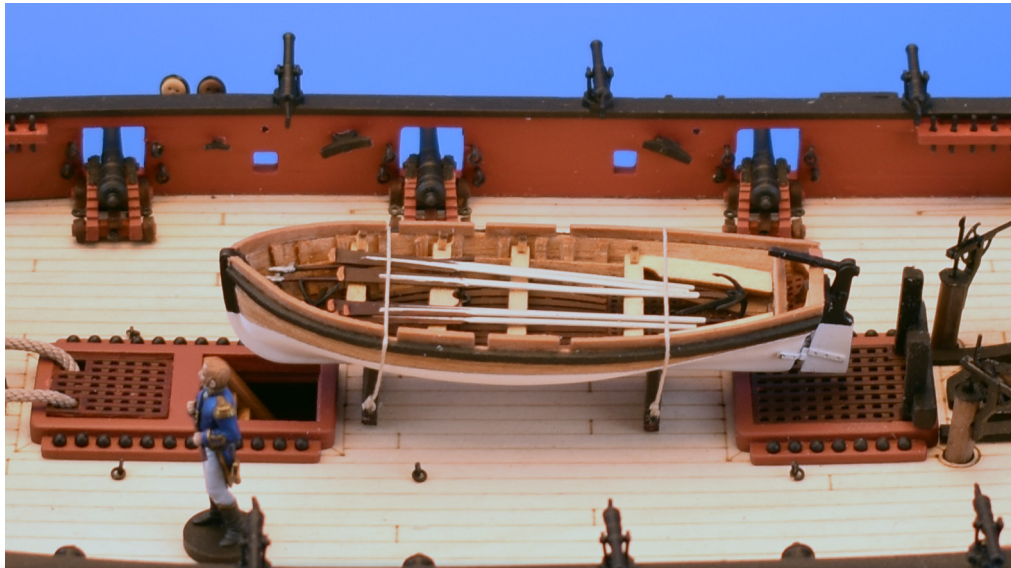

Cutter assembly in place. It is pinned in place, not glued. This is because the cutter was removed while rigging the model, to make it easier for belaying certain rigging lines. It was simply pinned back in place when rigging was complete.

Below - The completed hull assembly. The figure can be placed wherever you like. For a more scale appearance, carefully remove the base and use a small drop of glue to fix the figure where you like.



The 1:64th scale Cochrane figure paint scheme. Glue the sword to the position shown.

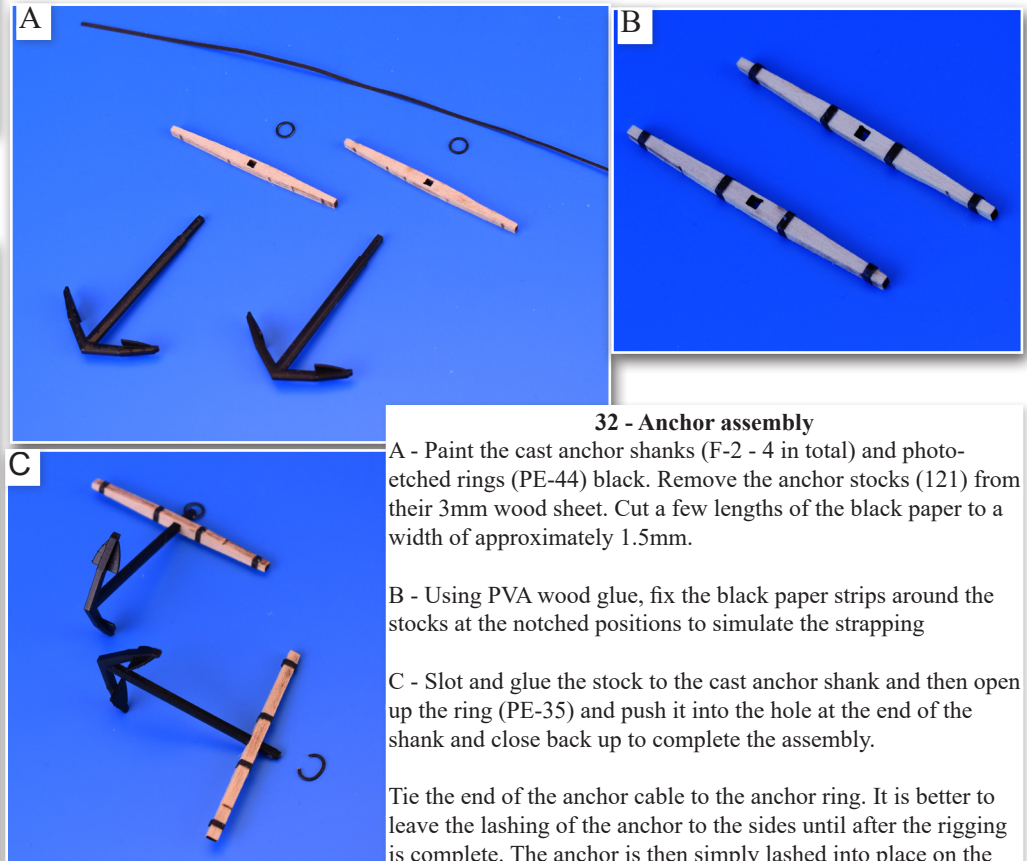

### 32 - Anchor assembly

A - Paint the cast anchor shanks (F-2 - 4 in total) and photo-etched rings (PE-44) black. Remove the anchor stocks (121) from their 3mm wood sheet. Cut a few lengths of the black paper to a width of approximately 1.5mm.

B - Using PVA wood glue, fix the black paper strips around the stocks at the notched positions to simulate the strapping

C - Slot and glue the stock to the cast anchor shank and then open up the ring (PE-35) and push it into the hole at the end of the shank and close back up to complete the assembly.

Tie the end of the anchor cable to the anchor ring. It is better to leave the lashing of the anchor to the sides until after the rigging is complete. The anchor is then simply lashed into place on the chain plates/lower deadeyes using 0.5mm natural thread.

### 33 - Masts, yards and rigging

Please note - The following is supplementary to the full size plans, and not a step-by-step building guide. Use the full size plans for all measurements and locations of parts and rigging.

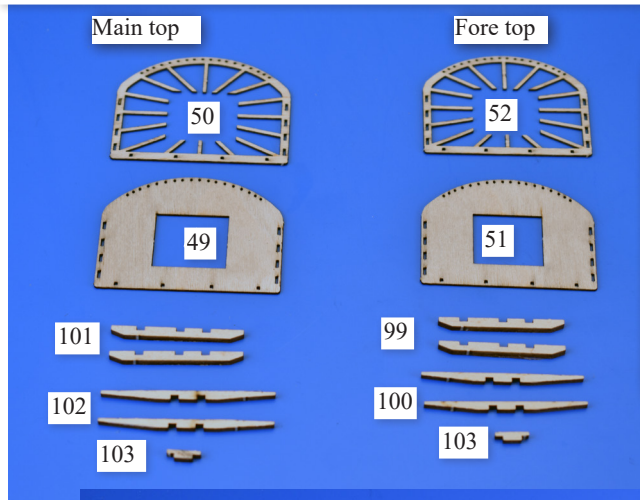

Parts 50 and 52 show the crows feet holes on the forward rim. These were taken off because during Cochrane's period of command, it is highly unlikely crows feet rigging was still in use. The holes were kept for parts 49 and 51 for those who may wish to model the Speedy at an earlier time in her career. Once the upper and lower tops have been glued together, drill out the holes.

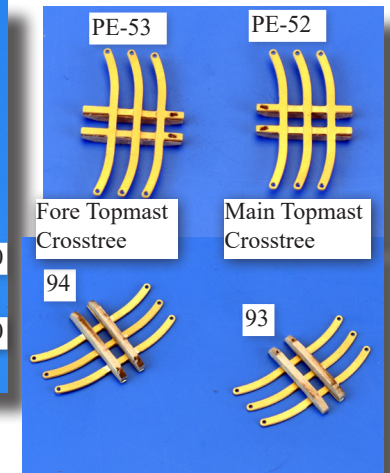
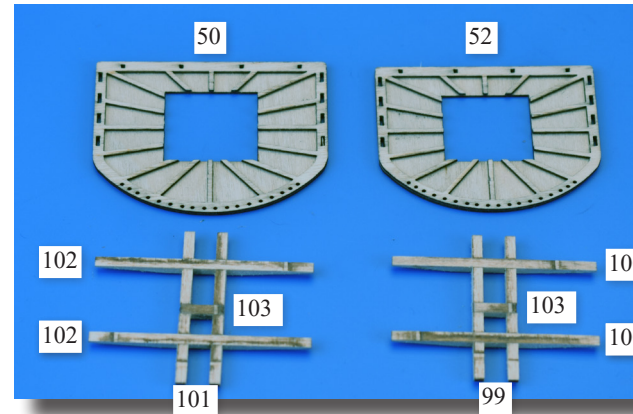

Mast and bowsprit sections shaped and ready to be fitted together.

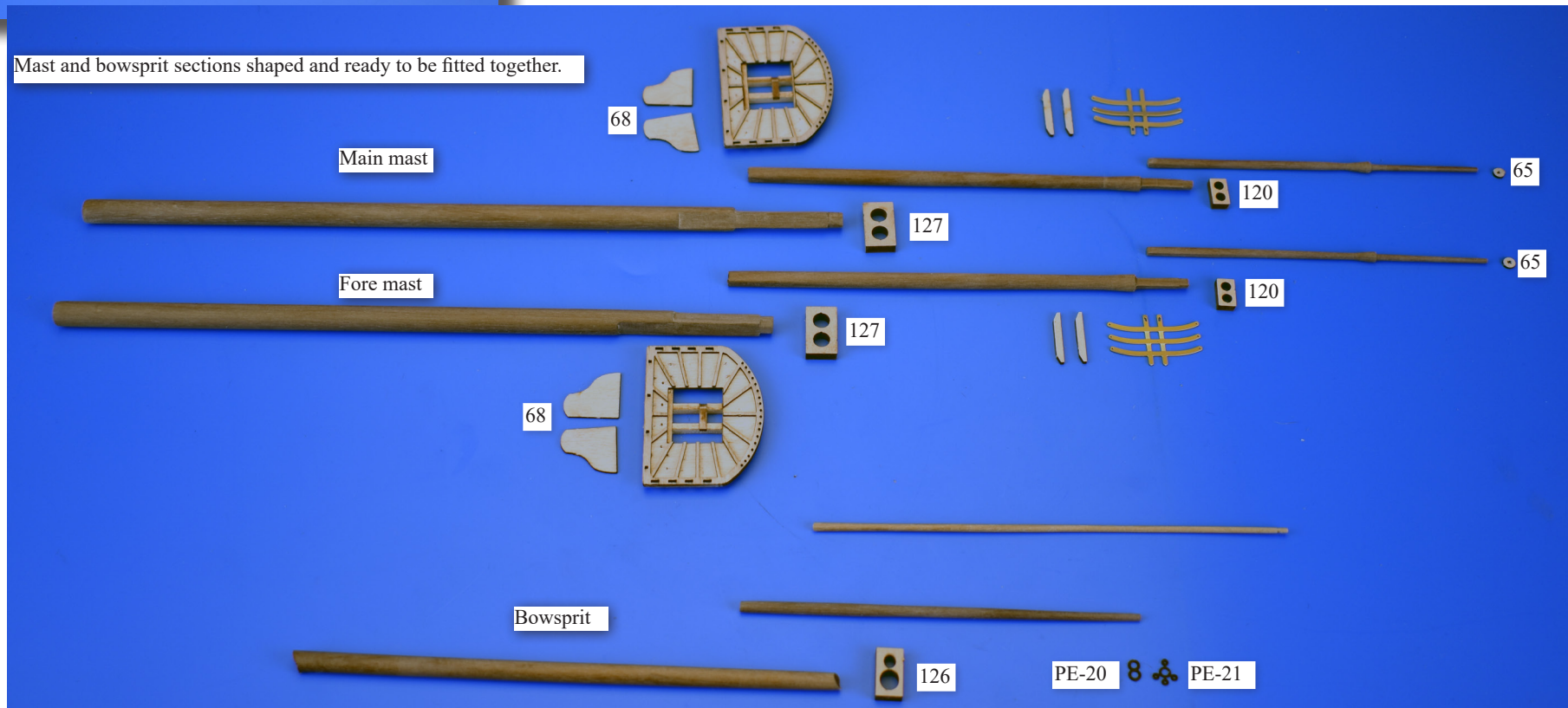

Fore and main lower masts and tops with cheeks in place



65

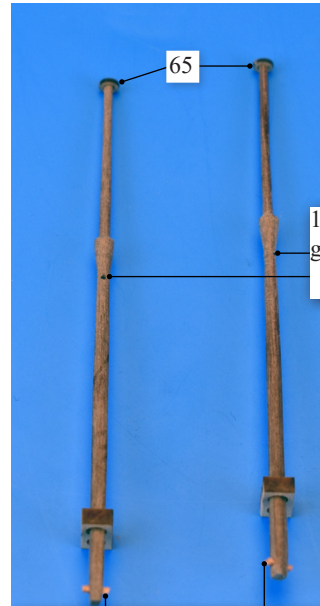

1mm hole for topgallant yard tie

Fore and main topgallant masts showing the lower ends with main caps in place, followed by the 'fids' or stoppers.

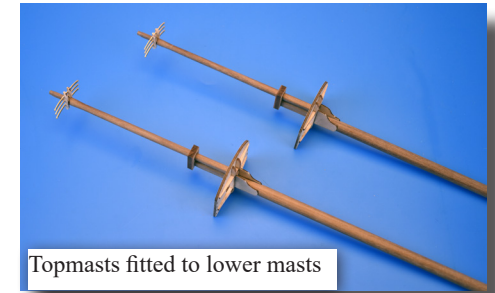

Topmasts fitted to lower masts

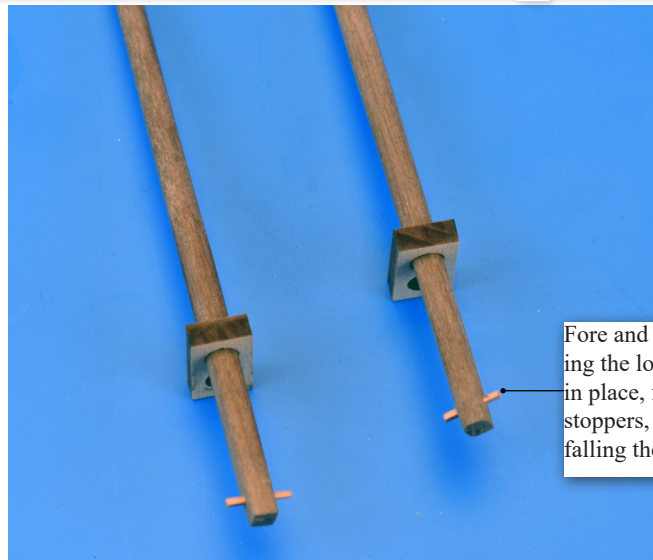

Fore and main top masts showing the lower ends with main caps in place, followed by the 'fids' or stoppers, which stop the mast from falling through the lower trestle trees.

Right - Bowsprit, fore and main masts built up. Note the pin in the end of the flying jibboom (the unattached slim long tapered dowel next to the bowsprit). This pin will be fixed into the front face of the bowsprit cap to secure the part.



When the basic mast and bowsprit assemblies are complete, paint the areas shown here (and on the plans) black. These masts and bowsprit were masked and sprayed black

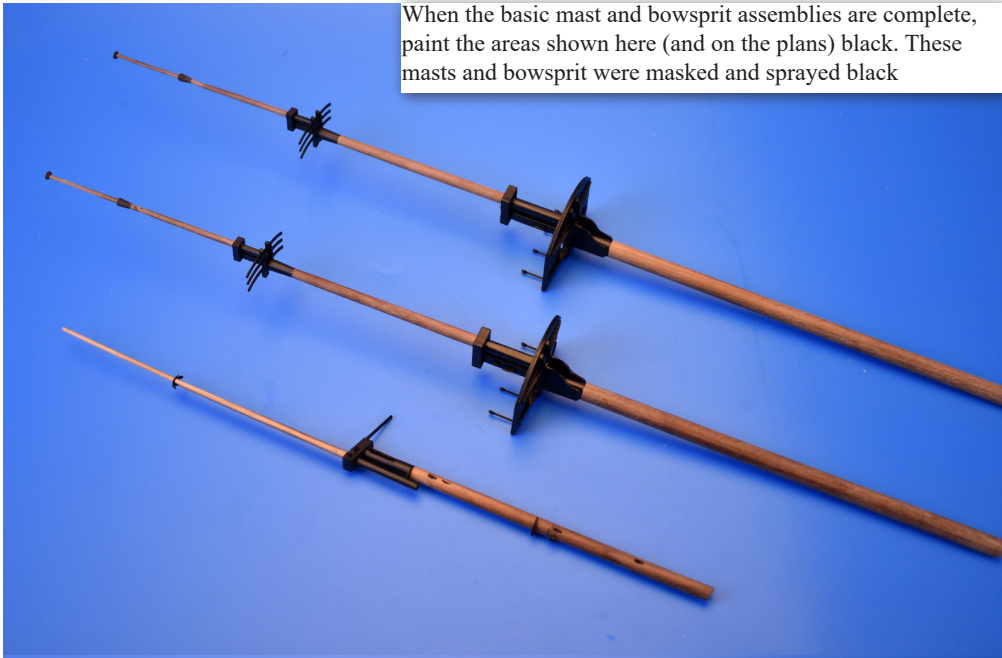

Once painted, the mast rings can be added using black cartridge paper, as shown on the full size plans. The unpainted fore and main top rails can be added.

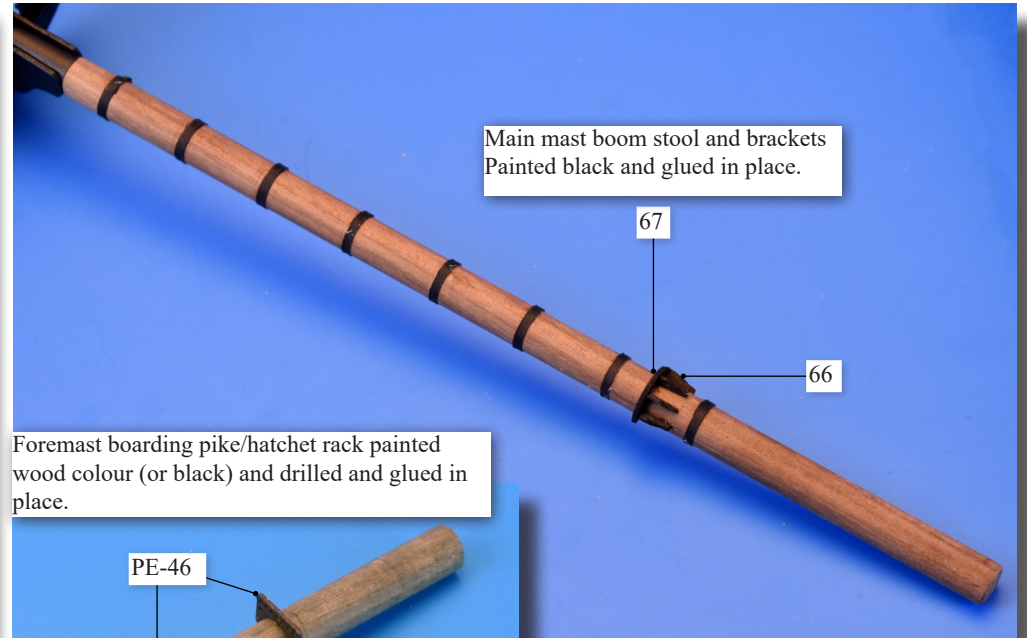
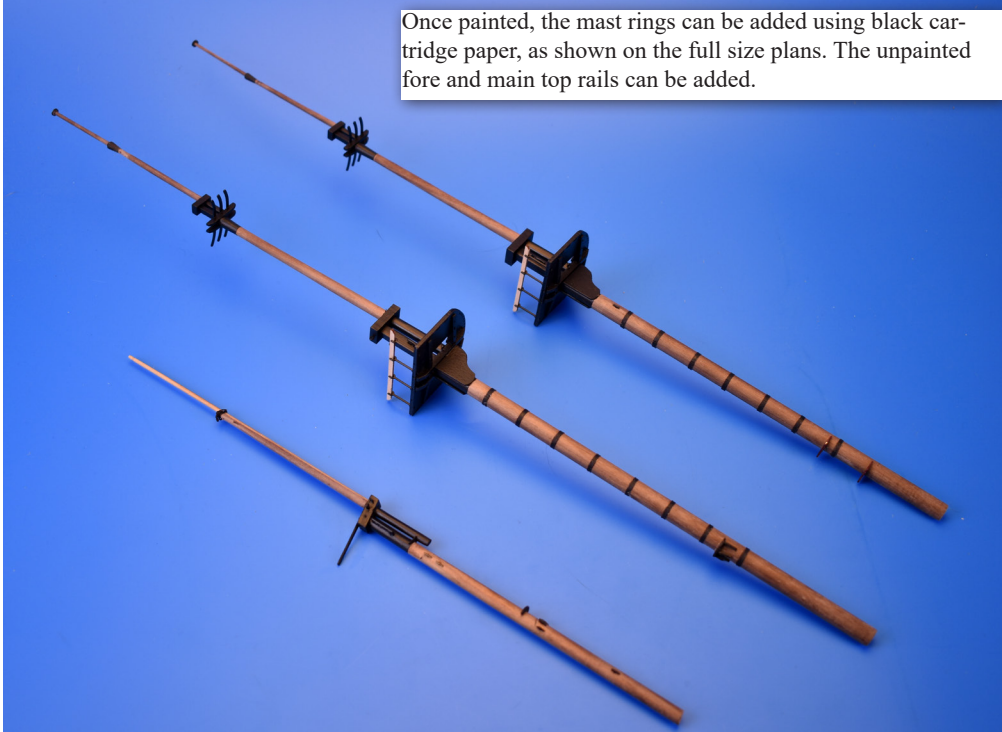

Main mast boom stool and brackets  
Painted black and glued in place.

67

66

Foremast boarding pike/hatchet rack painted wood colour (or black) and drilled and glued in place.

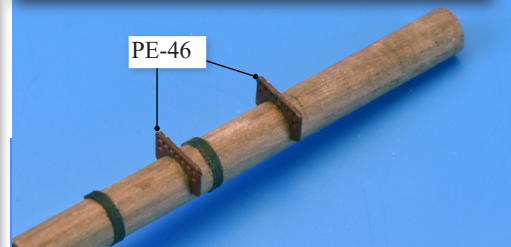

PE-46

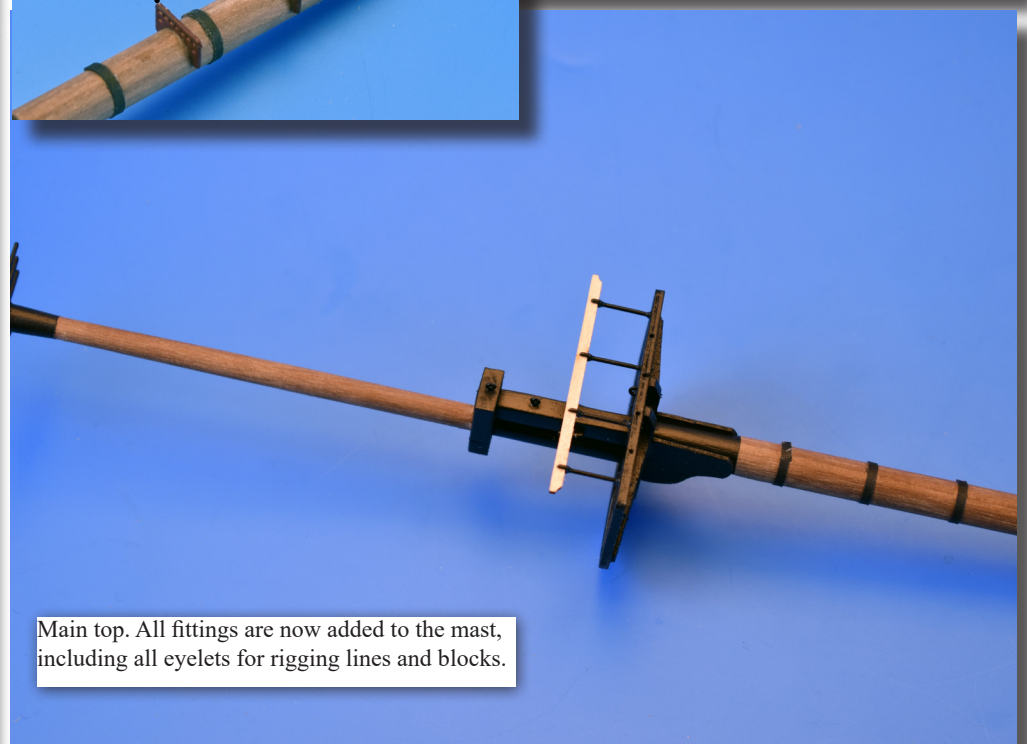

Main top. All fittings are now added to the mast, including all eyelets for rigging lines and blocks.

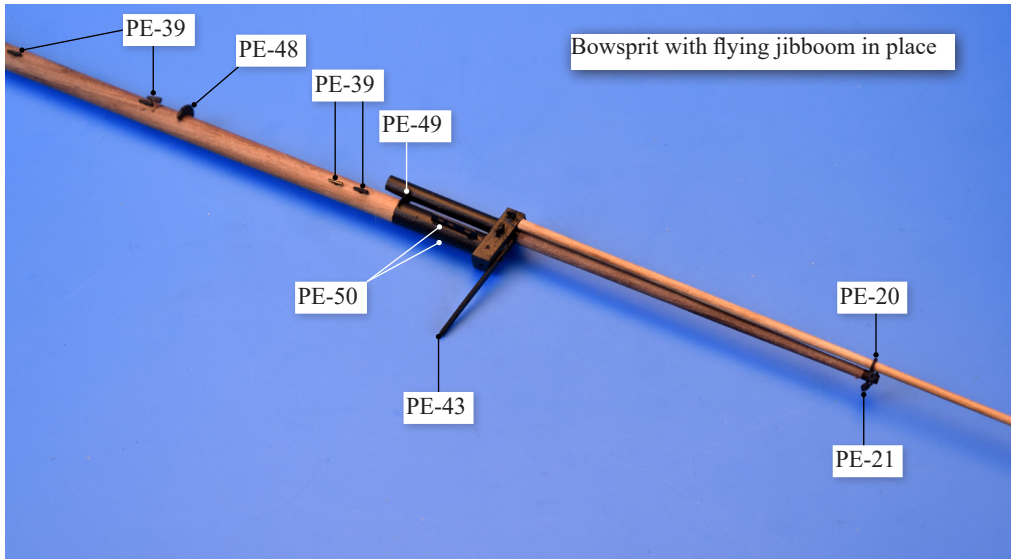

All yards and stun sail booms tapered and sanded. The fore and main yards are the same size.



Left- Add all photo etched fittings to the yards, using the full size plans for reference.

Below - Paint all yards black except for the fore and main stun sail booms

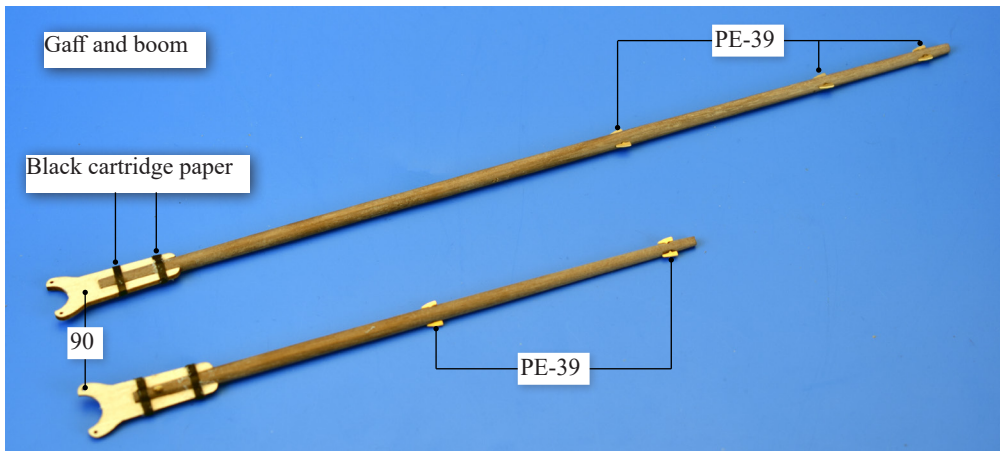

One yards and booms have been painted, add the stun sail booms to the fore and main lower and upper yards, and then add all blocks and footropes, using the plans for reference.



The spritsail yard can be rigged in place at this stage

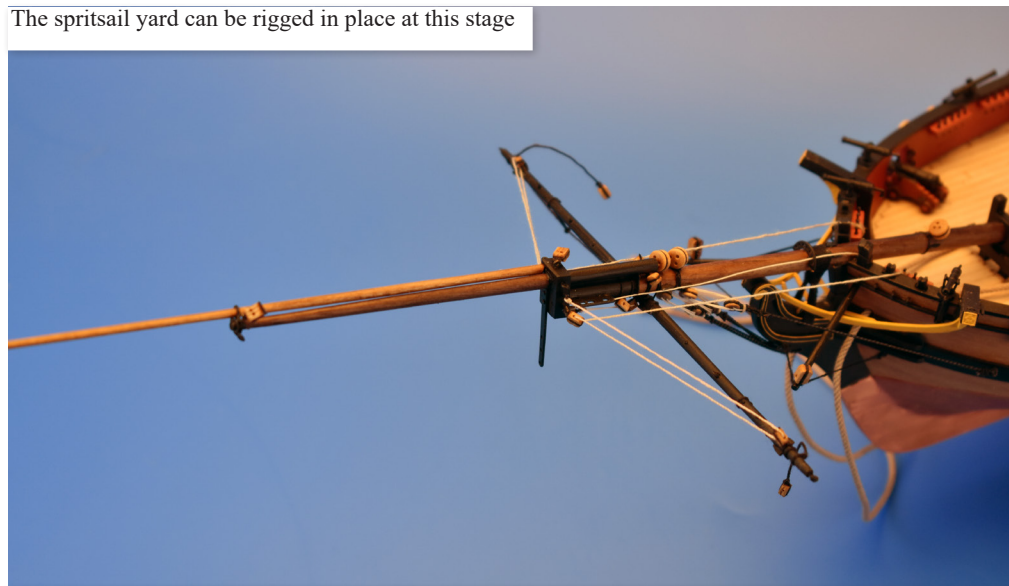

Below - Fore and main mast permanently stepped in place with a drop of PVA added to the bottom of the masts to secure them in place, and prevent any turning of the masts during the rigging process.



The bowsprit is added first. Start with the gammoning and then rig the bowsprit stays, as shown below and detailed in the rigging plans

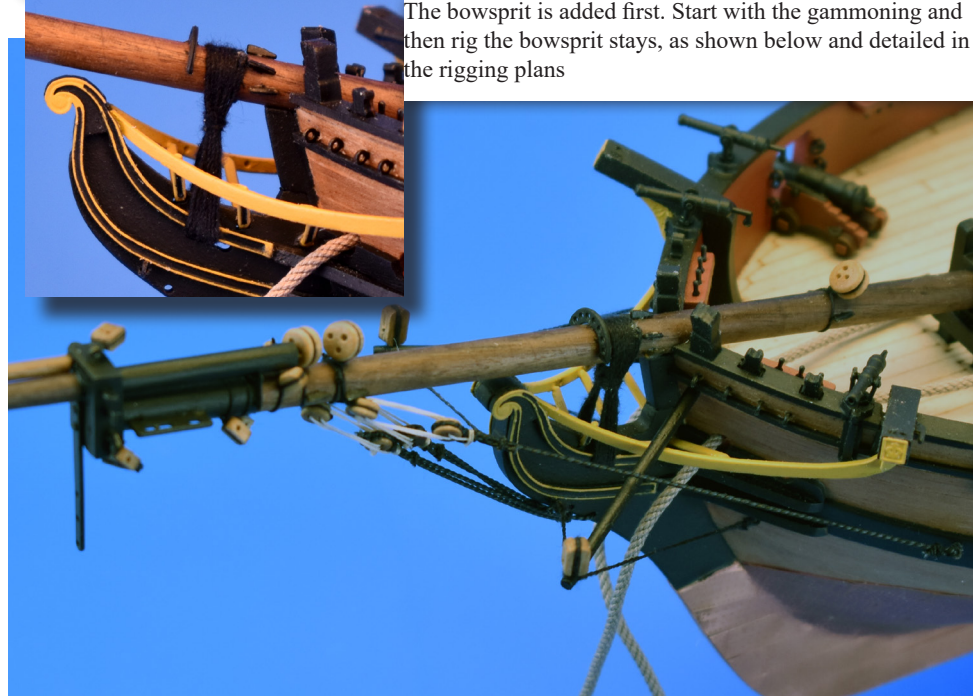





Shroud sequence (The pictures are a compliment to the main rigging drawings, use the drawings for correct rigging line and deadeye/block sizes and placement)

Above - Lower shrouds are added first. Do not over tension any lines when rigging the lanyards to the deadeyes, even if this means that some shrouds are a little less taught than others.

Below - Once the lower shrouds have been set up, the 'Futtock Stave' can be added each side. These are simply 1mm brass rod cut overlong and tied in place to each of the shrouds. Carefully measure the distance from the lower tops to ensure both sides are aligned correctly. It is very easy to have one side higher or lower than the other.



Above - To pull the top of the lower shrouds into the mast, 'catharpins' are rigged. These are simply thread secured to the left and right futtock staves.

Below - Make up 16 sets of 'Futtock Shrouds' These are black thread with a futtock hook tied into one end. Cut each to a length of approximately 80-90mm.

Right - The futtock shrouds hooked in place to the futtock strops. The lower end is secured to the shrouds, just below the futtock stave.

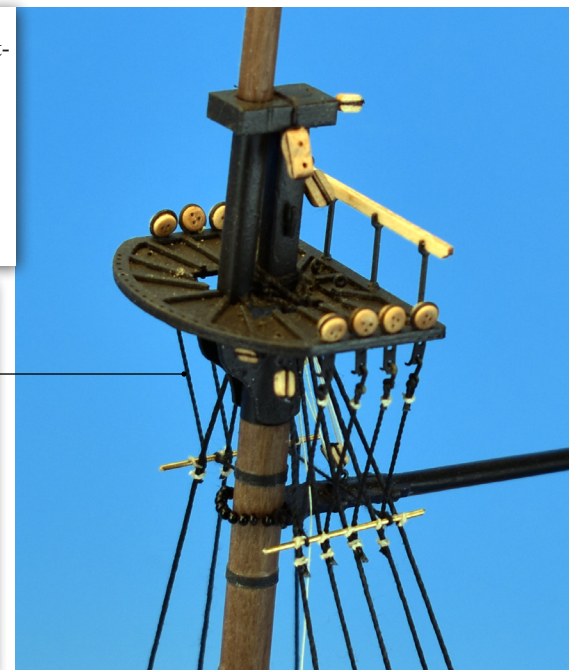
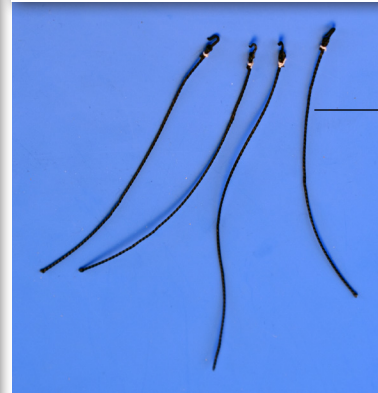

Below - Topmast shrouds added, followed by the upper futtock staves (0.5mm brass rod) and catharpins.

Right - Note the single 3mm block tied to the first and second topmast shrouds. This applies to both fore and main topmasts, and is for the topsail yard lifts.

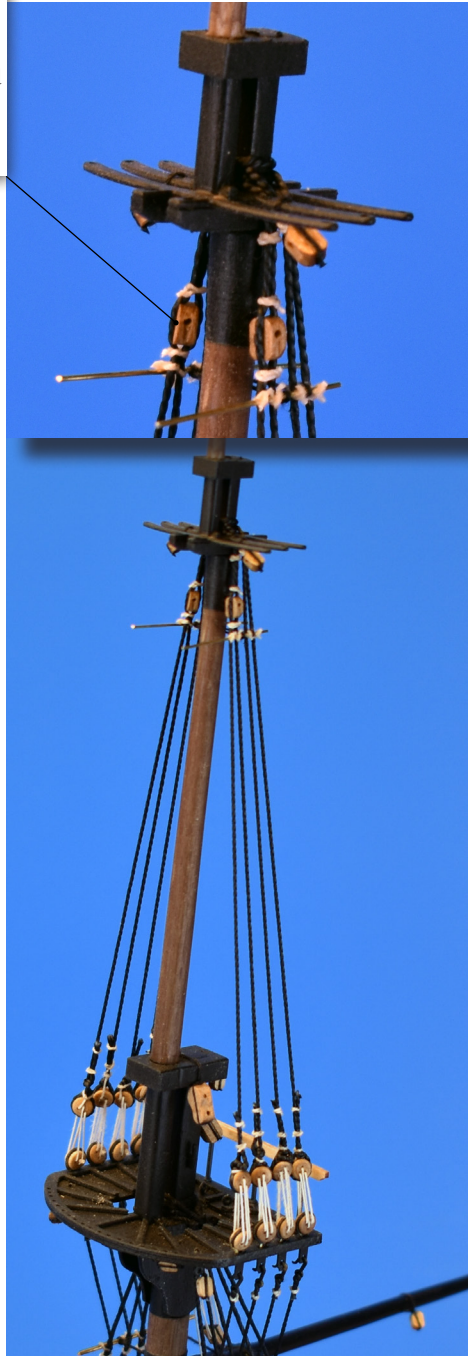

Ratlines tied into place. Before applying watered down PVA wood glue to the end knots, to secure them permanently in place, pull the excess ends of the ratlines to ensure the shrouds are not pulled in from the clove hitch knots of the ratlines.

Below - Brushing on watered down PVA wood glue to secure ratlines on first and last shrouds.

Below right - Once the PVA has cured, snip off the excess ratlines using scissors or a pair of side cutters.

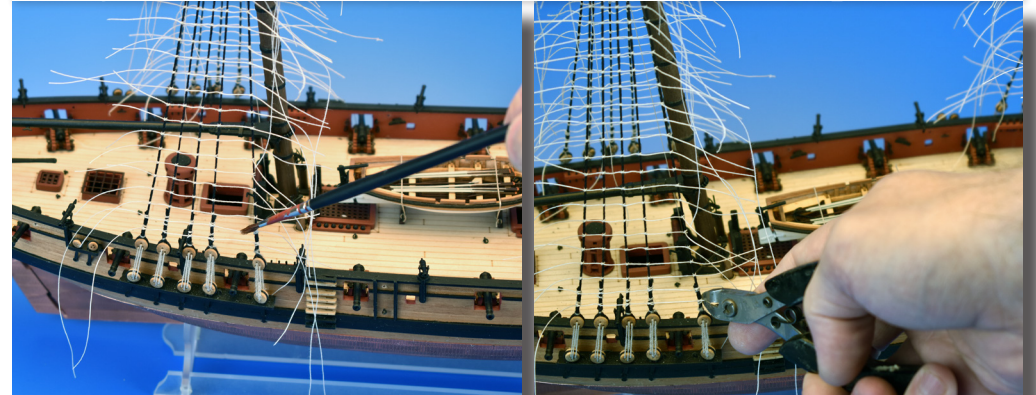



Above - ratlines now trimmed, ready for staining black.

Below - To make sure so black paint or ink splashes onto the model, add paper behind the shrouds to help prevent this. The prototype model shown had the ratlines stained by brushing on Black Indian Ink. The futtock staves were then painted black.

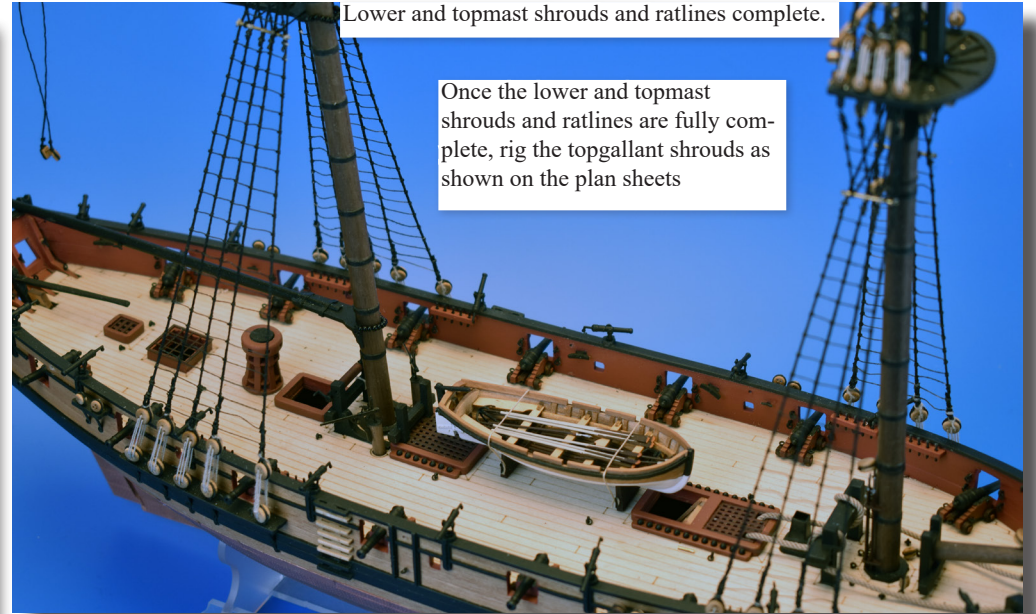
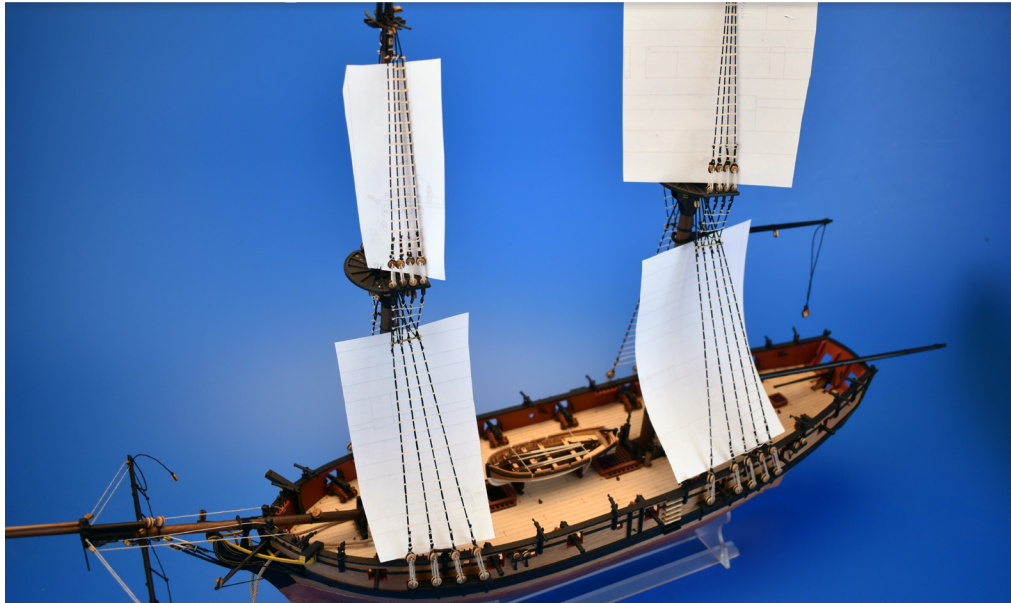

Lower and topmast shrouds and ratlines complete.

Once the lower and topmast shrouds and ratlines are fully complete, rig the topgallant shrouds as shown on the plan sheets

Below - Not that the shrouds and ratlines are set up, add the yards to their respective positions on the masts. use the plans for correct positioning and the methods use to fix each yard in place. The yards shown below are the lower yards, with the parral ribs and beads added, ready for fixing to the lower masts



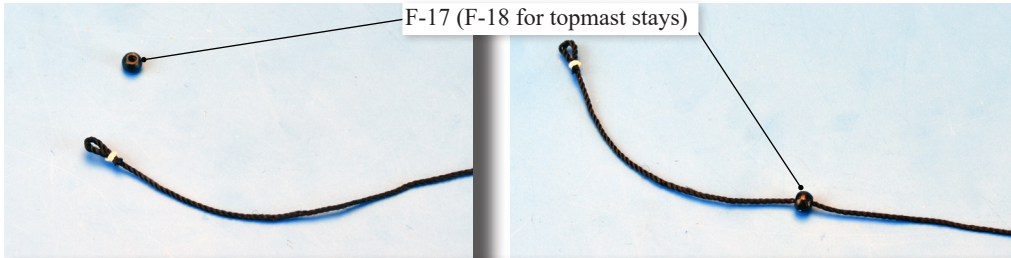

F-17 (F-18 for topmast stays)

Lower mast stays. Above, The method of simulated the stay collar and mouse. The 'Mouse' is F-17 for the lower stays, and the smaller F-18 is for the topmast stays.

Below - The main and fore stays and preventer stays set up. At the top, each is secured to the mast heads with the collar and mouse and at the lower end, 5mm deadeyes and lanyards.

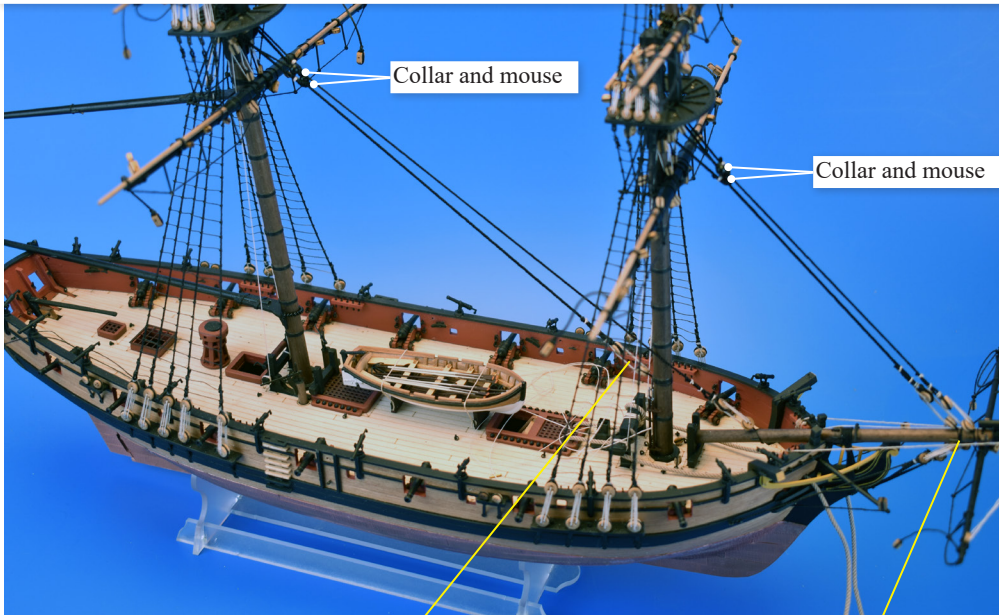

Collar and mouse

Collar and mouse



Above and below - Before adding the topmast stays, rig the topmast back stays



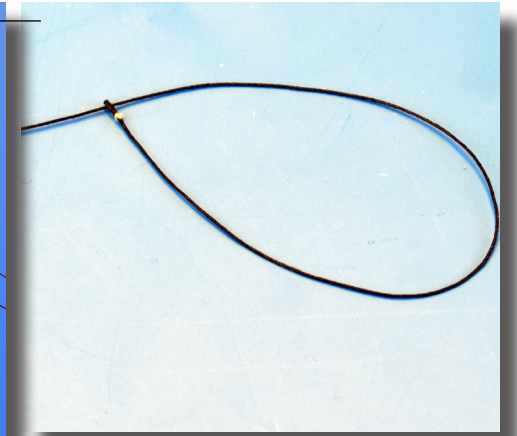
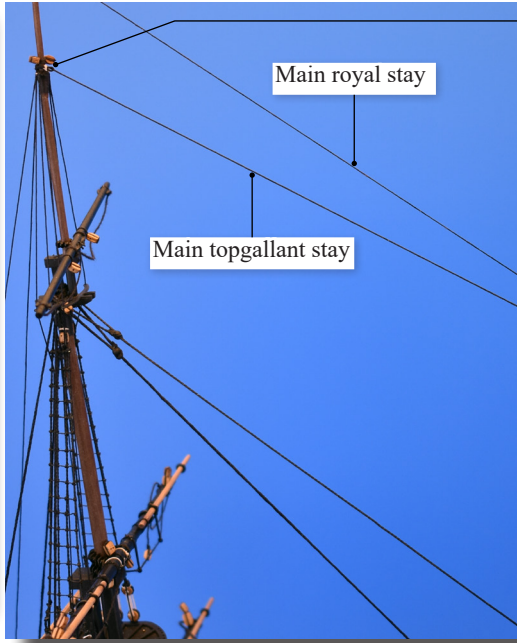

Topgallant and royal stays. The top end of each stay is attached to the mast heads using the method shown above. Use the line drawings on the plans for securing the standing ends of each stay

Above Main topmast stay and preventer stay. The collar and mouse at the mast head end is set up as the lower mast stays, except the 'mouse' is the smaller F-18.  
 Below - Fore topmast stay and preventer stay. The ends of the stays run through the 'bees' near the bowsprit cap and down to the forecastle, where they are set up with blocks and tackle, as shown in the line drawings on the plans.





Once the black standing rigging is complete, start on the running rigging. Start at the lowest yards (as shown above and left), work from inwards to the ends of the yards, and work upwards to the upper yards.

It is highly recommended that you do not add the lower yard sheets and tack rigging lines until the rest of the rigging is complete. The same applies to the main brace rigging. This is because the rigging lines will block access to the deck, and severely hinder the belaying of other rigging lines. Also, before adding the final rigging lines, if you have not already added the boat to the deck, do this before adding the lower sheets, tacks and main brace.

As with the standing rigging, do not make any rigging line too taut, as this can bend the yards and masts, more so for the smaller diameter upper masts.



Once the rigging is fully complete, the anchors can now be lashed in place. Use the photos above and below for the recommended lashing positions.

With the anchors in place, the model of Speedy should now be complete.

Carefully look over the model and remove any loose rigging thread or stray parts that may still be present.





HM Brig Sloop Speedy – 1:64<sup>th</sup> scale

PARTS LIST

<u>Pt. No</u>	<u>Description</u>	<u>Material</u>	<u>QTY</u>				
				C1	18 Foot Cutter Frame base	2mm MDF	1
				C2	18 Foot Cutter Frame	2mm MDF	1
				C3	18 Foot Cutter Frame	2mm MDF	1
				C4	18 Foot Cutter Frame	2mm MDF	1
				C5	18 Foot Cutter Frame	2mm MDF	1
				C6	18 Foot Cutter Frame	2mm MDF	1
				C7	18 Foot Cutter Frame	2mm MDF	1
				C8	18 Foot Cutter Frame	2mm MDF	1
				C9	18 Foot Cutter Frame	2mm MDF	1
				C10	18 Foot Cutter Keel	2mm MDF	1
				C11	18 Foot Cutter bow planking pattern	2mm MDF	2
				C12	18 Foot Cutter cradle (Fore)	2mm MDF	1
				C13	18 Foot Cutter cradle (Aft)	2mm MDF	1
		<b>3mm MDF</b>					
1	False Keel	3mm MDF	1				
2	Bulkhead	3mm MDF	1				
3	Bulkhead	3mm MDF	1				
4	Bulkhead	3mm MDF	1				
5	Bulkhead	3mm MDF	1				
6	Bulkhead	3mm MDF	1				
6a	Deck Beam	3mm MDF	2				
7	Bulkhead	3mm MDF	1				
7a	Deck Beam	3mm MDF	1				
8	Bulkhead	3mm MDF	1				
8a	Deck Beam	3mm MDF	1				
9	Bulkhead	3mm MDF	1				
9a	Deck Beam	3mm MDF	2				
10	Bulkhead	3mm MDF	1				
11	Bulkhead	3mm MDF	1				
11a	Deck Beam	3mm MDF	1				
12	Bulkhead	3mm MDF	1				
12a	Deck Beam	3mm MDF	1				
13	Bulkhead	3mm MDF	1				
14	Bulkhead	3mm MDF	1				
15	Bulkhead	3mm MDF	1				
16	Bulkhead	3mm MDF	1				
17	Bow Pattern (Inner)	3mm MDF	2				
18	Bow Pattern (Outer)	3mm MDF	2				
19	Bow patterns (Between bulkheads 3&4)	3mm MDF	2				
20	Bow patterns (Between bulkheads 2&3)	3mm MDF	2				
21	Stern patterns (Between bulkheads 14&15)	3mm MDF	2				
22	Fore/aft lower deck step pattern	3mm MDF	2				
23	Upper deck longitudinal support	3mm MDF	2				
24	Securing peg (To keep keel parts in place)	3mm MDF	4				
25	Sacrificial building cradle (Fore)	3mm MDF	1				
26	Sacrificial building cradle (Aft)	3mm MDF	1				
27	Sacrificial building cradle spacer	3mm MDF	1				
		<b>2mm MDF</b>					
28	Lower deck (Fore)	2mm MDF	2				
29	Lower deck (Aft)	2mm MDF	2				
30	Stern frame pattern (Inner)	2mm MDF	2				
31	Stern frame pattern (Outer)	2mm MDF	2				
						<b>3mm Clear Acetate</b>	
				32	Display cradle (Fore)	3mm Clear Acetate	1
				33	Display cradle (Aft)	3mm Clear Acetate	1
				34	Display cradle spacer (Centre)	3mm Clear Acetate	1
				35	Display cradle spacer (Sides)	3mm Clear Acetate	2
						<b>0.8mm Plywood</b>	
				36	Main deck	0.8mm Plywood	1
				37	Side bulwark pattern (Fore)	0.8mm Plywood	2
				37a	Side bulwark pattern (Aft)	0.8mm Plywood	2
				38	Stern counter	0.8mm Plywood	1
				39	Stern board	0.8mm Plywood	1
				40	Upper rail and swivel gun post pattern (Fore)	0.8mm Plywood	2
				40a	Swivel gun post support timber	0.8mm Plywood	2
				40b	Swivel gun post support timber	0.8mm Plywood	2
				41	Upper rail and swivel gun post pattern	0.8mm Plywood	2
				41a	Swivel gun post support timber	0.8mm Plywood	2
				41b	Swivel gun post support timber	0.8mm Plywood	2
				42	Upper rail and swivel gun post pattern	0.8mm Plywood	2
				42a	Swivel gun post support timber	0.8mm Plywood	2
				42b	Side fender timber	0.8mm Plywood	4
				42c	Swivel gun post support timber	0.8mm Plywood	2
				43	Upper rail and swivel gun post pattern	0.8mm Plywood	2
				43a	Swivel gun post support timber	0.8mm Plywood	2
				43b	Swivel gun post support timber	0.8mm Plywood	2
				44	Upper rail and swivel gun post pattern	0.8mm Plywood	2
				44a	Swivel gun post support timber	0.8mm Plywood	2
				44b	Swivel gun post support timber	0.8mm Plywood	2
				45	Hair bracket	0.8mm Plywood	2
				46	Bow main rail	0.8mm Plywood	2
				47	Capstan lower chock	0.8mm Plywood	1
				48	Capstan upper chock	0.8mm Plywood	1





116	Main Bitt Post (Front of mast)	3mm Wood	2	PE-21	Jibboom eyebolt ring	0.4mm Photo Etch	1
117	Main Bitt Post cross beam (Front of mast)	3mm Wood	1	PE-22	Aft skylight frame	0.4mm Photo Etch	1
118	Main Bitt Post (Aft of mast)	3mm Wood	2	PE-23	Deck pump main body	0.4mm Photo Etch	2
119	Main Bitt Post cross beam (Aft of mast)	3mm Wood	1	PE-24	Deck pump main body side frame	0.4mm Photo Etch	4
120	Fore and Main lower top mast cap	3mm Wood	2	PE-25	Deck pump top cap	0.4mm Photo Etch	2
121	Anchor Stock	3mm Wood	4	PE-26	Nameplate	0.4mm Photo Etch	2
122	Bow Timberhead	3mm Wood	2	PE-27	Hatchet	0.4mm Photo Etch	6
<b>4mm Wood</b>				CPE-1	18 Foot Cutter main floor	0.4mm Photo Etch	1
				CPE-2	18 Foot Cutter fore grating	0.4mm Photo Etch	1
				CPE-3	18 Foot Cutter aft grating	0.4mm Photo Etch	1
				CPE-3	18 Foot Cutter aft grating	0.4mm Photo Etch	1
				CPE-4	18 Foot Cutter stern grating	0.4mm Photo Etch	1
				CPE-5	18 Foot Cutter mast strap	0.4mm Photo Etch	1
123	Fore Bitt post	4mm Wood	2	CPE-6	18 Foot Cutter rudder side (Left)	0.4mm Photo Etch	1
124	Fore Bitt post cross beam	4mm Wood	1	CPE-7	18 Foot Cutter rudder side (Right)	0.4mm Photo Etch	1
125	Cathead	4mm Wood	2	CPE-8	18 Foot Cutter small kedge anchor stock	0.4mm Photo Etch	2
126	Bowsprit cap	4mm Wood	1	CPE-9	18 Foot Cutter small kedge anchor top	0.4mm Photo Etch	2
127	Fore and main lower mast cap	4mm Wood	2	CPE-10	18 Foot Cutter pike shaft	0.4mm Photo Etch	2
<b>0.8mm Laser Engraved Plywood</b>				CPE-11	18 Foot Cutter oar	0.4mm Photo Etch	6
128	Deck with planking	0.8mm Plywood	1	<b>0.6mm Photo Etched Brass</b>			
<b>0.2mm Photo Etched Brass</b>				PE-28	Yard footrope stirrup	0.6mm Photo Etch	26
				PE-29	Belaying pin	0.6mm Photo Etch	50
PE-1	Hair bracket decoration (Left)	0.2mm Photo Etch	1	PE-30	Small cleat	0.6mm Photo Etch	18
PE-2	Hair bracket decoration (Right)	0.2mm Photo Etch	1	PE-31	Half-Pounder swivel gun handle	0.6mm Photo Etch	24
PE-3	4-Pounder carriage cap square	0.2mm Photo Etch	32	PE-32	Winch drum turning handle	0.6mm Photo Etch	2
PE-4	Lower yard stunsail boom outer bracket	0.2mm Photo Etch	4	PE-33	Bow 'V' shaped vertical rail (Inner)	0.6mm Photo Etch	1
PE-5	Upper yard stunsail boom outer bracket	0.2mm Photo Etch	4	PE-34	Bow 'V' shaped vertical rail (Middle)	0.6mm Photo Etch	1
PE-6	Cathead end cap decoration	0.2mm Photo Etch	2	PE-35	Bow 'V' shaped vertical rail (Outer)	0.6mm Photo Etch	1
<b>0.4mm Photo Etched Brass</b>				PE-36	Lower mast and yard sling cleat	0.6mm Photo Etch	8
				PE-37	Cathead cleat	0.6mm Photo Etch	2
				PE-38	Topsail yard sling cleat	0.6mm Photo Etch	6
PE-7	Open eyebolt (For PE-7a)	0.4mm Photo Etch	80	PE-39	Yard and bowsprit cleat	0.6mm Photo Etch	48
PE-7a	Ring for open eyebolt (For PE-7)	0.4mm Photo Etch	80	PE-40	Stunsail boom outer bracket	0.6mm Photo Etch	8
PE-8	Closed eyebolt	0.4mm Photo Etch	145	PE-41	Lower stunsail yard inner bracket	0.6mm Photo Etch	4
PE-9	Rigging hook	0.4mm Photo Etch	47	PE-42	Upper stunsail yard inner bracket	0.6mm Photo Etch	4
PE-10	5mm Deadeye strop and chain plate	0.4mm Photo Etch	20	PE-43	Dolphin striker	0.6mm Photo Etch	1
PE-11	3mm Deadeye strop and chain plate	0.4mm Photo Etch	10	PE-44	Anchor ring	0.6mm Photo Etch	4
PE-12	3mm Deadeye futtock strop	0.4mm Photo Etch	18	PE-45	Rudder pintle	0.6mm Photo Etch	4
PE-13	3mm Deadeye futtock strop hook	0.4mm Photo Etch	24	PE-46	Foremast boarding pike/hatchet rack	0.6mm Photo Etch	2
PE-14	Topmast parrel rib	0.4mm Photo Etch	24	PE-47	Boarding pike	0.6mm Photo Etch	10
PE-15	4-Pounder carriage 'Traverse Bolt'	0.4mm Photo Etch	16	PE-48	Bowsprit fairlead cleat	0.6mm Photo Etch	1
PE-16	Euphroe block (Only for pre-1800 version)	0.4mm Photo-Etch	2	PE-49	Jibboom saddle	0.6mm Photo Etch	1
PE-17	Drum windlass pawl	0.4mm Photo Etch	2	PE-50	Bowsprit bee (Sheaves for topmast stays)	0.6mm Photo Etch	2
PE-18	Half-Pounder swivel gun bracket	0.4mm Photo Etch	21	PE-51	Fore and main lower top stanchion	0.6mm Photo Etch	8
PE-19	Stove flue	0.4mm Photo Etch	1	PE-52	Fore topmast crosstrees	0.6mm Photo Etch	1
PE-20	Jibboom/Flying Jibboom bracket	0.4mm Photo Etch	1	PE-53	Main topmast crosstrees	0.6mm Photo Etch	1

PE-54	Fore hatch grating	0.6mm Photo Etch	1				
PE-55	Main hatch grating	0.6mm Photo Etch	1	F-19	0.1mm Diameter natural thread	DD 50//8243	50m
PE-56	Bread hatch grating	0.6mm Photo Etch	1	F-20	0.25mm Diameter natural thread	DD 36//8243	40m
				F-21	0.5mm Diameter natural thread	DD 25//8243	20m
				F-22	0.75mm Diameter natural thread	DD 50//8243	10m
				F-23	0.25mm Diameter black thread	DD 50//09770	20m
				F-24	0.5mm Diameter black thread	DD 25//09770	20m
				F-25	0.75mm Diameter black thread	DD 18//09770	20m
				F-26	1mm Diameter black thread	DD 12//09770	20m
				F-27	1.5mm Diameter black thread	DD 8//09770	20m
				F-28	2mm Diameter natural thread (Anchor hawse)	DD 36//8243	0.5m
				F-29	8mm Dowel x 500mm long	Wood	1
				F-30	6mm Dowel x 500mm long	Wood	4
				F-31	5mm Dowel x 500mm long	Wood	4
				F-32	4mm Dowel x 500mm long	Wood	4
				F-33	3mm Dowel x 500mm long	Wood	4
				F-34	2mm Dowel x 500mm long	Wood	2
				F-35	1.5 x 5 x 500mm long Limewood	Wood	30
				F-36	1 x 4 x 500mm long Second planking	Wood	60
				F-37	1 x 3 x 500mm long Second planking	Wood	6
				F-38	1 x 1 x 500mm long wood strip	Wood	1
				F-39	1mm Diameter brass rod x160mm long (Approx.)	Metal	1
				F-40	0.5mm Diameter brass rod x 160mm long (Approx.)	Metal	1
				F-41	Black Cartridge paper (For anchor & mast straps)	Paper	1

### 0.1mm Photo Etched Copper

### Fittings

F-1	Jeer and topsail bits windlass	Casting	1
F-2	Anchor shank	Casting	4
F-3	4 Pounder cannon barrel	Casting	14
F-4	Half-Pounder swivel gun barrel	Casting	20
F-5	1:64 <sup>th</sup> Lord Cochrane figure	Casting	1
F-6	2mm Diameter cannon ball (Stain/paint black)	Steel	50
F-7	Small pin	4136/10	300
F-8	Ladder	4320/01	1
F-9	3.5mm Diameter Sheave	4280/35	10
F-10	5mm Deadeye	4050/05	60
F-11	3mm Deadeye	4050/03	60
F-12	3mm Single block	4070/03	120
F-13	5mm Single block	4070/05	30
F-14	4mm Double block	4080/04	30
F-15	7mm Sister block	4083/05	6
F-16	Parrel bead	Plastic	70
F-17	Large mouse bead (Lower mast stays)	Plastic	6
F-18	Small mouse bead (Upper mast stays)	Plastic	6

### Materials





©Vanguard Models is a subsidiary of Burncroft Limited

Registered Office:

70B, High Street

Cinderford

Gloucestershire

GL14 2SZ

UK

Tel (0044) [0]1594 824610

Registered company number – 04317996

Website - [www.vanguardmodels.co.uk](http://www.vanguardmodels.co.uk)

Email - [sales@vanguardmodels.com](mailto:sales@vanguardmodels.com)

The Speedy was designed and developed in the UK by Chris Watton