

**RTR**

# BRUSHED MOTOR BOAT

## ASSEMBLY AND OPERATION MANUAL

### Specifications:



Model No: 9321 Offshore Infinity Deep Vee

Total Length..... 620mm(24.5in)  
Beam ..... 165mm(6.5in)  
Speed ..... 40+KPH



Model No: 9322 Blue Mania Catamaran

Total Length ..... 570mm(22.5in)  
Beam ..... 195mm(7.7in)  
Speed ..... 40+KPH

### Universal Assembly:

Motor ..... Water cooled 550 brushed motor(included)  
Radio System ..... 2.4G 2CH Digital Proportional Transmitter(Included)  
Speed Control ..... Water cooled & water proof 30A Brushed ESC w/ BEC (Included)  
Drive System ..... 3mm Flex Cable Direct Drive  
Battery ..... 11.1V 1300mAh 35C LiPo Pack(Optional part)  
Charger..... 2S/3S Balance charger with DC adapter(Optional part)  
Transmitter Battery..... 4pcs of AA Alkaline batteries(Not Included)

**IMPORTANT: THESE MODELS ARE CAPABLE OF OVER 40 KPH, PERSONAL INJURY OR PROPERTY DAMAGE MAY RESULT FROM MISUSE OF THESE PRODUCTS, TAKE CARE AND ENJOY OUR MODEL RESPONSIBLY.**

## Introduction

Thank you for purchasing Joysway brushed motor boat ! This manual contains the instructions you need to safely prepare, operate, and maintain your R/C boat. Read over this manual thoroughly before operating Joysway brushed motor boat.

## Safety Precautions

- Operating care to avoid touching the propeller anytime the motor is operating. If your fingers, hands, etc. come in contact with the spinning propeller, you may be severely injured. This model is capable of inflicting property damage and severe personal injury if a collision occurs. Racing your boat responsibly, stay clear of people, full-scale boats and wildlife.
- The metal hardware on your boat can be sharp. Be careful handling the parts.
- The brushed motor may become hot. After a run allow the motor to cool before touching it.

## Specifications & Description Changes

All pictures, descriptions, and specifications found in this instruction manual are subject to change without notice. Joysway maintains no responsibility for inadvertent errors in this manual.

## Items Required For Completion & Battery Pack Recommendations

You will need to purchase the following items to operate your Joysway brushed motor boat. We highly recommend the use of the following products.

### *Battery Recommendation*

One pack of 11.1V 1300mAh 35C LiPo Pack or higher capacity LiPo.

**NOTE:** If you have existing 11.1V Lipo battery pack, you can update them for use by changing the connector to Deans connector which is included in the kits bag, be sure to solder the connector to the battery in the proper polarity. (1 Male Deans connector is already soldered with the ESC, the other 1 Female Deans connector is included in the kits bag)

### *Charger Recommendation*

2S/3S Balance Charger and adapter, or multi-functional intelligent charger.

**NOTE:** You will also need 4 "AA" alkaline batteries for the transmitter.

## Contents Of Set

- Water cooled 550 brushed motor (Pre-installed)
- 30A Water cooled & water proof brushed ESC w/ BEC (Pre-installed)
- Powerful Steering 9g metal gear servo (Pre-installed)
- 2.4GHz 2CH Pistol Transmitter
- Laser cut plywood boat stand

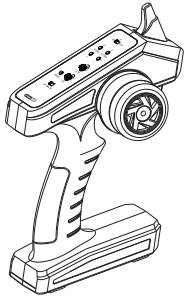

Offshore Infinity Deep Vee



Blue Mania Catamaran

### kits bag contents:

1 Deans Plugs W/  
1 Heat Shrinking Tube

2 pcs of Allen Key  
(2.5mm,2mm)

Spare P1.4XD37 three  
blade nylon propeller

Water proof  
ballon for RX

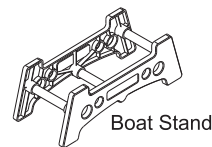

Boat Stand

8mm Spanner  
(NOT INCLUDED)

## Circuit & Cooling System Diagram

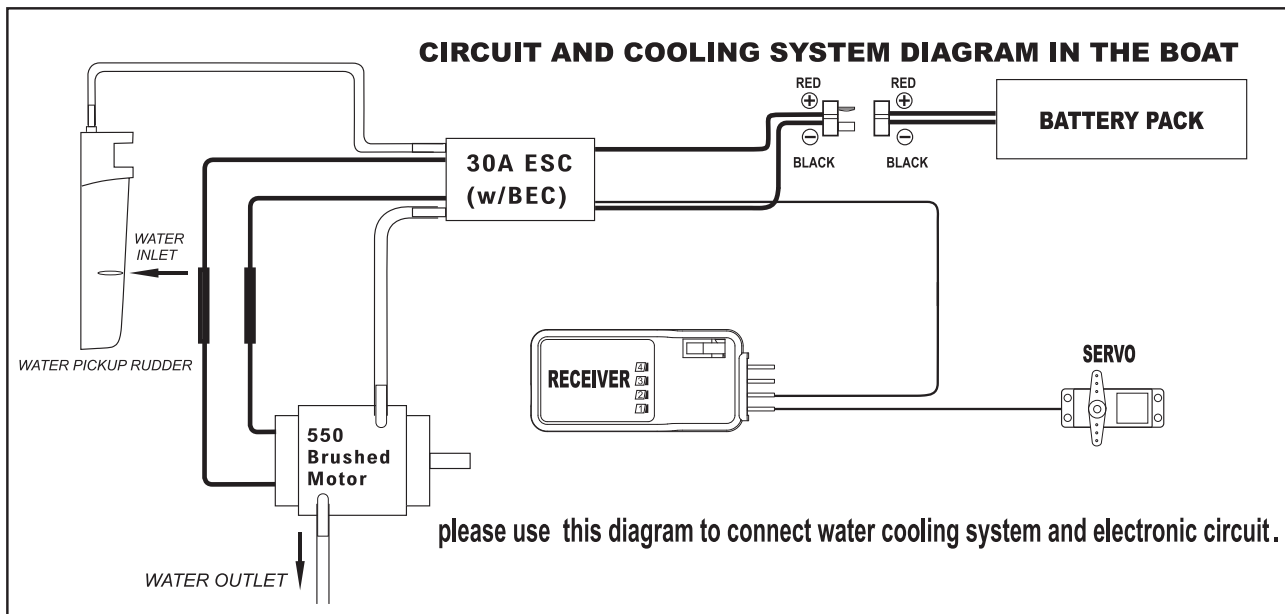

## Preparing Your Boat For Operation

### Assembling the boat stand

Insert three ABS pipes into the holes of two boat stands shown as photos, compress boat stands and ABS pipes tightly, then stick EVA to the four angles, this will protect the hull bottom from scratches during construction and storage.

**NOTE:** Offshore infinity deep vee and Blue mania catamaran boat use the same boat stand.

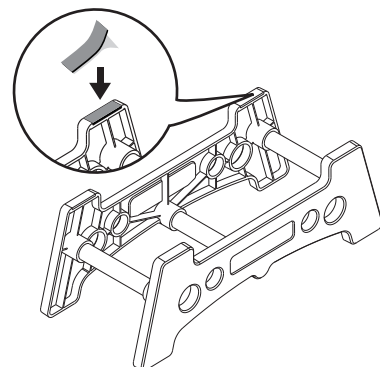

## Installing transmitter batteries

**NOTE:** The transmitter is not water resistant and should never come in contact with water.

1. Install four fresh “AA” batteries. Follow the diagram located in the bottom of the battery tray for proper battery orientation.
2. Turn the transmitter “ON”. The battery light should glow bright RED.

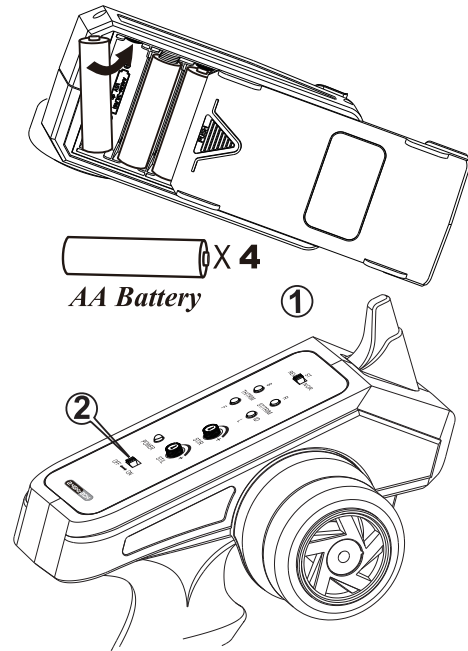

## Receiver connection diagram

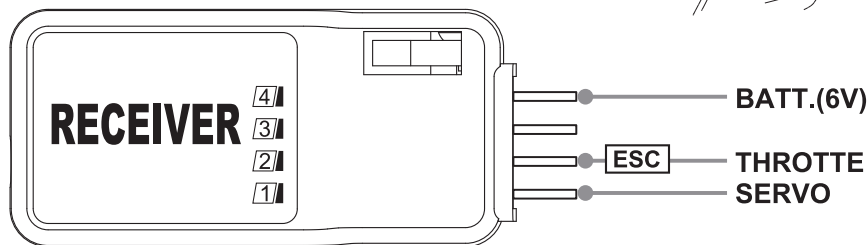

Note: If ESC with BEC function, no need to connect battery with receiver.

**Caution: Before racing boat, Please use ballon supplied in tool bag to wrap receiver for water proof**

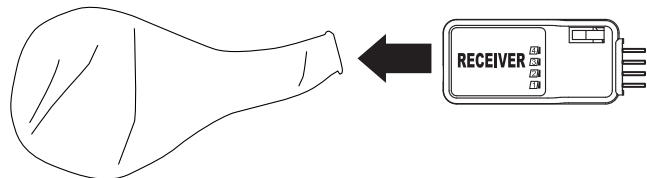

## Installing the Battery

1. Rotate the plastic lock on hatch 90 degrees either to left or right.
2. Lift up and remove the hatch.
3. Attach battery connector to the matching connector of ESC. Do not force them together, they only attach in one way.

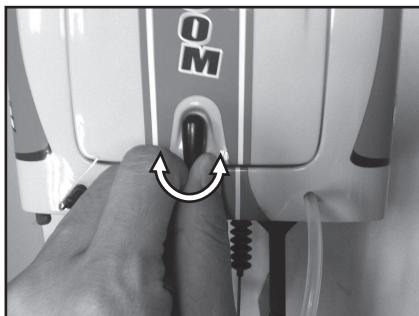

**NOTE:** We recommend you 1 pack of 11.1V 1300mAh 35C Lipo battery for maximum performance. Using the Provided velco strap which is already tied on the battery locators inside the hull to tie the battery. The battery locators help align the batteries for the best running center of gravity for maximum performance. Below are the batteries location inside the hull.

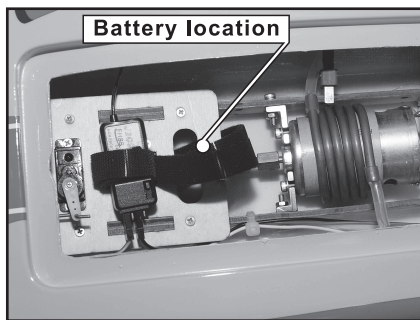

Offshore Infinity Deep Vee battery locator

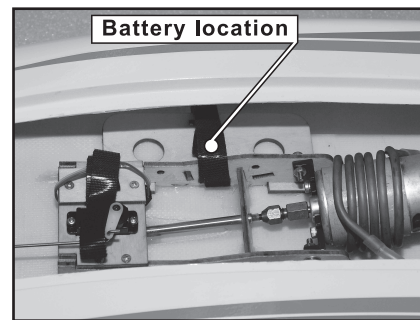

Blue Mania Catamaran battery locator

**NOTE:** 1. There is a water proof rubber ring glued along the slot of hull, always make sure it's secured positioned before re-position the upper deck.

### TRANSMITTER/RECEIVER BINDING

The binding process effectively ties the transmitter and receiver together. Under normal circumstances, both items are supplied like this from the factory. If, however, you find that your transmitter and receiver are not bound (receiver's red LED is on), you should do the following:

- 1) Switch "ON" the transmitter.
- 2) Switch "ON" the receiver by connecting battery to ESC, and ESC cord is plug into Receiver properly (Note: ESC has BEC function).
- 3) Press down the "BIND" button on the receiver, the receiver's green LED will be on to indicate that binding has been successful and the receiver will now accept commands from the transmitter.

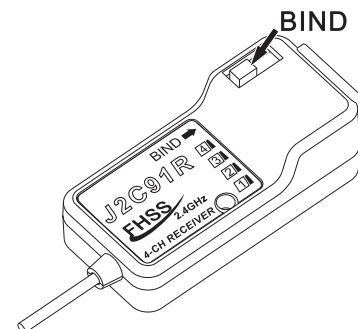

Note 1: During binding process, transmitter and receiver should be no more than one meter apart and no other similar devices should be within 10 meters.  
 Note 2: if the green light flashing, showing the binding failure, please do again as above indication.

### Checking the radio system

1. Always turn the power "ON" to the transmitter before connecting the batteries with the ESC.
2. Attach battery connector to the matching connector of ESC. Do not force them together, they only attach in one way.

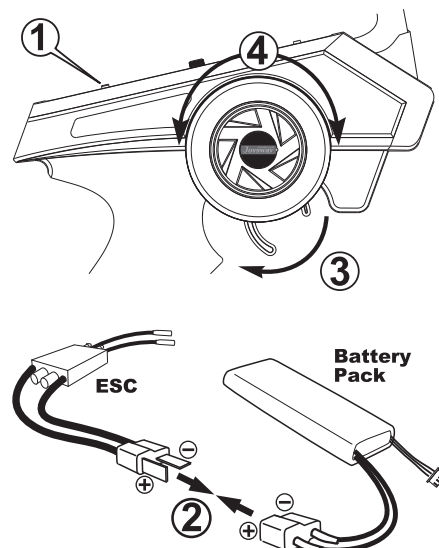

3. Pull the throttle & motor rotate in anticlockwise direction, your motor is now armed and ready for operation.

4. Check the direction of the rudder, the trailing edge of the rudder should turn right when right input is given. Conversely, when left input is given, the trailing edge of the rudder should turn left.

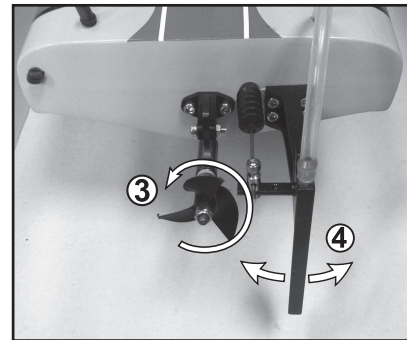

### Transmitter introduction

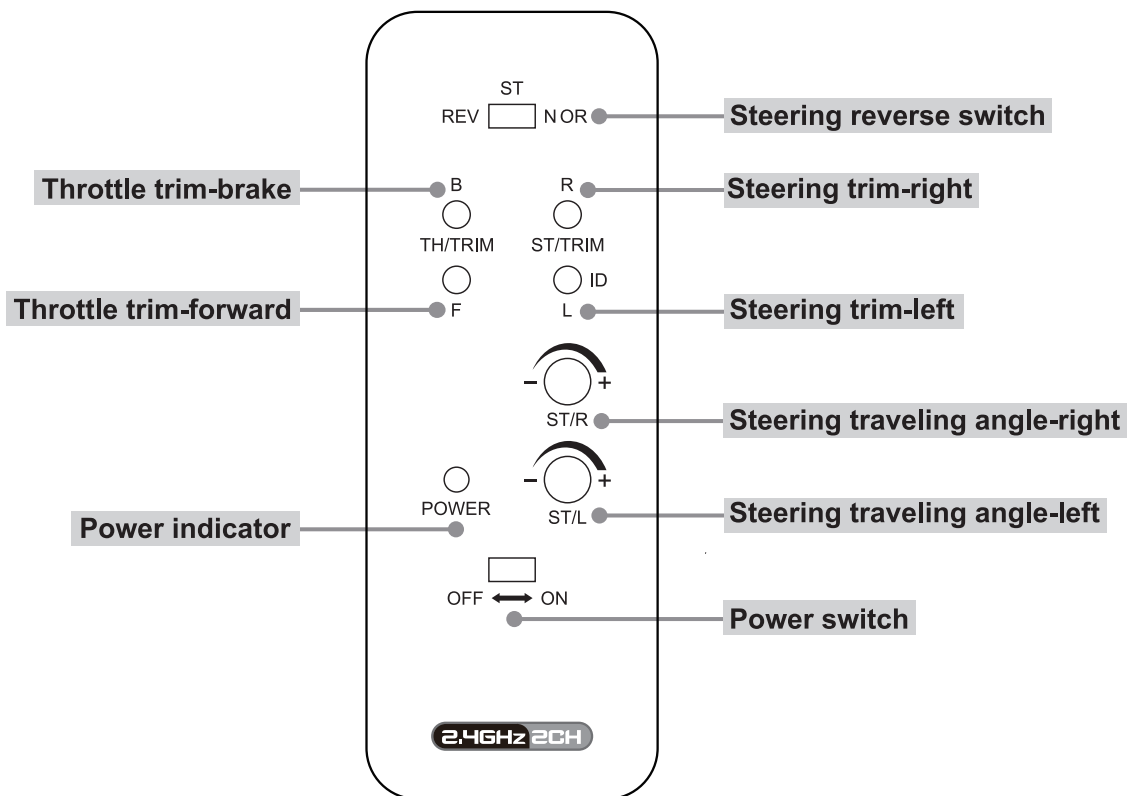

### EPA Adjustment

#### Function

Use this when performing left and right steering angle adjustments. End Point Adjustment (EPA) adjusting value range: 0%-100%

#### Setting

- Steering (right side) angle adjustment Rotate "ST/R" knob to the left end point means minimum value 0%, right end point means maximum value 100%.
- Steering (left side) angle adjustment Rotate "ST/L" knob to the left end point means minimum value 0%, right end point means maximum value 100%.

#### CAUTION:

When adjusting this function, make sure the direction is in agreement with the boat direction, you can adjust by the STEERING "REV-NOR" button.

#### Steering reverse switch

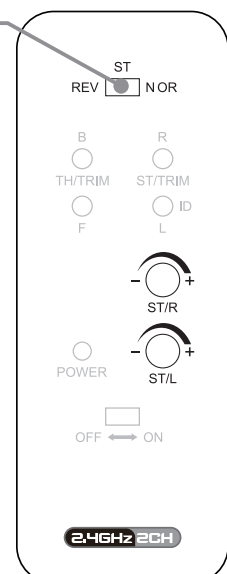
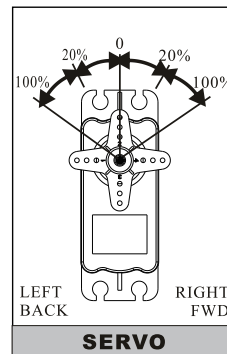



## Trim Adjustment

### Steering trim

Adjust "ST/TRIM" "R/L" so that rudder is centered prior to operation, you may adjust this control to make the boat run straight during operation.

### CAUTION:

When adjusting steering trim, make sure the direction is in agreement with the boat direction, you can adjust by the STEERING "REV-NOR" button.

### Throttle trim

Adjust "TH/TRIM" "B/F" to stop propeller from turning while the throttle trigger is in the neutral position.

Steering reverse switch

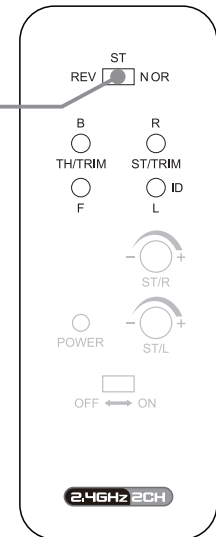

## Speed Control Specification

The Joysway brushed motor boat is assembled with 30A water cooled & water proof brushed ESC, please see belowing the specification:

LVP(low voltage protection) engaged when Lipo battery (per cell) drop down to 3.2 Voltage.

Operating Cells: 2S-3S Lipo or 7.2V NiMH

Current Rating: 25A-30A

Peak Current: 45A within 5 seconds

BEC Output: 1.5A/5V

## Lubricating The Drive Shaft

Lubricating the flexshaft is vital to the life of the drivetrain. The lubricant also acts as a water seal, keeping water from entering the hull through the stuffing box.

Lubricate the flexshaft, propeller shaft and all moving parts after every 2–3 hours of operation.

1. Before you disassemble flex shaft set, make sure ESC is out of connect with battery.
2. Use two 8mm spanner to loose motor coupler connection with flex shaft as shown.
3. Pull flex shaft w/prop shaft out from the rear shaft strut, dry the water on flex shaft and then lubricate the flexshaft with the water proof marine grease.

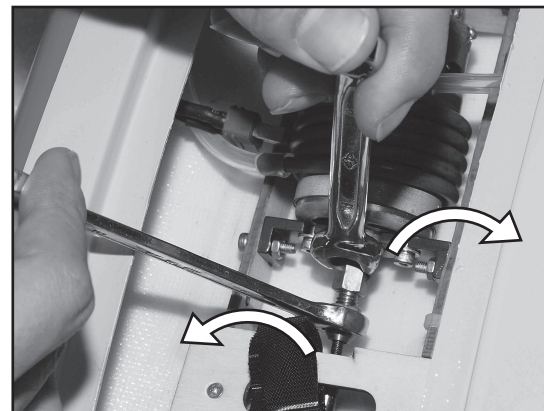

4. Before reinstall the flex shaft w/ prop shaft, make sure air dry the water inside the teflon tube , then reinstall the flexshaft w/ prop shaft in reverse order.

5. Before tighten the flex shaft with motor coupler by the two 8mm spanners, make sure nylon washer is 0.5mm gap with rear shaft strut. This is important.

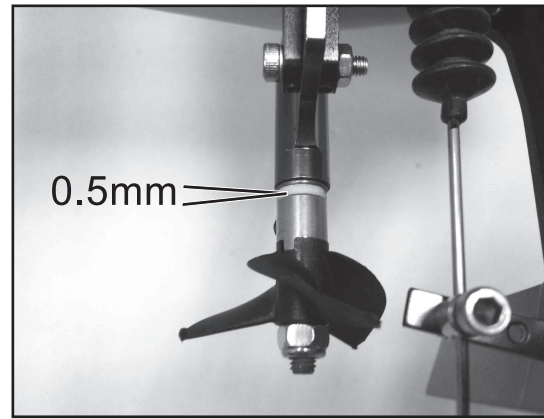

**NOTE:** Running the model boat in salt water could cause some parts to corrode. If you run the boat in salt water, rinse it thoroughly in fresh water after each use and lubricate the drive system.

## Spare part list

To order Joysway brushed motor boat spare parts, use the part numbers in the spare parts list that follows.

<b>PART NO.</b>	<b>DESCRIPTION</b>
932101	#9321 Hatch with decal stickers and painting
932103	Water cooling copper pipe for 550 motor
932104	Rear shaft strut set (W/O bearings) for #9321/9322
932106	P1.4XD37mm three blade nylon propeller (PK2)
932201	#9322 Hatch with decal stickers and painting
932202	Flex shaft set for #9322
860106	550 brushed motor
860107	30A Water cooled & water proof ESC w/ BEC
930502	Water proof gasket (PK2)
930505	Flex shaft set for #9305/9321
930507	Bearing set
930512	Velco strap set
930513	Silicone antenna cap(PK2)
930514	one meter silicone water cooling tube
930515	Water outlet
930516	Motor coupler set
93012	Rudder and Support Set
93017	water-proof rudder pushing rod tube(PK2)
610307	2S/3S Blance Charger with DC Adapter
880514	9g metal gear servo
820512	11.1V 1300mAh 35C LiPo pack



FCC WARNING: Changes or modifications not expressly approved by the party responsible for compliance could avoid the user's authority to operate the equipment.