

STEP 18: Fixing the Rudder

Using the side view and stern view on **Plan 4** and **picture 5** below as guides:

- Plank the rudder plywood part n.41 with 0.5x3 Walnut planks and sand the joints smooth.
- Fit a brass pintle and a brass ring to each side of the heel of the rudder to take the restraining chains. Fit a brass pintle with a brass ring into each side of the stern as shown in the stern view on **Plan 4**.
- Fit six black 'u'-shaped rudder shackles supplied to the keel as shown. Carefully cut a hole in the underside of the stern to take the top part of the rudder and slide the rudder into position. Mark the position of the tops of the rudder shackles on the rudder and fit six 'u'-shaped brackets to the rudder with the bottom edges lined up on these marks.
- Place the rudder in position and glue the six rudder pins into the shackles to hold the rudder onto the stern. Fit two restraining chains between the rudder pintles and the pintles on the stern.
- Fix the nameplate on the stern with two brass nails. Glue the two frame-less gunports on the underside of the stern. Abrade the back of the photo-etched gallery side panels n.42 and fix them on the supports with instant glue.

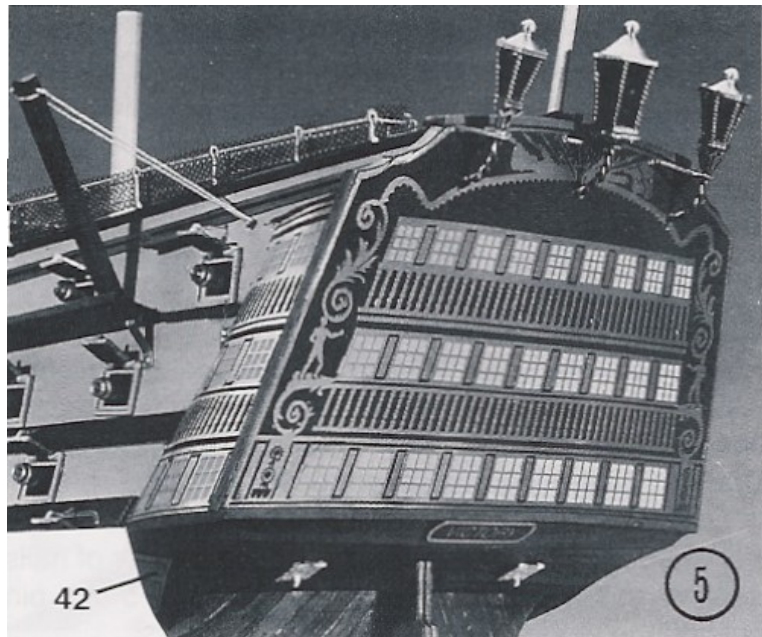

STEP 19: Adding the Beakhead Decorations

The bow transom behind the beakhead is fitted with arched panels and contains two 'roundhouse' toilets. The construction is shown here in **figure 17**. Bend the photo-etched panels 43L around the half-round supports n.44 and glue them to make the two roundhouses. Glue the photo-etched panel 39L on the bow transom with the two heads fitted either side. Fit the two roofs n.44 in place and glue a piece of 1x2 Walnut plank above the panel 39L.

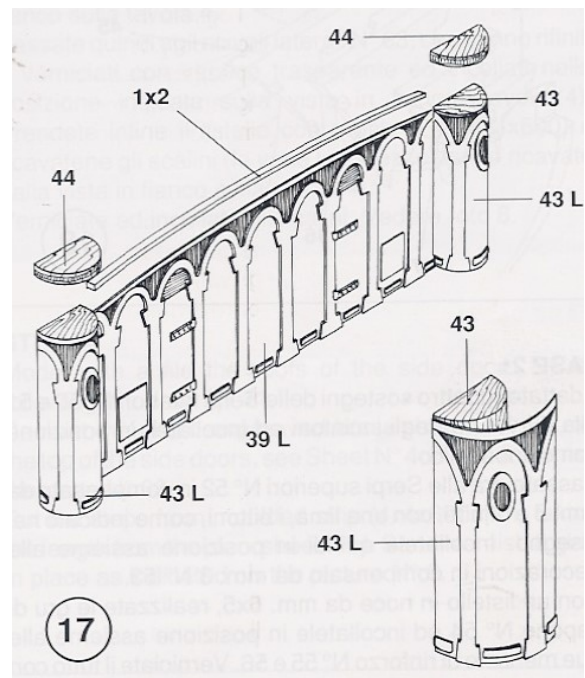

STEP 20: Adding the Herpe Deck

Fit the set of plywood frames n.45, n.46, n.47 and n.48 and the base n.49 on to the bow as shown below in **figure 18**, carefully checking the positioning. Plank the base with 0.5x3 Walnut planks, trimming the planks around the holes in the base.

Fit the photo-etched panel 49L onto the base with instant glue, and drill out the four large rectangular holes that take the bowsprit lashings.

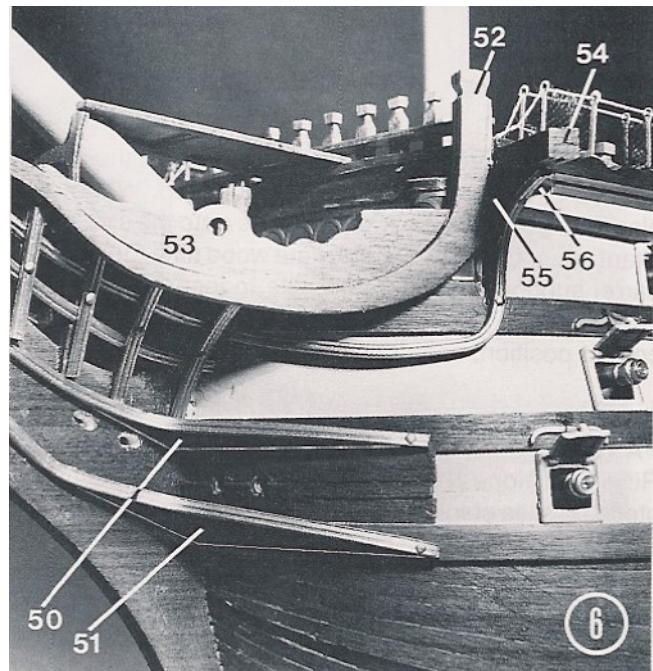
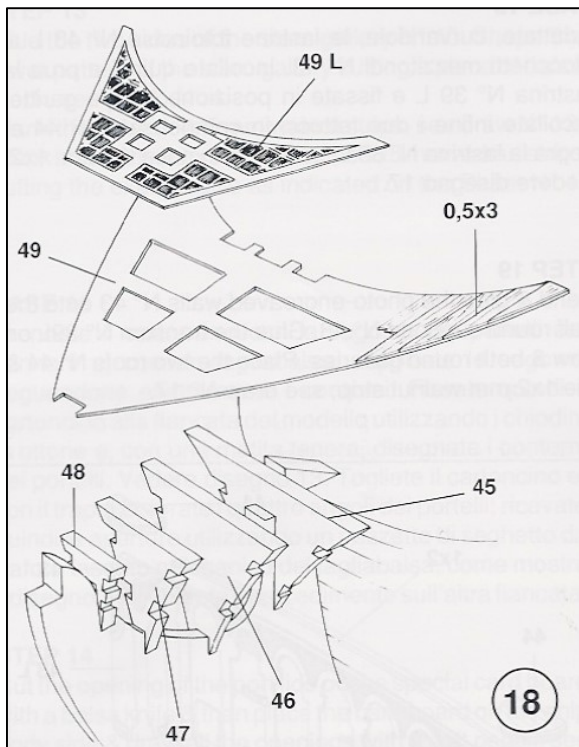

STEP 21: Adding the Herpe Supports

Using **picture 6** above as a guide, and referring to the front and side views on **Plan 4**:

- Fit the four plywood herpe supports n.50 n.51 on the bow with instant glue. Fit the upper herpes n.52 in place having shaped the knights with a file. Fit the plywood decorations n.53 in place.
- Varnish all the parts with sanding sealer. Make up and fit the 8 short and long brass mouldings onto the herpes supports each side of the bow using glue and brass nails.
- With a file, fettle the brass figurehead, clean the surface with thinners and paint the details with matt acrylic enamels following the Painting Plan at the end of this booklet. When dry, secure the figurehead in place using epoxy glue.

STEP 22: Fitting the Channels

Plank channels n. 57, 58, 59, 60 and 61 on both sides with 0.5x3 Walnut strips and sand smooth. Paint the edges with walnut watercolour stain. Varnish over when fully dry.

Channels n.57, 58 and 59 are fitted along the upper gunwale planks, n.60 and 61 are fitted to the hull planking. Using the overhead view on **Plan 4**, mark the positions of the channels on the ship. Shape the inside edge of each channel to fit snugly against the curvature of the hull and to sit horizontally. Using the side view on Plan 6 as a guide, file 2mm wide by 1mm deep slots for the deadeyes in the outside edge of the channels.

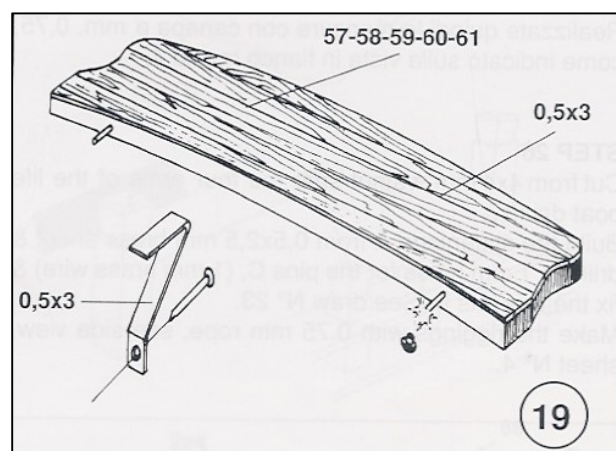

Drill two $\varnothing 0.7$ holes in each channel edge, glue in a pair of brass nails, and cut off the nail heads to leave 5 mm long pins as tenons. Mark and drill the hull for the tenons and fix the channels to the hull with instant glue. Make and fit brass support brackets from 0.5x3 brass sheet as shown in **figure 19** and in **Plan 4**, secured with instant glue and brass nails. Fit a 2x2 Walnut restraining plank along the outside edge of each channel (see **picture 7** below). Radius the ends and varnish over.

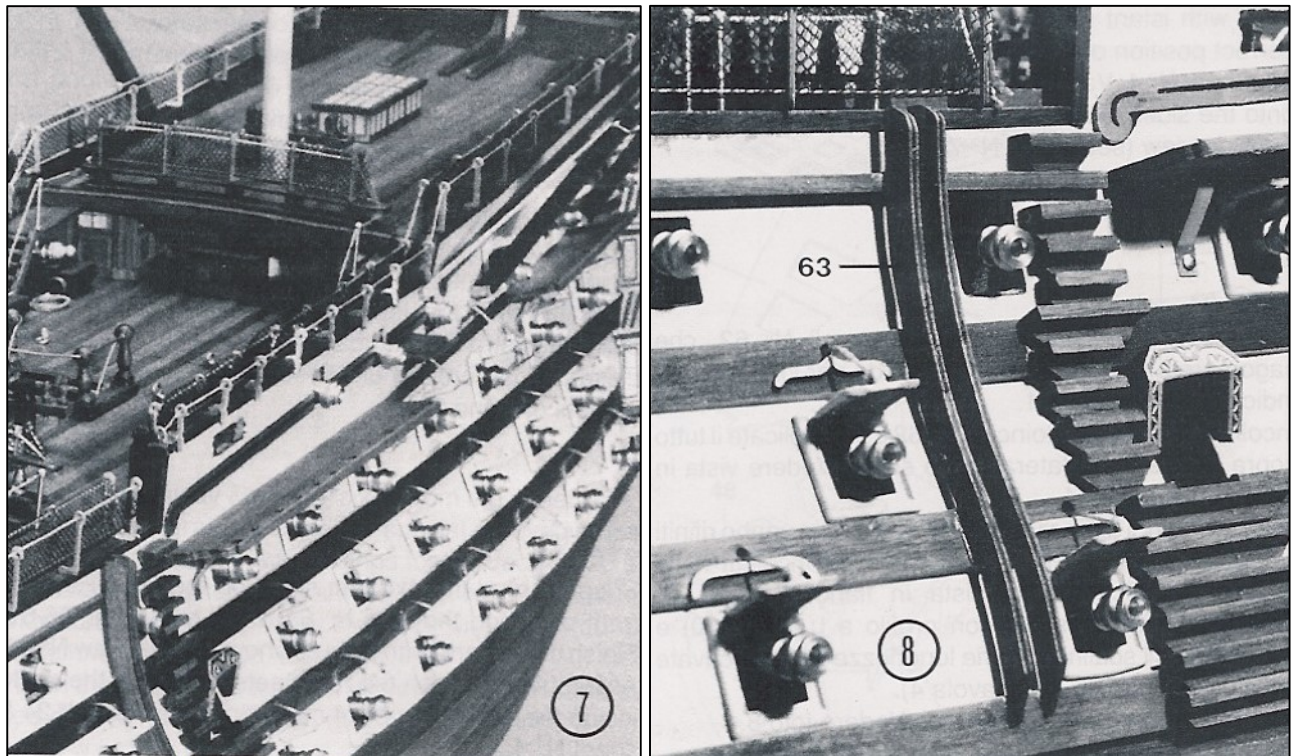

STEP 23: Fitting the Hull Decorations

Using **figure 20** and the side view on **Plan 4** as guides, fix the six photo-etched brass hull decoration strips to the gunwales in the positions shown. Fit the brass gunport drip-rails in place with instant glue.

STEP 24: Fitting the Side Canopies and the 'Sea Gangway'

Using the side view on **Plan 4** and **picture 8** above as guides:

- Shape the Walnut side door canopy blocks Item 62 (provided in the flag pack), glue them to the hull sides and varnish over. Bend and fix the two canopy decorations 62L in place on the canopies with instant glue. See **figure 21** opposite.
- Varnish the hauling-slides n.63 and fit a pair to each side of the hull as shown in diagram 8 above.
- Cut the rungs for the sea gangway (the ladders on the outsides of the hull) from 4x4x600 'L-shaped' Walnut plank as shown in **picture 8** above, fix them to each side of the hull with instant glue, and varnish over.

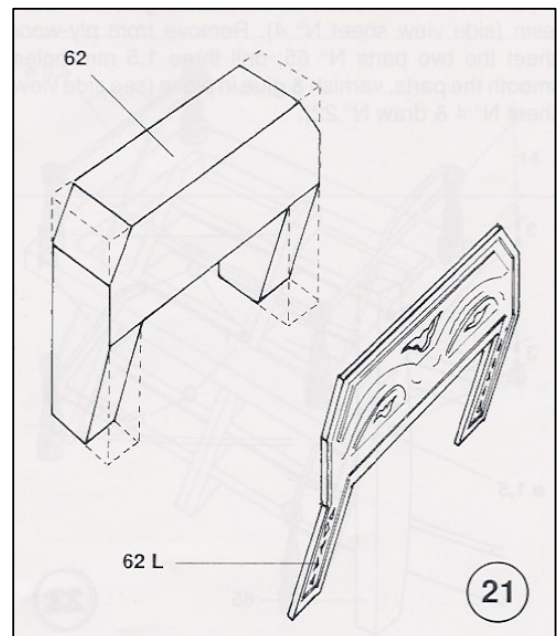

STEP 25: Chocks and Rigging Beams

Using the side view on **Plan 4** and **figure 22** below as guides:

- Cut the two chocks item 64 from the photo-etched brass sheet, drill two $\varnothing 1$ holes in the hull stern-sides and fit the chocks in place with instant glue.
- Drill a third $\varnothing 1.5$ hole through the top of the rigging beams ply-wood parts n.65, sand smooth, varnish over and fix in place on the hull amid-ship.

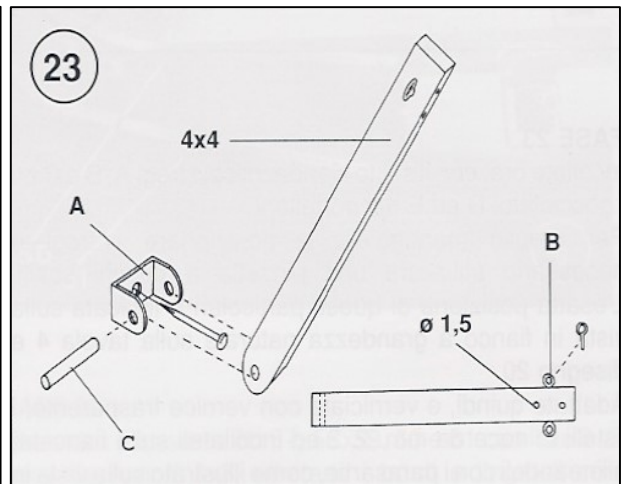
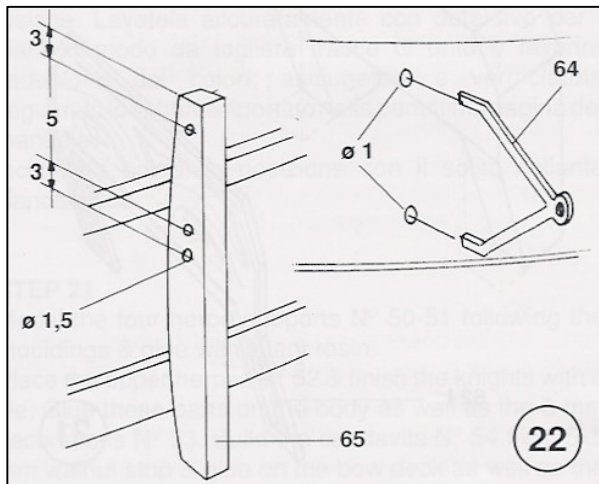

STEP 26: Fitting the Stern Lifeboat Davits

Using the side view on **Plan 4**, the colour illustration on the box and **figure 23** above as guides, Construct the four davits as follows:

- Make each arm of the four lifeboat davits from 4x4 Walnut plank, drill a $\varnothing 1$ hole for the pivot pin, drill a $\varnothing 1$ hole and fit two brass eyelets item B in each side of the free end.
- Make the brackets item A from 0.5x2.5 brass strip; drill $\varnothing 1$ holes for the fixing nail and for the pivot pin item C (made from $\varnothing 1$ brass wire). Fix each bracket to the hull with a brass nail and instant glue, and fit the arms in place, securing the pivot pins with instant glue.23.
- Rig the davits with $\varnothing 0.75$ rope in the raised position as shown in the side view on **Plan 4**.

STEP 27: Fitting the Bitts

Make and fit three 4x4 Walnut banisters on the forecastle (bow) deck and fit 2x4 railings on top as shown in figure 24 opposite. Finish the tops of the bitts n.68 with a file as shown in **figure 24** and fit the bitts into the pairs of guide rails n.66 (sides) and n.67 (front). Assemble the three sets of bitts on the deck, inside the banisters as shown. Varnish over.

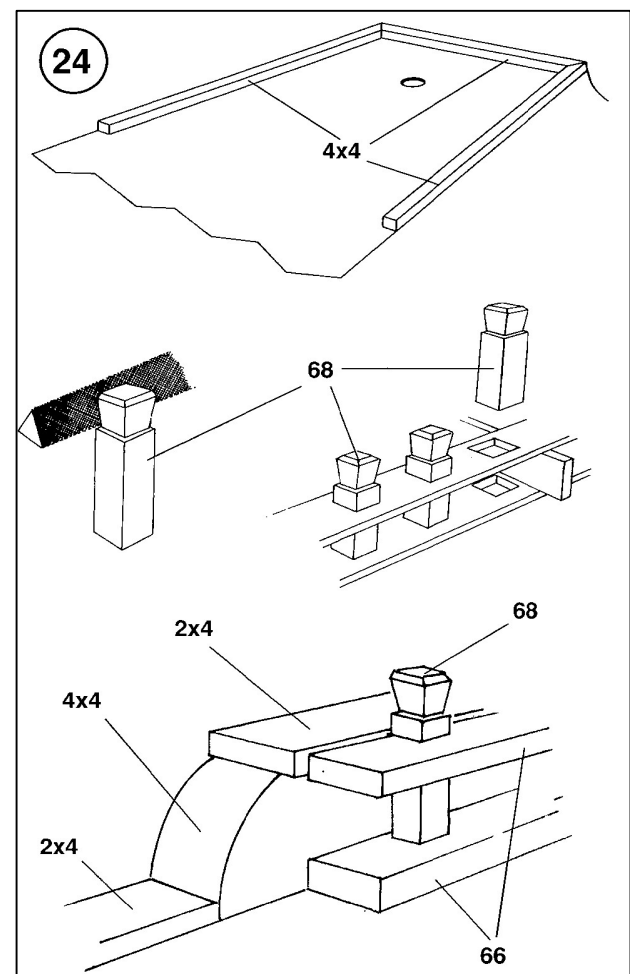

STEP 28: Gratings and Hatchways

Take the hatchway and grating sizes from the overhead view on **Plan 4**.

Assemble the gratings using the special grooved strips and drops of instant glue. Frame them with 3x3 Walnut plank for the gratings on deck n.32, and with 2x2 Walnut plank for those on deck n.33.

Curve the front and rear sides with a half-round file following the sheer of the deck as shown in **figure 25** opposite.

Varnish over and fit to the deck with instant glue.

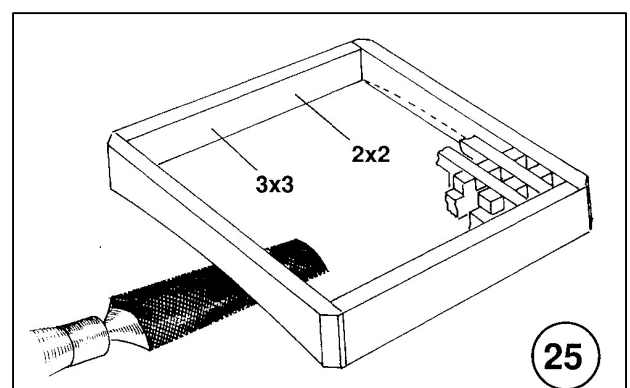

Trim the three hatchways with 2x2 Walnut plank. Build the ladders from the pre-cut sidepieces and treads made from 1x4 Walnut plank, cut to fit the hatchway apertures. Varnish over and glue in place. For the quarterdeck hatchway, make the railings from 0.5 brass wire and fit to the wooden posts supplied as shown in **figures 26** and **27** below. Varnish over before fitting them to the deck.

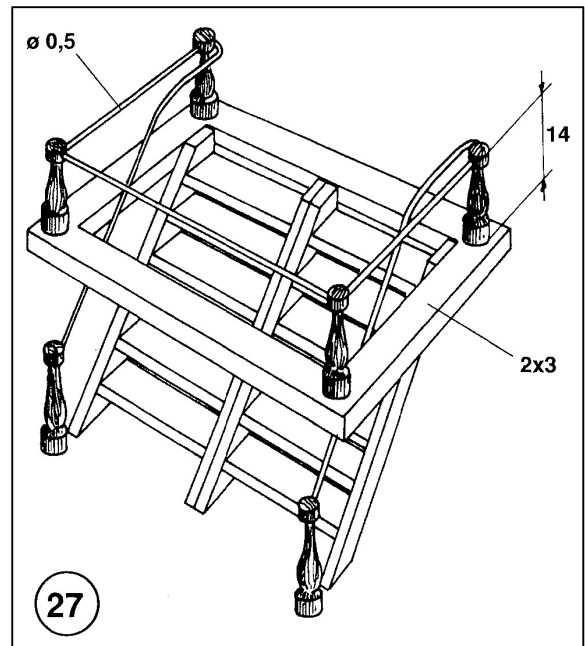
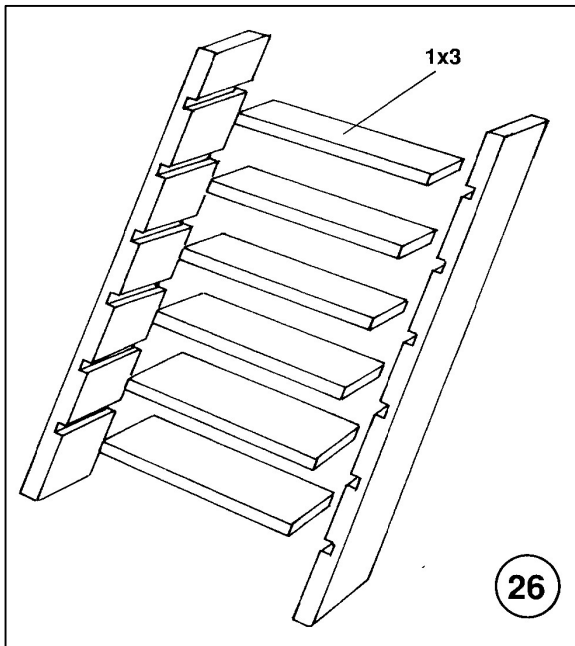

STEP 29: Carronades and Cannons

Make the two Carronade carriages by planking the bases n.69 with walnut strips as shown in **figure 28** opposite. Place the brass barrels on pivots made from $\varnothing 0.5$ brass wire and secure with instant glue. Fit rigging eyelets and rings to the base and fix the bases on the forecastle deck with instant glue.

Figure 29 shows how to build the carriages for the ten cannons on the upper gundeck and for the six cannons on the quarterdeck, using plywood parts n.70 and n.71 and the wheel-and-axle units supplied.

Figure 30 shows a finished gun position fitted with 1x3 Walnut beams, eyelets and $\varnothing 0.5$ rope rigging.

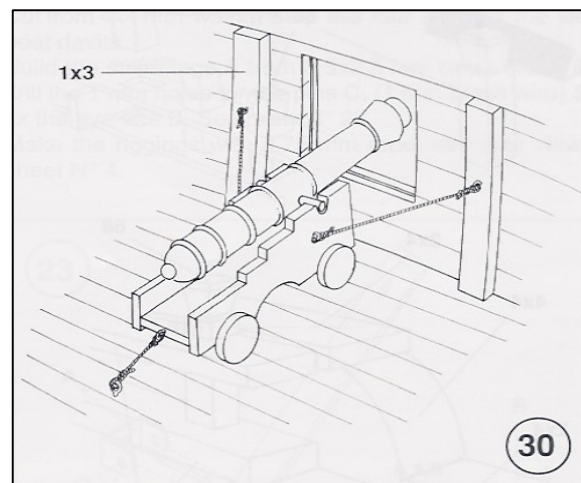
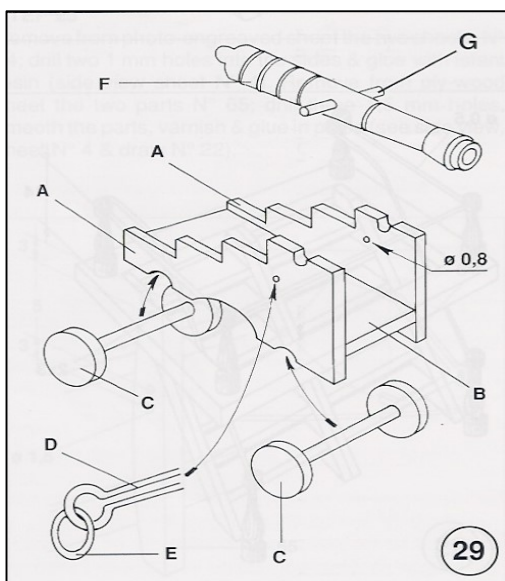
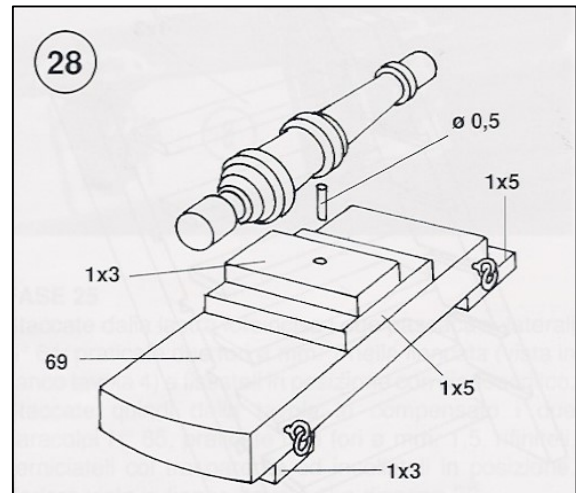

STEP 30: Stanchions and Deck-ladders

The following items are assembled in and around the aperture (waist) above the lower gundeck see **picture 9** below. Fit a transom crossbeam made from 4x4 Walnut supported on two cylindrical pillars under each end of the waist. Trim the front and rear frames n.72 to fit the waist and then drill and fix the seven eyelets and brass rings on each part. Varnish over and fix in place on the transoms as shown on the overhead and side view on **Plan 4**. Trial-fit the six crossbeams n.74 into the two pieces n.73 and adjust to fit the width of the waist. Mark the positions of the crossbeam pillars and fit the pillars in place on the lower gundeck. Fit the crossbeam assembly in place across the waist. Varnish over.

Make and assemble the four deck ladders in the waist. Mark the stanchion positions on the decks with a pencil, drill $\varnothing 1$ holes and fix the thirty 12 mm-long brass stanchions in place with instant glue, ensuring that the handrail holes all line up along the deck. Thread $\varnothing 0.75$ rope through the stanchions to make handrails and secure the ends with a drop of instant glue.

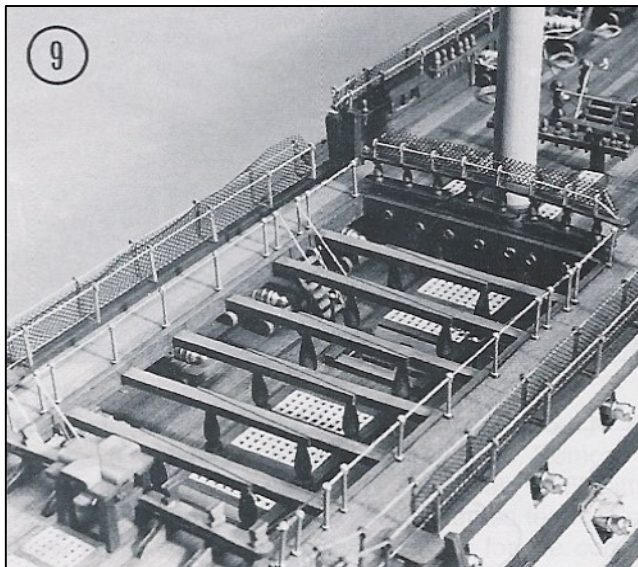

STEP 31: Banister Hammock Netting

Using the side and overhead views on **Plan 4**, and **figure 31** opposite as guides, make 13 accurate cubes from 4x4 walnut strip and build the main and mizzen banisters using plywood parts n.75 and n.76 as shown. Drill $\varnothing 1$ holes in the upper strips and insert the 'U-shaped' stanchions cut from the photo-etched brass plate secured with a drop of instant glue. Varnish the wood and brass items. Thread lengths of $\varnothing 0.5$ rope through the stanchions, securing the ends with instant glue. Using a low-temperature steam iron, flatten the hammock netting, before cutting it to size. Measure the netting pieces and cut them from the sheet. U-fold the net and iron the corners to help the nets sit down on the bases before fixing them in place with instant glue.

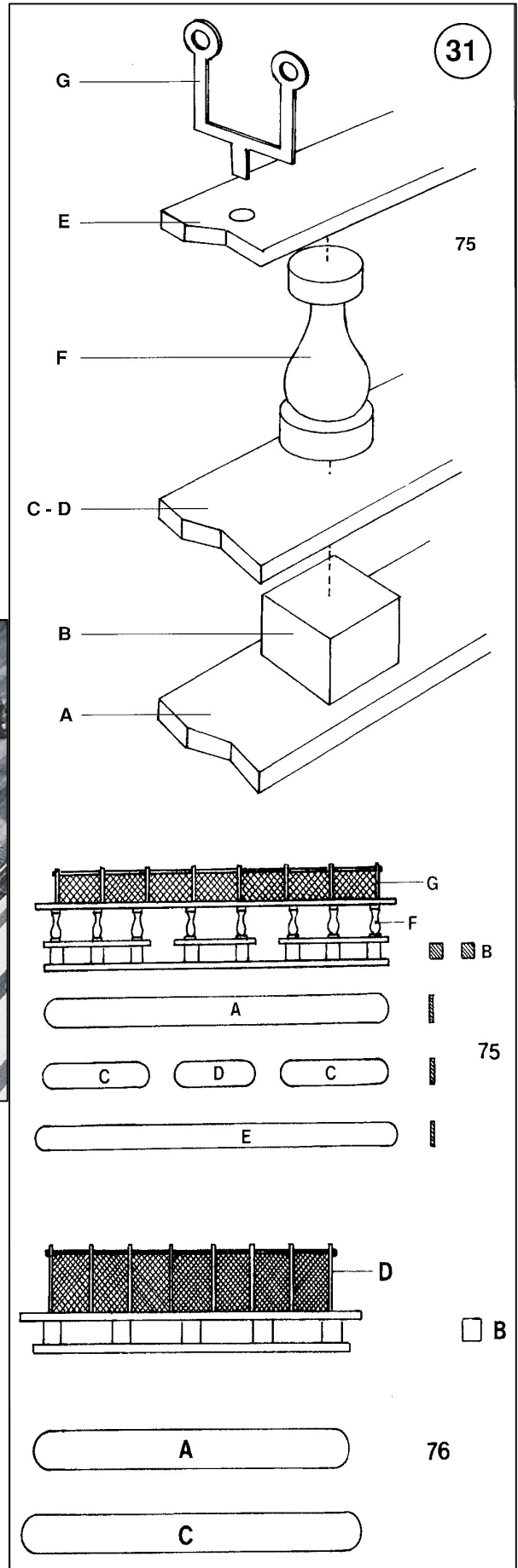

STEP 32: Belfry and Galley Funnel

Figure 32 below shows how to build the belfry from parts 77A, B, C and D, and how to shape the roof. Fix the bell with the pins G: $\varnothing 0.5$ brass wire and a small brass nail.

Picture 10 opposite shows the construction of the two fore fife rails, made from plywood parts N.78A and n.78B.

Figure 33 shows how to make the galley funnel from $\varnothing 5$ dowel. Paint it matt black and glue it on to a base made from 2x10x10 Walnut plank. Fix it on deck between the gratings as shown in **diagram 10** opposite, pointing to the stern.

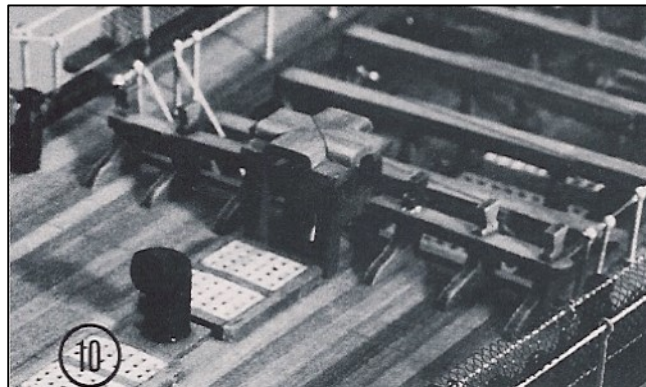

STEP 33: Stern Brackets

Picture 11 below shows the assembly of the stern boxes and brackets (parts n.80A, C, D and F), and the flagstaff support (parts n.80B and 80C) on the poop deck.

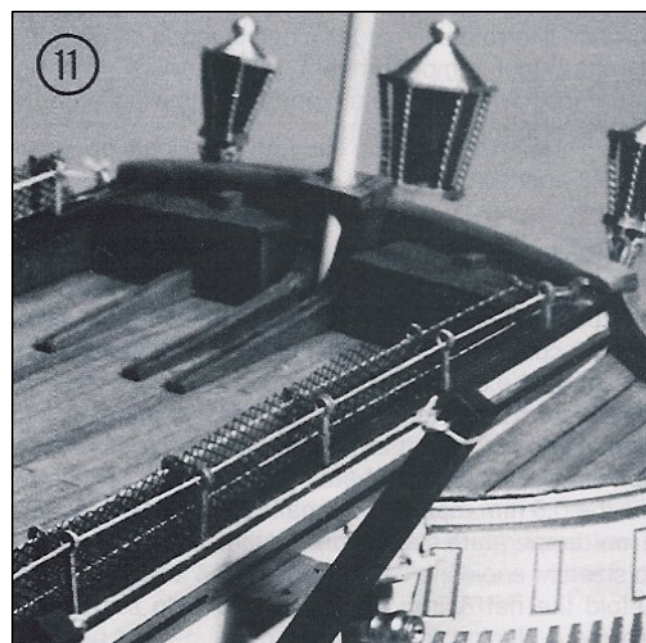
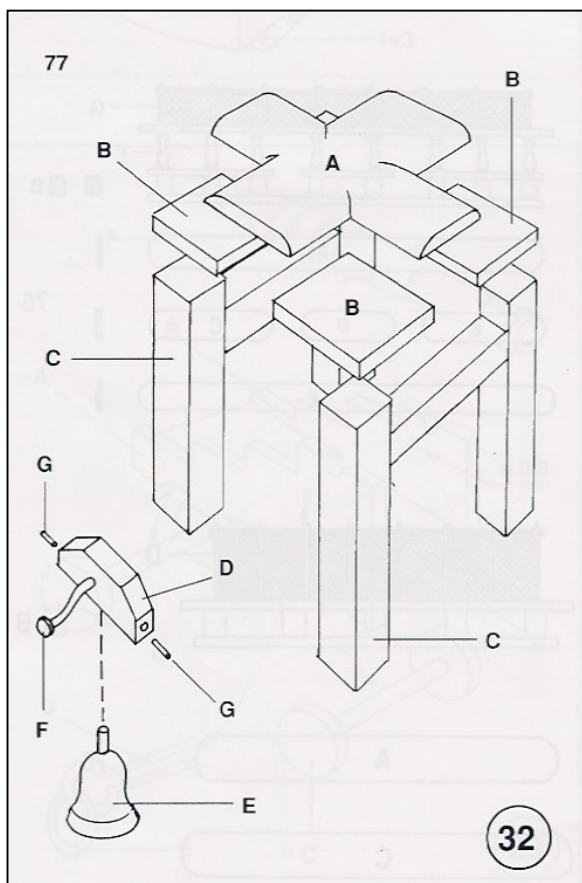
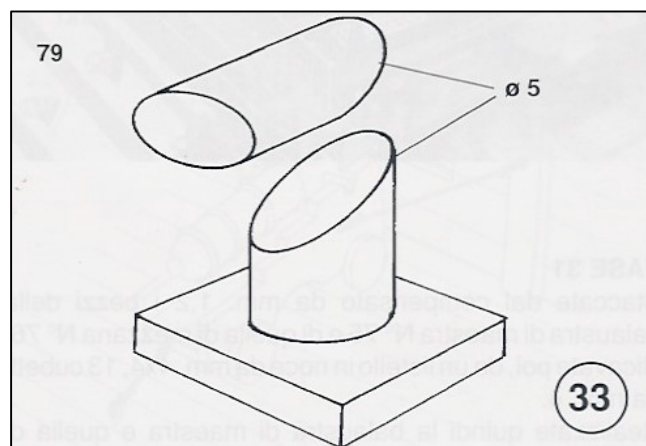

STEP 34: Fife-Rails and Bitts

Figure 34 below shows how to make the fife rails. Parts n. 81A and B make the mizzen fife-rail; parts, n.82A and B make the main fife rail; parts n.83 make the two fore fife-rails. Varnish over. Drill the bases and fit pieces of $\varnothing 1$ brass wire as tenons. Drill the deck and fix the fife rails in place with instant glue. Shape the bow bitts n.84 and the main bitts n.85 with a file. Drill the bases and fit pieces of $\varnothing 1$ brass wire as tenons. Drill the deck and fix the bitts in place with instant glue.

See the overhead view on **Plan 4** for the correct positioning of the bitts and fife rails.

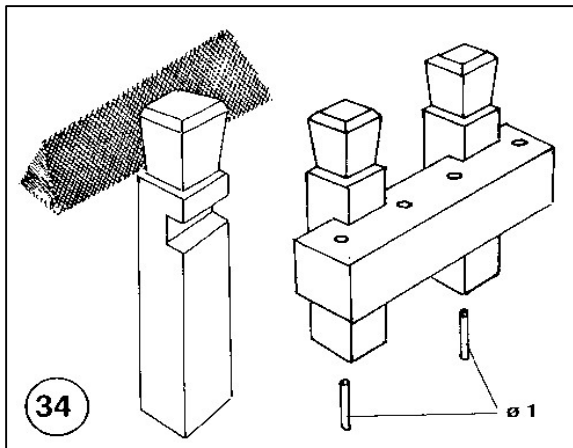

STEP 35: Stern Galleries

Picture 12 above shows the stern galleries (access platforms) are assembled from parts n.86. Make up the two ladders and glue the galleries and ladders in place. Drill $\varnothing 1$ holes and fix the stanchions in place with instant glue. Thread a length of $\varnothing 0.75$ rope through the stanchion to make the handrail, securing the knots with instant glue.

STEP 36: Skylight

Figure 35 shows how to build the skylight from the wooden block item 87 (7x13x30), with the previously painted photo-etched brass parts 87L fitted on the four ends and top. Frame the top and bottom edges with 1x1 Walnut plank. Varnish and place the skylight on the poop deck behind the mizzenmast.

Figure 36: Assemble the compass housing from parts n.88A and 88B. Make the three panels from 0.5x3 Walnut plank. Sand and varnish over. Fit the assembly on the quarterdeck in front of the officer's cabins. See the overhead view on **Plan 4**.

STEP 37: Bulwark Hammock Netting

Remove all the 'U-shaped' bulwark stanchions A to I from the photo-etched brass plate using the illustration of the plate in **figure 37** on **Plan 4** as a guide. Draw each stanchion fixing point on the railings with a pencil, drill $\varnothing 1$ holes, and fix the stanchions with instant glue. Thread and knot lengths of $\varnothing 0.75$ rope through the stanchions and fit the netting as described in step 31.

STEP 38: Lanterns and Parrels

Assemble the four lanterns item 89 as shown in **figure 38** below, and secure the parts with drops of instant glue. Bend the twisted support stanchions at right angles with round pliers so that they will slide into holes drilled on the stern transom as shown on the stern view on **Plan 4**. Fit the photo-etched lantern brackets 89L in place by drilling the necessary holes in the stern and securing the parts in place with instant glue.

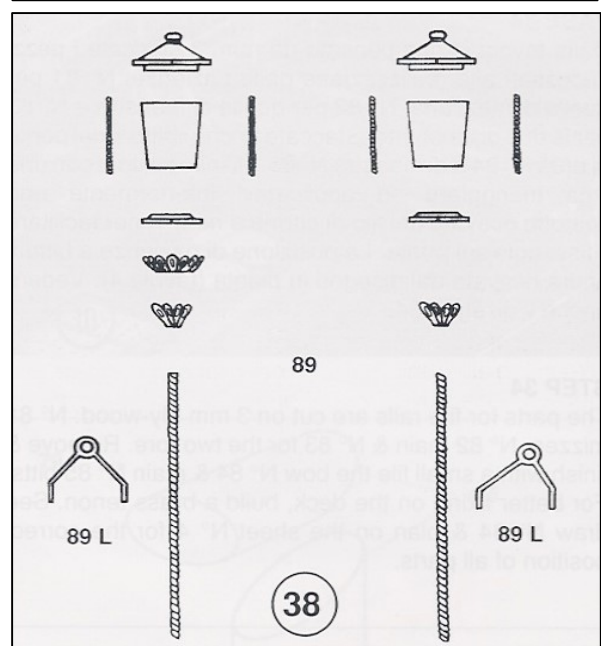
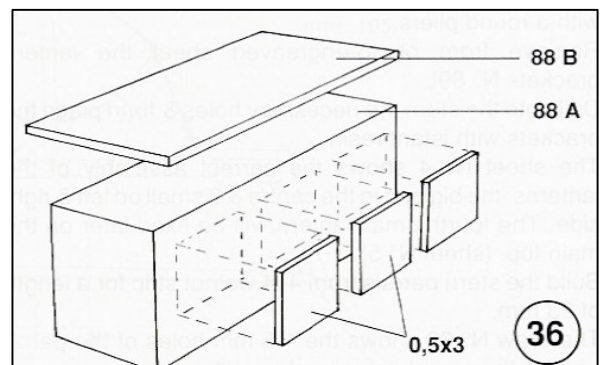
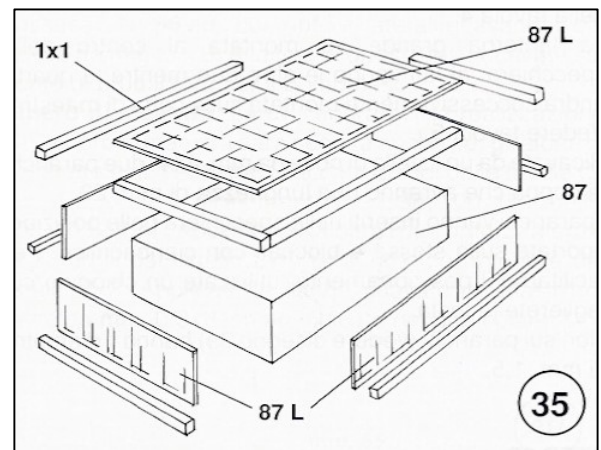
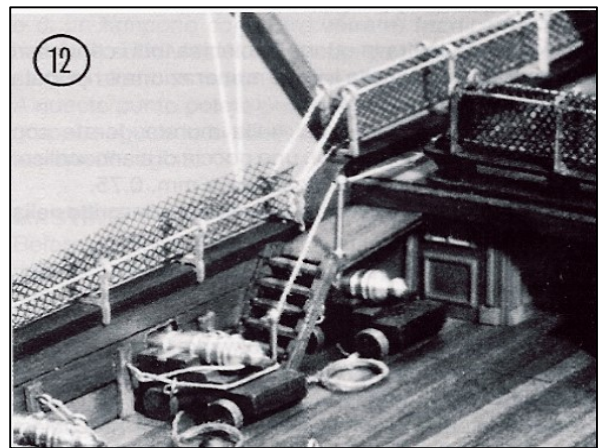

The stern view on **Plan 4** shows the correct assembly of the lanterns: the large lantern in the centre with two small lanterns to the left and to the right. The third small lantern will be fixed later on the main top (Plan N° 5).

Build the two stern parrels from 4x4 walnut plank - length 23 mm plus a tenon of 3 mm. Drill $\varnothing 1.5$ holes in the parrel head as shown in **figure 39** opposite. Drill the back of the stern transom for the parrels' tenons, and glue the parrels in place ensuring that the parrels are parallel and horizontal, and the holes are facing upwards. Varnish over.

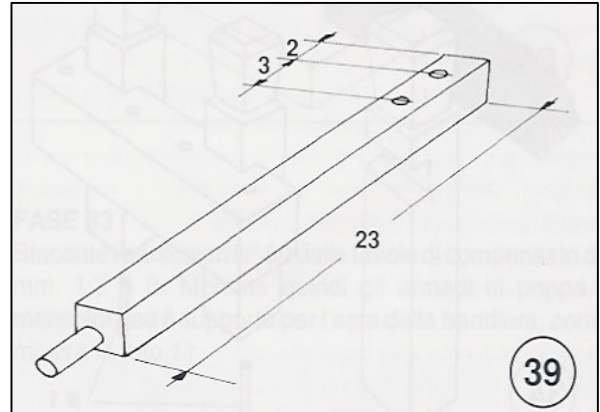

STEP 39: Belaying Pins and Lifeboat Supports

Drill $\varnothing 1.3$ holes in the belaying-pin racks n.91A and B as shown on the overhead view on **Plan 4**, fit a belaying pin in each hole, varnish and fit along the parapets as shown. Drill and fit the carronade ball racks n.91C in the corners of the forecastle deck.

Fit the lifeboat supports n.90A, B and C onto the waist cross beams n.74. Drill four $\varnothing 1$ holes in the lower gundeck and fit brass eyelets and brass ring to each for the lifeboat rigging as shown in the overhead view on **Plan 4**.

The six lifeboats are not supplied in the kit, leaving the optional choice to the modeler. Optional sets of wooden body or plastic lifeboats (easier to assemble & finish) are available from Mantua Model. Ask your supplier for details.

Figure 40 shows the assembly of the lifeboats on deck, placed there when all rigging is completed.

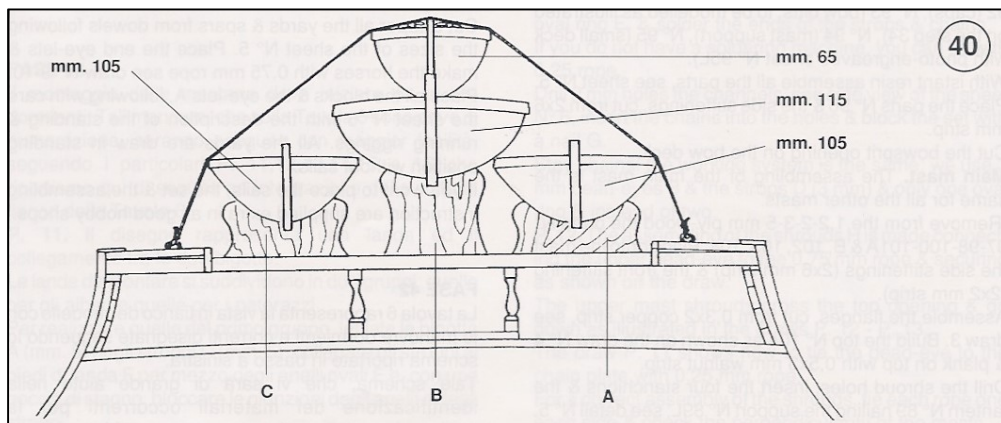

MASTING

Taking the measurements from the notes on **Plan number 5**, cut and shape the dowels to make the various masts and spars for the *Victory*. We advise you to proceed carefully and to "measure twice and cut once" to avoid errors and wastage. The plan shows the masts and spars full size and identifies the cutting and tapering dimensions: **L** = the finished length; \varnothing **Max** = the maximum dimension; \varnothing **Min** = the minimum diameter at the ends.

Unless shown otherwise, taper the dowels towards one end only. Where indicated, taper the dowels using either i) a hand plane and sandpaper, or ii) an electric drill and sandpaper, or preferably, iii) an electric lathe (such as Mantua Model **Art. 8160**). For the yards, start the tapering 75mm from the ends, leaving the centre section unaltered. Finish the masts and spars with fine grit sandpaper and varnish with two coats of matt varnish, sanding lightly between coats.

Temporarily label the masts and spars with masking tape until assembled.