

# F-16 ARF

## Assembly Manual



### Specifications

Wingspan:	28 in (709mm)
Length:	35.5 in (900mm)
Wing Area:	195 sq in (12.6 sq dm)
Weight w/o Battery:	18–20 oz (510–567 g)
Weight w/Battery:	23.5–25.5 oz (667–723 g)

**LOCKHEED MARTIN**

LOCKHEED MARTIN, F-16, associated emblems and logos, and body designs of vehicles are either registered trademarks or trademarks of Lockheed Martin Corporation in the USA and/or other jurisdictions, used under license by Horizon Hobby, Inc.

## Table of Contents

Introduction .....	2
Using the Manual.....	2
Contents of Kit/Parts Layout.....	2
Recommended Radio Equipment .....	3
Optional Accessories.....	3
Required Tools and Adhesives .....	3
Required Speed Control and Battery.....	3
Notes Regarding Servos and ESC .....	3
Note on Lithium Polymer Batteries .....	3
Warning.....	3
Wing and Stabilizer Installation .....	4
Elevator and Aileron Servo Installation .....	6
Landing Gear Installation.....	9
Speed Control and Receiver Installation .....	13
Vertical and Ventral Fin Installation.....	15
Motor Battery Installation .....	16
Missile Installation (Optional).....	17
Removing Fan and Motor for Servicing or Replacement .....	17
Radio Programming .....	18
Control Throws.....	19
Center of Gravity .....	20
Preflight.....	20
Range Test Your Radio .....	20
Flying Your F-16 .....	21
Safety, Precautions, and Warnings .....	21
Warranty Information.....	21
Instructions for Disposal of WEEE by Users in the European Union.....	22
2008 Official Academy of Model Aeronautics Safety Code .....	23

## Introduction

The F-16 Fighting Falcon was originally designed in 1971 to be a multi-role fighter in both air-to-air combat and air-to-surface attacks. Today the F-16 is known for its amazing maneuverability, precision strike and attack capabilities and speed. The F-16's versatility allows it to be equipped with a variety of weapons, including missiles or bombs. The Fighting Falcon is still in use today and is currently serving many countries. The USAF uses F-16s in their Thunderbird demonstrations.

E-flite's F-16 400 DF (ducted fan) is designed to replicate the full-scale F-16 as a performance sport scale model. Constructed of lightweight, durable injection molded foam, the F-16 is beautifully finished with a highly visible USAF Thunderbirds trim scheme. The F-16 400 DF also includes molded panel lines and custom applied decals for added scale appearance. It is highly prefabricated with molded servo pockets, prehinged flight surfaces, a magnetic battery hatch and the included and installed motor and fan unit to get you in the air faster.

The F-16 is capable of smooth, aerobatic maneuvers sure to please any crowd and the USAF Thunderbirds trim scheme will make all of your friends jealous. The E-flite F-16 400 DF will offer the ambitious sport scale modeler just the thrill he's been looking for.

## Using the Manual

This manual is divided into sections to help make assembly easier to understand, and to provide breaks between each major section. In addition, check boxes have been placed next to each step to keep track of its completion. Steps with a single circle (○) are performed once, while steps with two circles (○○) indicate that the step will require repeating, such as for a right or left wing panel, two servos, etc.

Remember to take your time and follow the directions.

## Contents of Kit/Parts Layout

### Replacement Parts

EFL7076	Fan Unit w/Motor
EFL7077	Canopy/Hatch
EFL7078	Stabilizer Set
EFL7079	Exhaust Nozzle and Nose Cone
EFL7080	Missiles and Launch Rails
EFL7081	Landing Gear Set w/Hardware
EFL7082	Gear Doors and Ventral Fins
EFL7083	Pushrod Kit



*The Spektrum trademark is used with permission  
of Bachmann Industries, Inc.*

*E-flite F-16 ARF Assembly Manual*

## Recommended Radio Equipment

You will need a minimum 4-channel transmitter, receiver, and four or five servos (if using nose gear steering). You can choose to purchase a complete radio system. If you are using an existing transmitter, just purchase the other required equipment separately. We recommend the crystal-free, interference-free Spektrum™ DX6i 2.4GHz DSM® 6-channel system. If using your own transmitter, we recommend the E-flite S60 Super Sub-Micro servos .

If you own the Spektrum DX6i radio, just add the AR6200 DSM2™ 6-channel receiver and four or five (nose gear steering) E-flite S60 Super Sub-Micro servos.

### Complete Radio System

SPM6600 DX6i DSM2 6CH system

### Or Purchase Separately

SPMAR6200 AR6200 DSM2 6-Channel Full-Range Receiver (for DX6i or DX7)

### And

EFLRS60 S60 Super Sub-Micro Servo (4, 5 if using nose gear steering)  
EFLREX3L 3-inch Extension, Lightweight (2)  
EFLREX9L 9-inch Extension, Lightweight (2)

**Note:** If you are not using a computer radio, you will be required to purchase the following items:

EFLRYH3 3-inch Y-Harness, Lightweight  
EXRA320 Y-Harness 6-inch/Reverser Standard

## Optional Accessories

EFLA110 Power Meter  
EFLC3005 Celetra™ 1- to 3-Cell Li-Po Charger  
EFLC505 Intelligent 1- to 5-Cell Balancing Charger

## Required Tools and Adhesives

### Tools & Equipment

Mixing sticks Paper towels  
Rubbing alcohol Mixing cups  
Dental floss Hobby knife (#11 blade)  
Pin drill Drill bit: 5/64-inch (2mm)  
Sandpaper Epoxy brushes  
Phillips screwdriver: #00, #1

### Adhesives

Threadlock 6-Minute Epoxy (HAN8000)  
Medium CA (optional for missile installation)

## Required Speed Control and Battery

EFLA1025 25-Amp Pro Brushless ESC  
THP21003SPL 2100mAh 3-Cell 11.1V LiPo, 16GA

## Notes Regarding Servos and ESC

**WARNING:** Use of servos other than those we suggest may overload the BEC of the recommended Electronic Speed Control (ESC). Please use only the servos listed when utilizing the recommended ESC's BEC, or the use of a separate BEC (like the UBEC) or receiver battery pack when using other servos.

**We recommend the use of our E-flite 25-Amp Pro Brushless ESC (EFLA1025). You will notice that the manual for the ESC recommends the use of only 4 servos while using the BEC. The F-16 uses 5 servos with the optional nose gear steering. We have tested this setup and due to the low usage and current draw of this nose gear steering servo, the ESC is capable of operating with the BEC under this condition.**

## Note on Lithium Polymer Batteries



Lithium Polymer batteries are significantly more volatile than alkaline or Ni-Cd/Ni-MH batteries used in RC applications. All manufacturer's instructions and warnings must be followed closely. Mishandling of Li-Po batteries can result in fire. Always follow the manufacturer's instructions when disposing of Lithium Polymer batteries.

## Warning

An RC aircraft is not a toy! If misused, it can cause serious bodily harm and damage to property. Fly only in open areas, preferably at AMA (Academy of Model Aeronautics) approved flying sites, following all instructions included with your radio.

Keep loose items that can get entangled in the propeller away from the prop, including loose clothing, or other objects such as pencils and screwdrivers. Especially keep your hands away from the propeller.

During the course of building your F-16 we suggest that you use a soft base for the building surface. Such things as a foam stand, large piece of bedding foam or a thick bath towel will work well and help protect the model from damage during assembly.

## Wing and Stabilizer Installation

### Required Parts

Fuselage                      Wing panel (right and left)  
Stabilizer (right and left)  
2mm x 12mm self-tapping screw (4)

### Required Tools and Adhesives

6-minute epoxy              Mixing cup  
Mixing stick                 Epoxy brush  
Paper towel                 Rubbing alcohol  
Sandpaper                 Phillips screwdriver: #1

### ***Etips***

During the manufacturing process it is possible that a slight amount of glue may seep in to the inner side of the wing joiner socket. If you are having trouble with the wing fitting flush against the fuselage check the inside of the joiner socket. If some glue has seeped into the socket use a small hand file to remove it.

- 1. Test fit the wing panel to the fuselage by sliding the joiners into the joiner sockets of the fuselage. The panel must fit tightly against fuselage when installed. If it does not, you may be required to sand the end of the joiner slightly so the wing will have a flush fit against the fuselage.

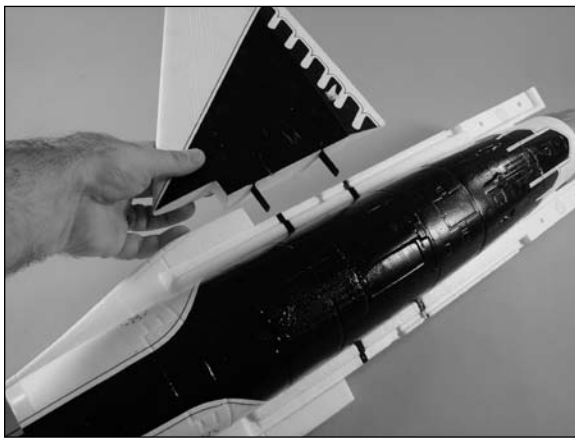

**Important:** You will be required to quickly perform the next few steps before the epoxy begins to cure. Read through the following steps to prepare yourself for the gluing process.

- 2. After checking the fit, remove the wing panel from the fuselage. Prepare 1/4-ounce (10cc) of 6-minute epoxy and brush a very light coating of epoxy on the wing and fuselage where they contact each other. Also brush some glue into the inside of the joiner socket.

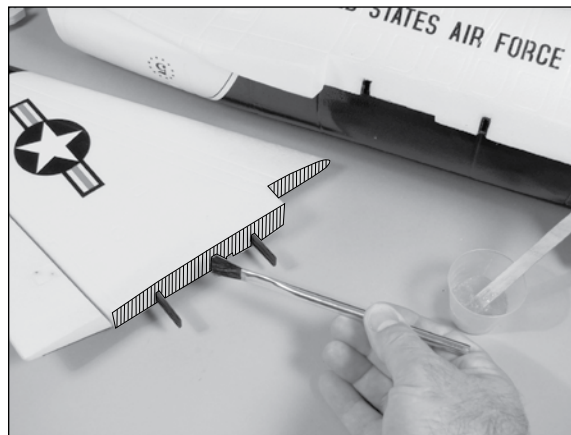

**Note:** You can use a paper towel that has had rubbing alcohol applied to it to remove any excess epoxy from your airframe. Use care not to get the alcohol on the decals as it could damage them.

- 3. Slide the wing panel back into position on the fuselage, pressing the wing tightly against the fuselage. It is best to hold the wing panel in position until the epoxy cures, as tape will damage the decal if it is applied directly to the decal. Be sure to check the alignment of the wing while the glue is drying. Use the picture in the next step for reference.



- 4. Fit the remaining wing panel to the fuselage. Stand 6–8 feet (3–4 meters) from the front of the airframe. When viewed from the front, both panels should be flat (parallel) along the bottom to be properly aligned. Use sandpaper to lightly sand the plastic joiner to correct the alignment.

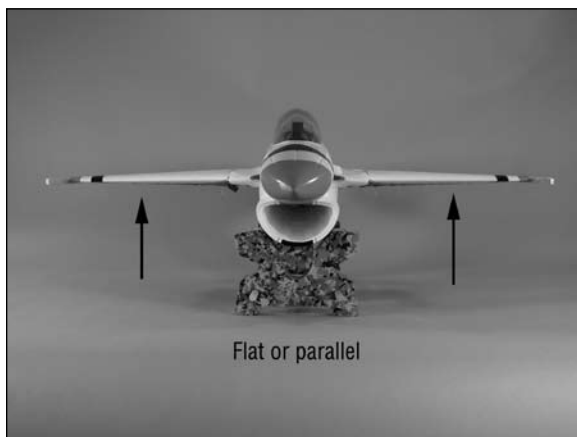

- 5. After fitting and aligning the second wing panel, repeat Steps 2 and 3 to glue the wing panel to the fuselage.
- 6. Before installing the stabilizer, you will need to break in the elevator hinges. This is done by flexing the elevator up and down a few times. Don't move the elevator too far and damage the hinge. Start with small movements and work up to an amount that will be slightly greater than the suggested high rate elevator control throw found on Page 31.



- 7. Check the fit of the stabilizer to the fuselage. Note that the control horn on the stabilizer will face toward the bottom of the fuselage when the stabilizer is installed.

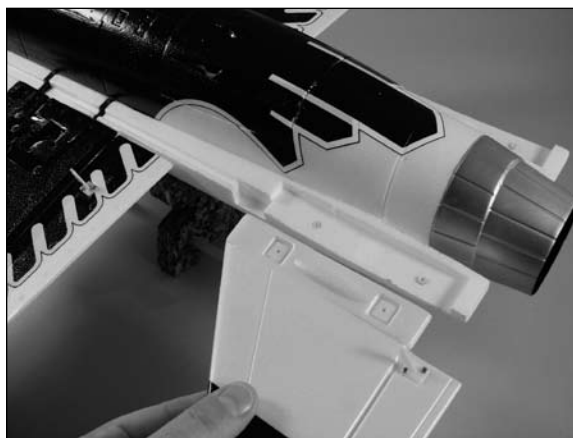

- 8. Use two 2mm x 12mm self-tapping screws and a #1 Phillips screwdriver to secure the stabilizer to the fuselage. Use care not to over-tighten the screws and cause damage to the fuselage or stabilizer.

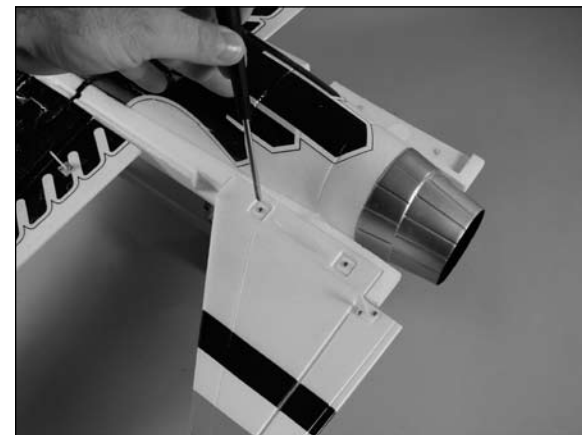

- 9. Repeat Steps 6 through 8 to attach the remaining stabilizer to the fuselage.



**Note:** The stabilizer tips will be lower than the center of the stabilizer at the fuselage when the fuselage is upright. This is scale for the F-16 and is correct.

## Elevator and Aileron Servo Installation

### Required Parts

- Servo (4)
- Assembled airframe
- Fuselage decal (right and left)
- 3-inch (76mm) servo extension (2)
- 9-inch (228mm) servo extension (2)
- Standard single-sided servo arm (4)
- 2<sup>7</sup>/<sub>8</sub>-inch (73mm) pushrod wire w/clevis (2)
- 5<sup>7</sup>/<sub>8</sub>-inch (150mm) pushrod wire w/clevis (2)

### Required Tools and Adhesives

- 6-minute epoxy
- Mixing cup
- Mixing stick
- Epoxy brush
- Paper towel
- Rubbing alcohol
- Sandpaper
- Phillips screwdriver: #00
- Hobby knife w/#11 blade

- 1. Use a hobby knife to trim the decal on the bottom of the wing to expose the pocket for the aileron servo. Prepare both the right and left wing at this time.

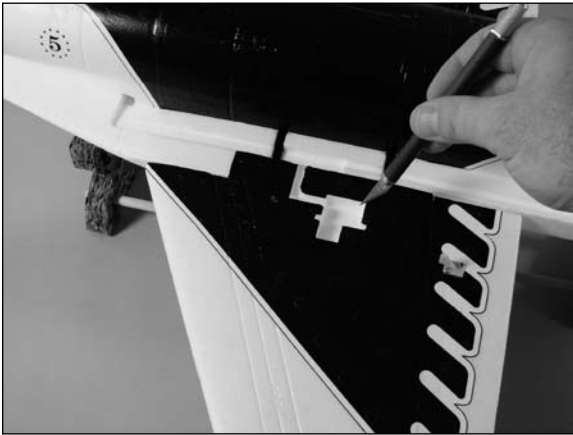

**E-tips**

You can use compressed air to blow away the remains of the decal.

**Note:** Before preparing the aileron and elevator servos for installation, it is suggested to read through the Radio Programming section of this manual beginning on Page 18. This section will guide you through setting up the necessary mixing required to operate the servos installed in your F-16. This mixing reduces the amount of complexity and extensions required, keeping the weight at its lowest for the best performance from your model.

- 2. Use your radio system to center the servos that will be used for the ailerons. Remove the stock servo horns from the servos using a #00 Phillips screwdriver and install the standard single-sided servo arm on the servos as shown. Make sure to prepare a right and left servo as shown.

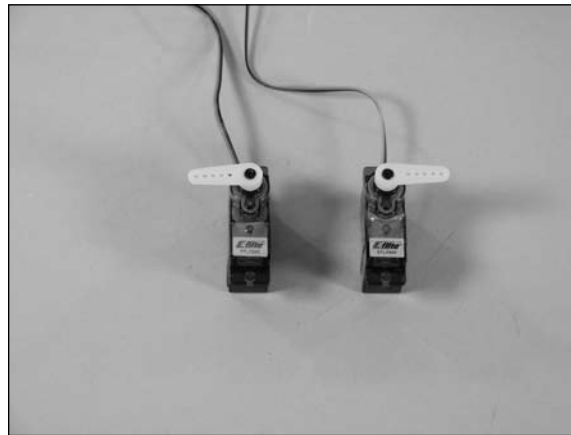

- 3. Test fit the aileron servo into the pocket in the bottom of the wing. Note that the servo output will face to the front of the aircraft.



- 4. Remove the servo and scuff the surface of the servo where it contacts the wing using sandpaper. Clear any residue left from the sanding process using a paper towel and rubbing alcohol. Mix a small amount of 6-minute epoxy. Place a small amount of epoxy in the servo pocket, then install the servo, pressing it into the epoxy. This will keep the servo secure in the wing during the operation of your model.

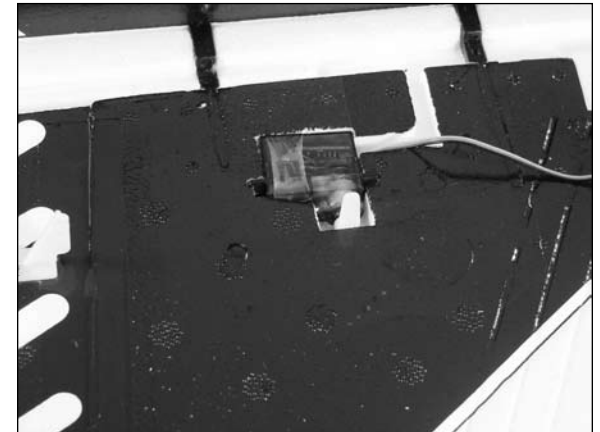

- 5. Repeat Steps 3 and 4 to install the aileron servo in the opposite wing panel.

## ***Etips***

Be very careful to use only a small amount of epoxy when attaching the servos. Using an excessive amount of glue could cause some of the excess to seep inside of the servo case and could bind the servo, resulting in servo failure.

- 6. Use your radio system to center the servos that will be used for the elevators. Remove the stock servo horns from the servos using a #00 Phillips screwdriver and install the standard single-sided servo arm on the servos as shown. Make sure to prepare a right and left servo as shown.

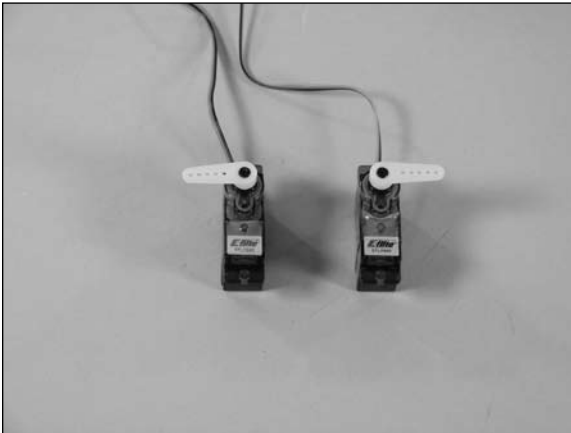

- 7. Test fit the elevator servo into the pocket on the side of the fuselage. Note that the servo output will face to the front of the aircraft. Remove the servo and scuff the surface of the servo that contacts the fuselage using sandpaper. Clear any residue left from the sanding process using a paper towel and rubbing alcohol. Mix a small amount of 6-minute epoxy. Place a small amount of epoxy in the servo pocket, then install the servo, pressing it into the epoxy. This will keep the servo secure in the fuselage during the operation of your model.



- 8. Connect a 9-inch (228mm) servo extension to the lead on the elevator servo. Tie a piece of string or dental floss around the connection to prevent the two from unplugging accidentally. Install an extension for both elevator servos at this time.



- 9. Connect a 3-inch (76mm) servo extension to the lead on the aileron servo. Tie a piece of string or dental floss around the connection to prevent the two from unplugging accidentally. Install an extension for both aileron servos at this time.

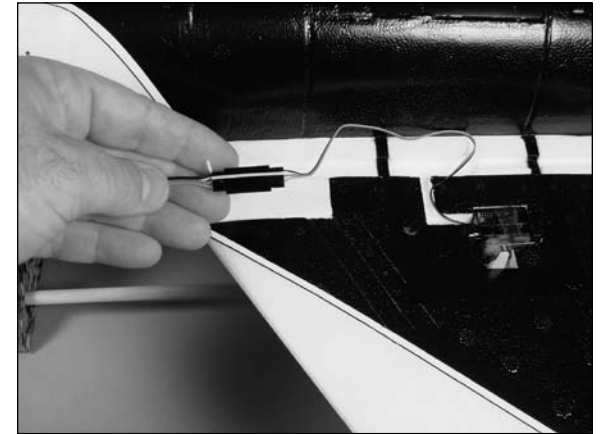

- 10. Carefully lay the extension from the elevator servos into the channel on each side of the fuselage. The aileron extension will then be placed on top of the elevator extension. Both extensions are then inserted into the fuselage where the channel turns to enter the fuselage.



## ***E-tips***

Before inserting the extension leads through the fuselage, mark each lead according to which servo it is connected to. (Right Elevator, Left Elevator—this will help with set up later). You can use a small tip marker or a piece of tape for this.

- 11. Locate the decal to cover the channel for the aileron and elevator extensions. A right and left decal has been supplied to cover the channels. Make sure to use the correct decal on each side of your aircraft.

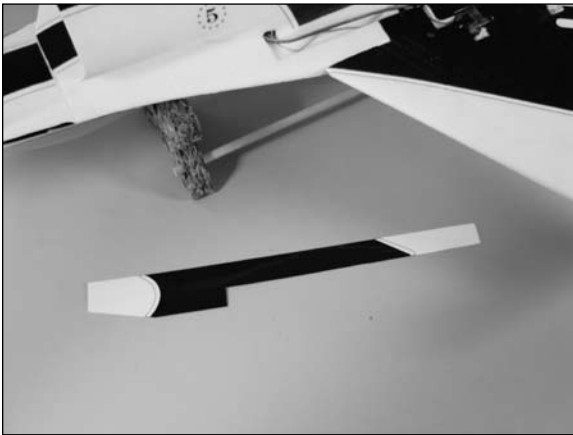

- 12. Remove the backing from the decal. Starting at the front, hold the rear of the decal up and align the trim scheme from the decal to the scheme on the aircraft. Carefully work toward the rear of the fuselage, pressing the decal down and guiding the extensions under the decal to remain in the channel.



## ***E-tips***

A water-based dark blue paint can be used to paint the exposed white foam that is shown on the wing where the servo lead runs through.

- ○ ○ ○ 13. Insert the end of the 5<sup>7</sup>/<sub>8</sub>-inch (150mm) pushrod wire with the clevis and "Z" bend into the hole of the servo arm that is in one hole from the end of the horn as shown. The pushrod will enter from the top of the horn. Insert the wire so it appears as shown in the second image.

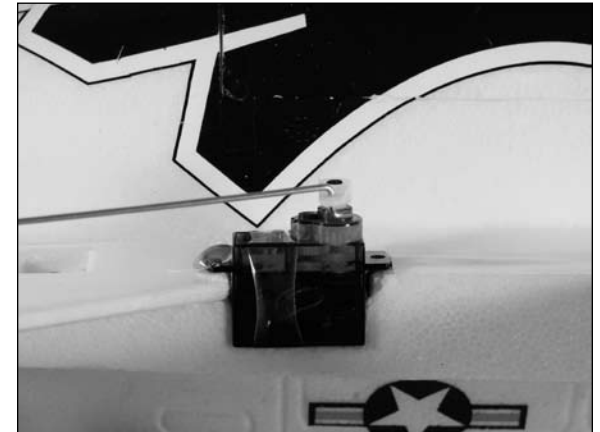

## ***E-tips***

You may have to slightly enlarge the hole in the servo horns for the pushrod wire. Use a sharp #11 blade to do this by twisting it in the hole on the top and bottom of the servo arm. Do this a small amount at a time as it will not need to enlarge the hole much.

- 14. Attach the clevis on the pushrod to the outer hole of the elevator control horn. Snap the clevis together so it is secure on the control horn.

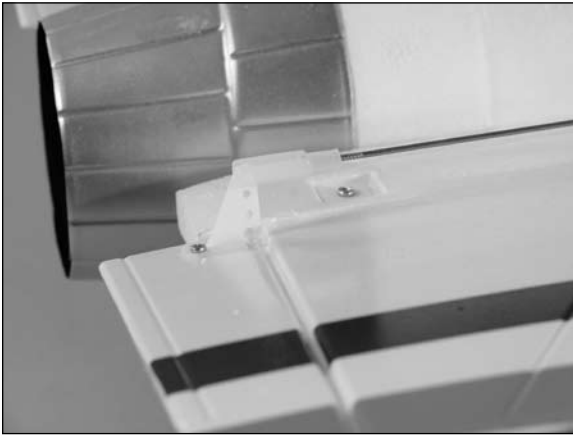

- 15. Repeat Steps 13 and 14 to install the second elevator linkage. The left and right linkages will be mirror images of each other when installed.

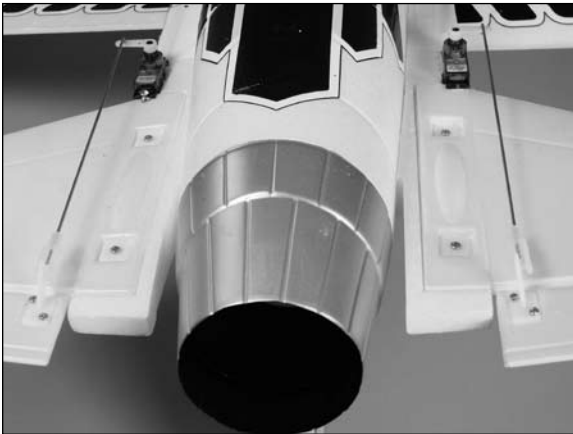

- 16. Repeat Steps 13 and 14 to install the 2<sup>7</sup>/<sub>8</sub>-inch (73mm) pushrod wire with clevis for the ailerons. The end at the servo will attach to the outermost hole in the aileron servo arm, and the clevis will attach to the outer hole on the control horn as shown. Make sure to install both the left and right aileron linkages at this time.

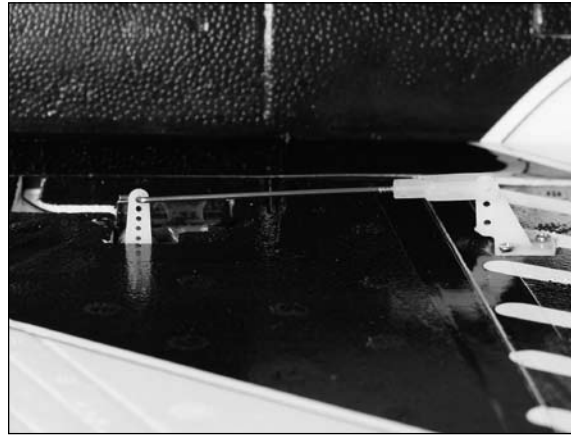

## Landing Gear Installation

### Required Parts

2mm nut                      Servo  
 Assembled fuselage  
 Long 3D servo horn  
 Nose gear wire w/wheel  
 Gear door (right and left)  
 Main landing gear w/wheels  
 2mm x 10mm machine screw  
 Brass steering arm bushing  
 1/16-inch wheel collar w/screw  
 Nose gear steering arm w/screw  
 2mm x 8mm self-tapping screw (4)

### Required Tools and Adhesives

Side cutter                      Pin drill  
 6-minute epoxy                Mixing cup  
 Mixing stick                    Epoxy brush  
 Paper towel                    Rubbing alcohol  
 Threadlock                      Sandpaper  
 Hobby knife w/#11 blade  
 Drill bit: 5/64-inch (2mm)  
 Phillips screwdriver: #00, #1

**Note:** The landing gear assembly is optional. The F-16 can be flown with or without the landing gear.

- 1. Use a #1 Phillips screwdriver and two 2mm x 8mm self-tapping screws to attach the landing gear door to the fuselage. The two holes for the screws have small holes so they can be located on the bottom of the fuselage. Note the direction of the gear door as shown with the narrow end of the door facing the front of the aircraft.

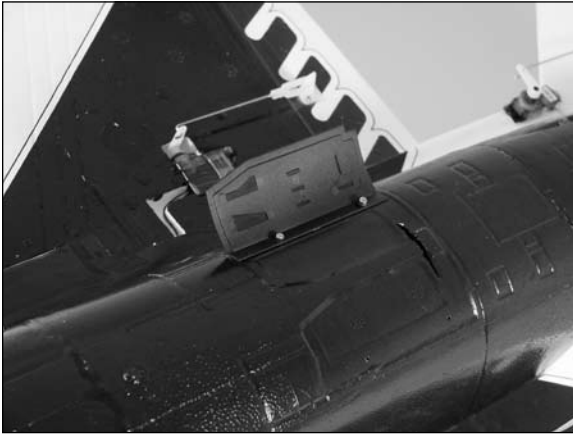

- 2. Repeat Step 1 to install the remaining gear door on the bottom of the fuselage.



- 3. Use a hobby knife with a #11 blade to remove the decal from the bottom of the fuselage to expose the slot for the main landing gear.



- 4. Insert the main landing gear into the slot in the bottom of the fuselage. You will need to flex the gear inward slightly to get it to fit into the slot.

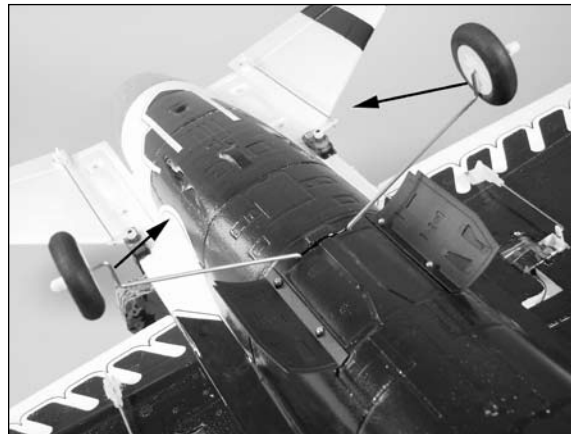

- 5. Lift the canopy hatch from the top of the fuselage. The hatch is held in position using four small magnets and will take a light amount of force to remove.



- 6. Locate a long 3D servo arm and use side cutters to remove one of the arms from the horn as shown.



- 7. Use a pin drill and 5/64-inch (2mm) drill bit to enlarge the outer hole on the servo arm.

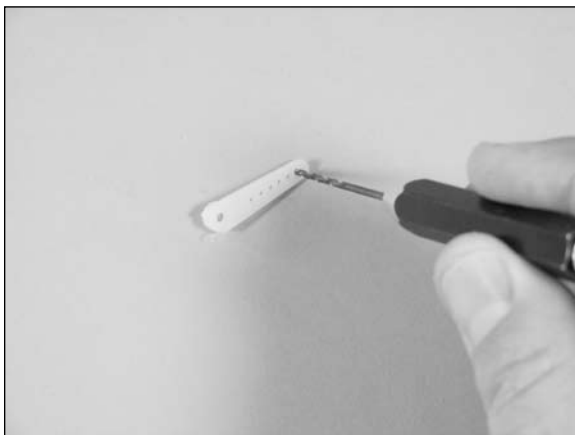

**Note:** Before installing the steering servo arm, it is suggested to read through the Radio Programming section of this manual found on Page 30.

- 8. Slide the 2mm x 10mm machine screw through the brass steering arm bushing.



- 9. Slide the brass steering arm bushing through the slot in the steering arm. Note the direction of the screw in relationship to the steering arm.



- 10. Use a #1 Phillips screwdriver to start the screw in to the outermost hole in the servo arm. Tighten the screw so the brass steering arm bushing is tight against the servo arm.

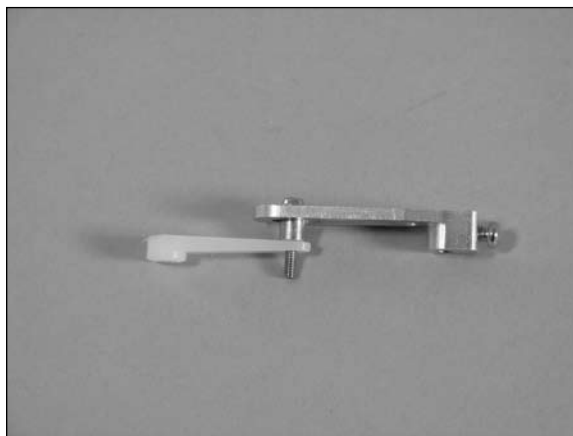

- 11. Thread a 2mm nut onto the screw from underneath the servo arm. Tighten the screw and nut to secure the bushing and steering arm. Always use threadlock on metal-to-metal fasteners to prevent them from vibrating loose.



- 12. Remove the original servo arm from the servo using a #00 Phillips screwdriver. After centering the steering servo, install the long 3D arm prepared in the previous steps on the servo as shown.



- 13. Test fit the steering servo into the pocket inside the fuselage. Note that the servo output faces to the rear of the aircraft. Remove the servo and scuff the surface of the servo that contacts the fuselage using sandpaper. Clear any residue left from the sanding process using a paper towel and rubbing alcohol. Mix a small amount of 6-minute epoxy. Place a small amount of epoxy in the servo pocket, then install the servo, pressing it into the epoxy. This will keep the servo secure in the fuselage during the operation of your model.



- 14. Locate the nose gear. Notice there is a slight bend to the gear wire. This bend will angle the gear forward in a scale-like manner when it has been installed.

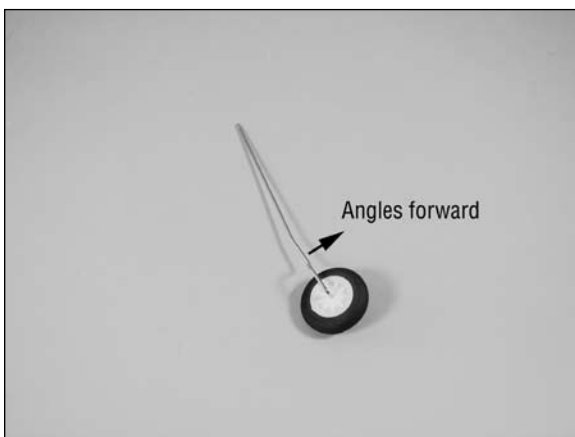

- 15. There are also two small flat areas on the nose gear that will face to the front of the aircraft. Please remember these flat areas for later in the nose gear installation.

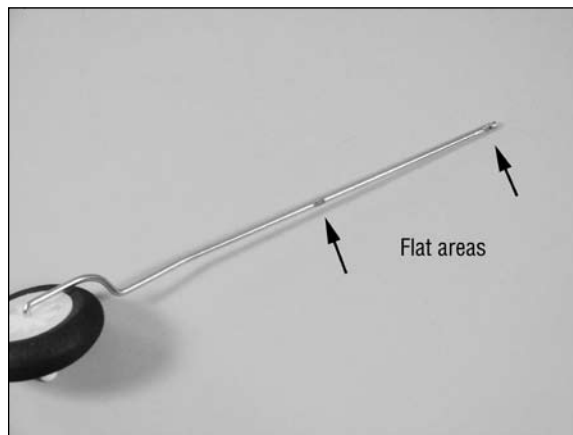

- 16. Use a hobby knife and #11 blade to remove the decal from the bottom of the fuselage to expose the slot for the nose gear wire.



- 17. Slide the nose gear into the slot from the bottom of the fuselage. You will need to slide the gear wire through the 1/16-inch wheel collar before it continues its journey into the fuselage as shown in the following photos.



- 18. The nose gear will slide into the hole in the steering arm as its final destination. The screw at the steering arm will then be tightened so it is resting in the flat area as indicated back in Step 14. Use a #1 Phillips screwdriver to tighten the screw in the steering arm. Always remember to use threadlock on metal-to-metal fasteners to prevent them from vibrating loose.

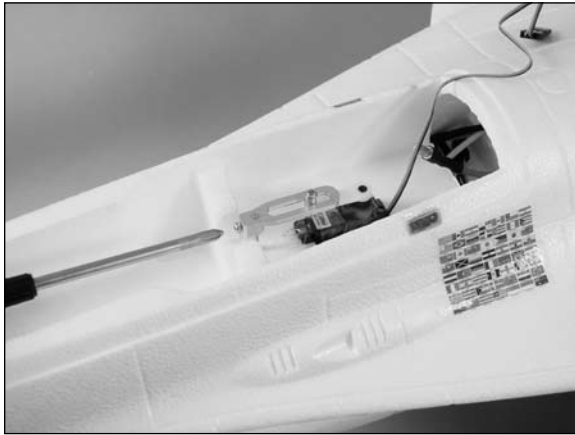

**Note:** The steering arm and wheel will be parallel to each other as illustrated below.

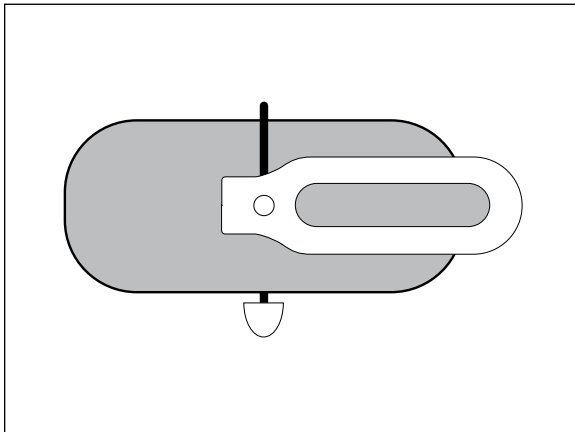

- 19. Position the gear so there is a gap of 1/32-inch (.5mm) between the steering arm and the servo horn so they do not bind during the operation of the nose gear. With the wheel collar resting lightly against the fuselage as shown, use a #1 Phillips screwdriver to tighten the screw in the wheel collar. The screw at the wheel collar will be tightened so it is resting in the flat area as indicated back in Step 14. Always remember to use threadlock on metal-to-metal fasteners to prevent them from vibrating loose.



### ***E-tips***

You can place a piece of paper between the steering arm and servo arm to achieve the correct amount of gap before securing the wheel collar.

## **Speed Control and Receiver Installation**

### **Required Parts**

Speed control  
Receiver

Assembled airframe  
Hook and loop tape

**Note:** Due to the current draw of the system and the location of the electronics. We recommend that throttle management is used during each flight. Using full power throughout the duration of the flight will result in shorter flight times and could result in a shorter life span for the electronics and batteries.

- 1. Plug the wires from the speed control and motor together. The wires from the motor will be just long enough that they can be accessed from the cockpit area of your model.



- 2. Apply a small piece of hook and loop tape to the bottom of the speed control.



**Note:** Work through Step 3 before removing the backing from the hook and loop tape. Installation of the speed control can be tricky, and the stickiness of the hook and loop tape will make the installation even trickier. Keeping the backing on until ready will allow you to practice the installation of the speed control before your final performance.

- 3. Install the speed control back in the fuselage as indicated on the photos. You will need to guide the motor wires into the fuselage while installing the speed control.



## ***Etips***

Be sure to set the speed control to the correct timing for this type of motor. The timing should be set for 2-pole motors.

**Note:** Before plugging in the servos, it is suggested to read through the Radio Programming section of this manual beginning on Page 18. This section will guide you through setting up the necessary mixing required to operate the servos installed in your F-16. This mixing reduces the amount of complexity and extensions required, keeping the weight at its lowest for the best performance from your model.

- 4. Plug the extensions from the ailerons and elevators into the proper ports of the receiver. Also plug the lead from the steering servo and speed control into their proper ports on the receiver as well.

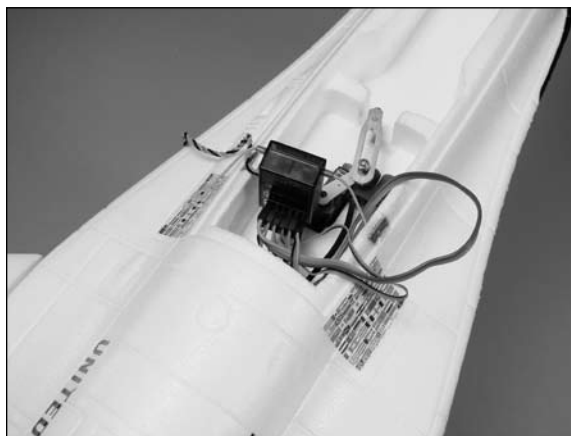

- 5. Use a small piece of hook and loop tape to mount the receiver in the fuselage as shown. The edge of the receiver should be flush with the edge of the cockpit opening as seen in the following step.

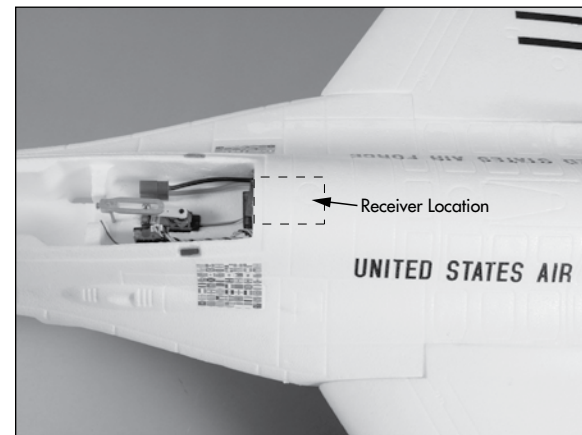

- 6. Use a small piece of hook and loop tape to mount the remote receiver alongside of the steering servo. Make sure the position of the remote receiver will not interfere with the operation of the steering servo when it is installed.



## ***Vertical and Ventral Fin Installation***

### ***Required Parts***

Vertical fin                      Assembled airframe  
 Ventral fin (right and left)

### ***Required Tools and Adhesives***

6-minute epoxy              Mixing cup  
 Mixing stick                 Epoxy brush  
 Paper towel                 Rubbing alcohol  
 Sandpaper                    Hobby knife w/#11 blade

- ○ 1. Use a hobby knife w/#11 blade to trim the decal from the opening on the bottom of the fuselage for the ventral fin. Prepare the slots for both the left and right ventral fins at this time.

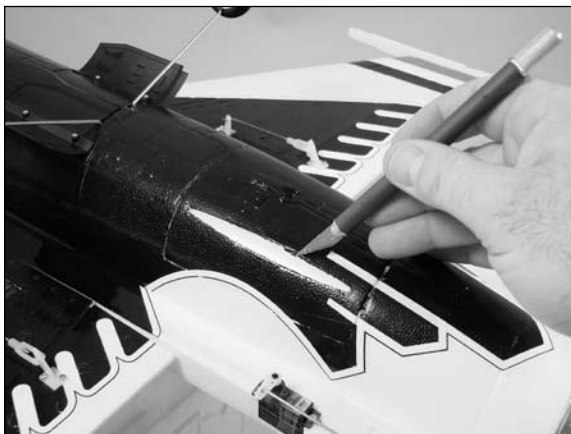

- ○ 2. Test fit the ventral fin in the slot on the bottom of the fuselage. The taller portion of the fin will face to the front of the fuselage and the decal will face to the wing tip. Once satisfied with the fit remove the fin from the fuselage. Mix a small amount of 6-minute epoxy. Apply the epoxy in the slot and insert the ventral fin in the slot. Allow the epoxy to fully cure before proceeding to the fin installation.



- 3. Repeat Steps 1 and 2 to install the remaining ventral fin on the bottom of the fuselage.



- 4. Insert the vertical fin into the pocket on the top of the fuselage. Stand 6–8 feet (3–4 meters) from the rear of the airframe. Check that the angle between the wing panels and fin are equal. The position of the fin can be moved to correct for any alignment issues. Once satisfied with the fit, remove the fin from the fuselage. Prepare 1/4-ounce (10cc) of 6-minute epoxy and brush a light coating on the fin and in the pocket on the fuselage where they contact each other. Insert the fin back into the pocket and check the alignment again. As the epoxy cures, continue to check the alignment of the fin to the wing until the epoxy has fully cured.



## Motor Battery Installation

### Required Parts

Motor battery      Assembled airframe  
Hook and loop tape

- 1. Apply the hook and loop tape to the bottom of the battery. Use the softer fabric side of the hook and loop tape on the battery.



- 2. Apply the hook and loop tape inside the fuselage in the battery compartment. Use the harder plastic side of the hook and loop tape on the battery.



- 3. Place the battery into the battery compartment in the fuselage. The battery will be positioned as far back in the compartment as possible to achieve the correct Center of Gravity when you are using the recommended setup.



## Missile Installation (Optional)

### Required Parts

Missile (2) Assembled airframe

### Required Tools and Adhesives

Medium CA

**Note:** The installation of the missiles on your model is not scale for this paint scheme and is considered optional. The missiles will be attached permanently and will not affect the flight performance.

- 1. Locate the missile included with your model. Inspect each missile to locate the flat areas between the fins of the missile. These flat areas are the gluing surfaces used for their installation.

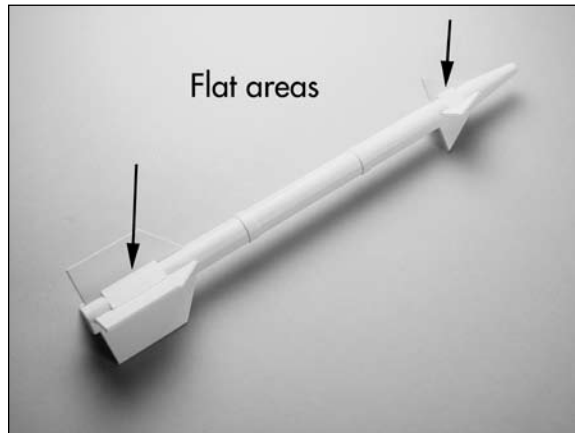

- 2. The missile rails on the wing have flat spots that will correspond to the flat areas on the missile.

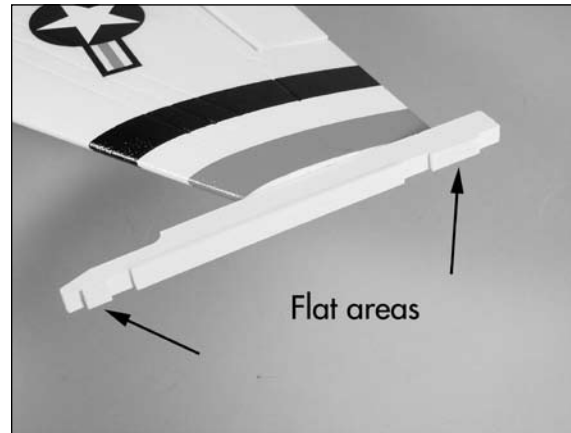

- 3. Use medium CA to glue the missile to the mount at the wing tip. Allow the CA to fully cure before installing the remaining missile.

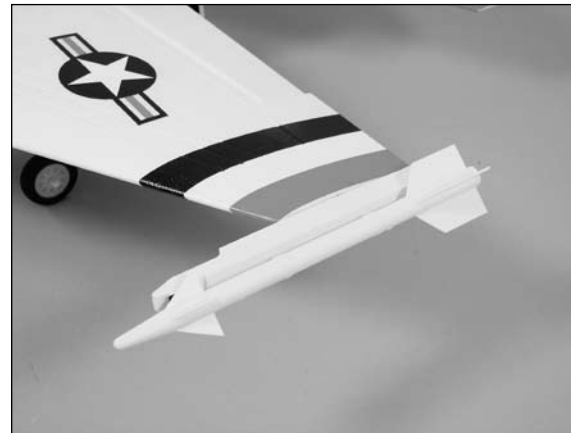

- 4. Repeat Steps 1 through 3 to install the remaining missile to the mount on the opposite wing tip.

## Removing Fan and Motor for Servicing or Replacement

### Required Tools and Adhesives

6-minute epoxy	Mixing cup
Mixing stick	Epoxy brush
Paper towel	Rubbing alcohol
Sandpaper	Hobby knife w/#11 blade

Please note that the hatch is glued in with small amounts of glue at certain places on the hatch. We have done this for ease of removal if necessary. If you have removed your hatch we suggest that you glue it back in at the same glue locations with a small amount of 6 minute epoxy. We also suggest that you use a fresh sharp #11 blade to make all cuts. This will help make the process easier and the cut line will be smaller, cleaner and much less noticeable.

- 1. Start by using a hobby knife and #11 blade to cut the decal around the seam of the motor hatch located at the back of the airframe. Note this hatch is located at the same point as where the ventral fins are mounted.



- 2. Use a hobby knife with a #11 blade, or a razor saw with a fine tooth blade, to cut through the glue joint on the front and rear seam lines of the hatch.



- 3. Using a hobby knife and #11 blade, cut down the side seams of the hatch at approximately a 45-degree angle to the horizontal line of the fuselage.

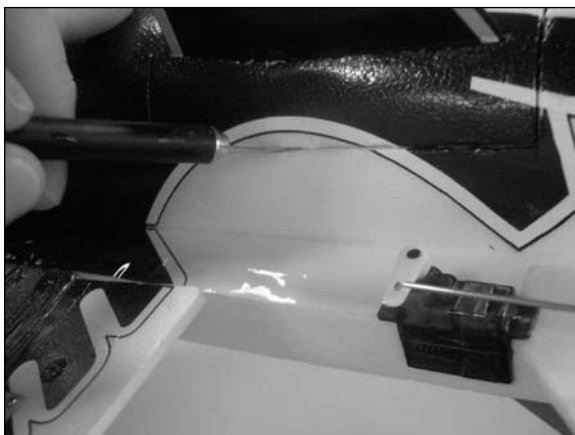

- 4. Once you are sure that you have cut through the hatch joints all the way around the hatch, use a small amount of force to rock the hatch in a rolling motion side to side. A small amount of movement should break loose the last glue joint on the top of the fan unit and remove the hatch/fan assembly.

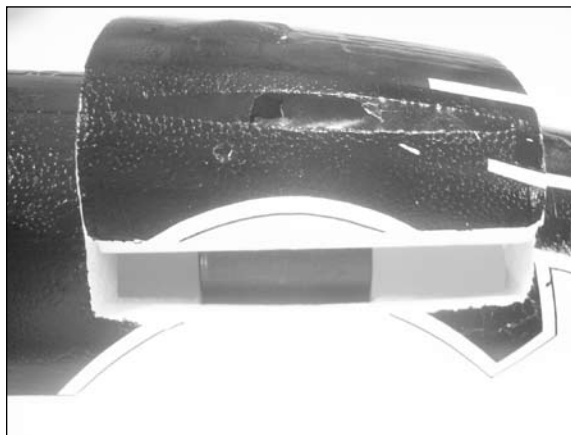

**Note:** When gluing the hatch back in position make sure that the motor wires are routed in the slot on the top of the fuselage. If they are not in this slot the hatch will not seat properly.

## Radio Programming

The programming listed is showing the base radio set up for the Spektrum DX6i radio. This programming will allow you to use the gear channel (channel #5) for the second elevator servo. This will eliminate the need for any servo reversers or Y-harnesses. It will also show you how to use a P-MIX to turn off the gear channel switch when using this channel for a control surface. If you choose not to use a computer radio for your F-16, you will be required to use a Y-harness for the ailerons (EFLRYH3) and a servo reversing Y-harness (EXRA320) for the elevators.

### ***E-tips***

Travel Adjust, Sub Trim and Dual Rates are not listed and should be adjusted according to each individual model and preference.

**Note:** The programming listed is using the electronics that we have recommended. Using other types of equipment may require changes to the set up.

<b>Channel List</b>	<b>Servo Receiver Port</b>
Throttle	THRO
Right Aileron	AILE
Right Elevator	ELEV
Rudder	RUDD
Left Elevator	GEAR
Left Aileron	AUX 1

### Reversing

Throttle	N
Right Aileron	N
Right Elevator	R
Rudder	R
Gear/Left Elevator	R
Aux1/Left Aileron	N

### Wing and Tail Mix

DUALAILE	ACT (This will activate the left aileron)
V-tail	INH
ELEVON	INH

### MIX 1 (This mix will deactivate the gear channel switch)

GEAR	GEAR ACT
Rate	D -100%, U -100%
SW ON	TRIM INH

### MIX 2 (This mix will activate the left elevator half)

ELEV	GEAR ACT
Rate	D +100%, U +100%
SW ON	TRIM ACT

## Control Throws

- 1. Turn on the transmitter and receiver of your F-16. Check the movement of the rudder using the transmitter. When the stick is moved right, the rudder should also move right. Reverse the direction of the servo at the transmitter if necessary.
- 2. Check the movement of the elevator with the radio system. Moving the elevator stick down will make the airplane elevator move up.
- 3. Check the movement of the ailerons with the radio system. Moving the aileron stick right will make the right aileron move up and the left aileron move down.
- 4. Use a ruler to adjust the throw of the elevator, ailerons and rudder. Adjust the position of the pushrod at the control horn to achieve the following measurements when moving the sticks to their endpoints.

### Aileron High Rate

Up	1-inch	(25mm)
Down	7/8-inch	(22mm)

### Aileron Low Rate

Up	3/4-inch	(19mm)
Down	5/8-inch	(16mm)

### Elevator High Rate

Up	3/8-inch	(10mm)
Down	3/8-inch	(10mm)

### Elevator Low Rate

Up	1/4-inch	(7mm)
Down	1/4-inch	(7mm)

**Note:** Measurements are taken at the inner or widest point on the control surface.

### Nose Wheel Steering (High Rate or Taxi)

Left	7/16-inch	(12mm)
Right	7/16-inch	(12mm)

### Nose Wheel Steering (Low Rate or Takeoff)

Left	1/4-inch	(7mm)
Right	1/4-inch	(7mm)

**Note:** Steering measurement is taken at the end of the Aluminum Steering Arm over the steering servo arm.

These are general guidelines measured from our own flight tests. You can experiment with higher rates to match your preferred style of flying.

## Center of Gravity

An important part of preparing the aircraft for flight is properly balancing the model.

**Caution: Do not inadvertently skip this step!**

The recommended Center of Gravity (CG) location for the F-16 is  $2\frac{3}{16}$ – $2\frac{9}{16}$ -inch (55–65mm) back from the leading edge of the wing. Mark the location for the Center of Gravity on the bottom of the wing next to the fuselage as shown.

When balancing your F-16, support the plane rightside-up at the marks made on the bottom of the wing with your fingers or a commercially available balancing stand. Adjust components as necessary so the model hangs level or slightly nose down. This is the correct balance point for your model. You might find with the different power and landing gear configurations that you need to shift the battery slightly in the compartment or add a small amount of weight to either the front or back of the fuselage to achieve the correct balance.

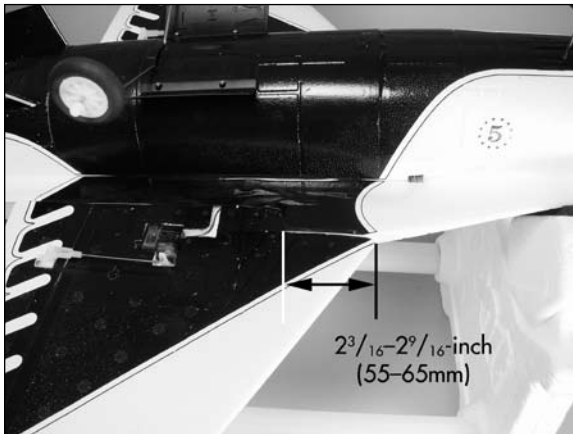

After the first flights, the CG position can be adjusted for your personal preference.

## Preflight

### Check Your Radio

Before going to the field, be sure that your batteries are fully charged per the instructions included with your radio. Charge both the transmitter and receiver pack for your airplane. Use the recommended charger supplied with your particular radio system, following the instructions provided with the radio. In most cases, the radio should be charged the night before going out flying.

Before each flying session, be sure to range check your radio. See your radio manual for the recommended range and instructions for your radio system. Each radio manufacturer specifies different procedures for their radio systems. Next, start the motor. With the model securely anchored, check the range again. The range test should not be significantly affected. If it is, don't attempt to fly! Have your radio equipment checked out by the manufacturer.

**Note:** Keep loose items that can get entangled in the propeller away from the prop. These include loose clothing, or other objects such as pencils and screwdrivers. Especially keep your hands away from the propeller.

Double-check that all controls (aileron, elevator, rudder and throttle) move in the correct direction.

Check the radio installation and make sure all the control surfaces are moving correctly (i.e. the correct direction and with the recommended throws). Test run the motor and make sure it transitions smoothly from off to full throttle and back. Also ensure the engine is installed according to the manufacturer's instructions, and it will operate consistently.

Check all the control horns, servo horns, and clevises to make sure they are secure and in good condition. Replace any items that would be considered questionable. Failure of any of these components in flight would mean the loss of your aircraft.

## Range Test Your Radio

- 1. Before each flying session, be sure to range check your radio. This is accomplished by turning on your transmitter with the antenna collapsed. Turn on the receiver in your airplane. With your airplane on the ground and the engine running, you should be able to walk 30 paces (approximately 100 feet) away from your airplane and still have complete control of all functions.

If not, don't attempt to fly! Have your radio equipment checked out by the manufacturer.

- 2. Double-check that all controls (aileron, elevator, rudder and throttle) move in the correct direction.
- 3. Be sure that your transmitter batteries are fully charged, per the instructions included with your radio.

## Flying Your F-16

---

Flying the F-16 is a thrill and a treat all in one. Enjoy flying airshow maneuvers as you pretend to be the lead solo pilot for the USAF Thunderbirds airshow team. You will find that the lightweight, agile F-16 is very capable in the air yet docile for slow speed flight, approach and landings.

If you elect to fly the F-16 without the landing gear, you will need to hand launch the model. Hold the model underneath the wing around the same area as where the main landing gear would be mounted. Launch the model with full power and a slightly nose-high attitude. You will find that the F-16 does not require a hard launch and will fly out of your hand without hesitation.

When using the landing gear, we suggest using the lower rate throws listed in the control throws section for the nose gear on takeoff and landing due to the narrow stance of the gear on an F-16. Line the model up pointing into the wind and apply full power. Hold a small amount of up elevator. The F-16 will rotate smoothly around 150 feet. After rotation, ease off of the up elevator and climb to altitude.

The F-16 tracks well in the air and is capable of many basic aerobatic maneuvers like loops, rolls, and inverted flight. We do recommend that you use throttle management during the whole flight. Using full power throughout the duration of the flight will result in shorter flight times and could result in a shorter life span for the electronics and batteries. Once you are ready to land, pull the power back and begin a slightly nose-high approach using throttle to control your descent. The F-16 will land at a slightly nose-high angle and roll out down the runway.

Happy Landings!

## Safety, Precautions, and Warnings

---

As the user of this product, you are solely responsible for operating it in a manner that does not endanger yourself and others or result in damage to the product or the property of others.

Carefully follow the directions and warnings for this and any optional support equipment (chargers, rechargeable battery packs, etc.) that you use.

This model is controlled by a radio signal that is subject to interference from many sources outside your control. This interference can cause momentary loss of control so it is necessary to always keep a safe distance in all directions around your model, as this margin will help to avoid collisions or injury.

- Always operate your model in an open area away from cars, traffic or people.
- Avoid operating your model in the street where injury or damage can occur.
- Never operate the model out into the street or populated areas for any reason.
- Never operate your model with low transmitter batteries.
- Carefully follow the directions and warnings for this and any optional support equipment (chargers, rechargeable battery packs, etc.) that you use.
- Keep all chemicals, small parts and anything electrical out of the reach of children.
- Moisture causes damage to electronics. Avoid water exposure to all equipment not specifically designed and protected for this purpose.

## Warranty Information

---

### Warranty Period

---

Horizon Hobby, Inc., (Horizon) warrants that the Products purchased (the "Product") will be free from defects in materials and workmanship at the date of purchase by the Purchaser.

## Limited Warranty

---

(a) This warranty is limited to the original Purchaser ("Purchaser") and is not transferable. REPAIR OR REPLACEMENT AS PROVIDED UNDER THIS WARRANTY IS THE EXCLUSIVE REMEDY OF THE PURCHASER. This warranty covers only those Products purchased from an authorized Horizon dealer. Third party transactions are not covered by this warranty. Proof of purchase is required for warranty claims. Further, Horizon reserves the right to change or modify this warranty without notice and disclaims all other warranties, express or implied.

(b) Limitations- HORIZON MAKES NO WARRANTY OR REPRESENTATION, EXPRESS OR IMPLIED, ABOUT NON-INFRINGEMENT, MERCHANTABILITY OR FITNESS FOR A PARTICULAR PURPOSE OF THE PRODUCT. THE PURCHASER ACKNOWLEDGES THAT THEY ALONE HAVE DETERMINED THAT THE PRODUCT WILL SUITABLY MEET THE REQUIREMENTS OF THE PURCHASER'S INTENDED USE.

(c) Purchaser Remedy- Horizon's sole obligation hereunder shall be that Horizon will, at its option, (i) repair or (ii) replace, any Product determined by Horizon to be defective. In the event of a defect, these are the Purchaser's exclusive remedies. Horizon reserves the right to inspect any and all equipment involved in a warranty claim. Repair or replacement decisions are at the sole discretion of Horizon. This warranty does not cover cosmetic damage or damage due to acts of God, accident, misuse, abuse, negligence, commercial use, or modification of or to any part of the Product. This warranty does not cover damage due to improper installation, operation, maintenance, or attempted repair by anyone other than Horizon. Return of any goods by Purchaser must be approved in writing by Horizon before shipment.

## Damage Limits

HORIZON SHALL NOT BE LIABLE FOR SPECIAL, INDIRECT OR CONSEQUENTIAL DAMAGES, LOSS OF PROFITS OR PRODUCTION OR COMMERCIAL LOSS IN ANY WAY CONNECTED WITH THE PRODUCT, WHETHER SUCH CLAIM IS BASED IN CONTRACT, WARRANTY, NEGLIGENCE, OR STRICT LIABILITY. Further, in no event shall the liability of Horizon exceed the individual price of the Product on which liability is asserted. As Horizon has no control over use, setup, final assembly, modification or misuse, no liability shall be assumed nor accepted for any resulting damage or injury. By the act of use, setup or assembly, the user accepts all resulting liability.

If you as the Purchaser or user are not prepared to accept the liability associated with the use of this Product, you are advised to return this Product immediately in new and unused condition to the place of purchase.

Law: These Terms are governed by Illinois law (without regard to conflict of law principals).

## Safety Precautions

This is a sophisticated hobby Product and not a toy. It must be operated with caution and common sense and requires some basic mechanical ability. Failure to operate this Product in a safe and responsible manner could result in injury or damage to the Product or other property. This Product is not intended for use by children without direct adult supervision. The Product manual contains instructions for safety, operation and maintenance. It is essential to read and follow all the instructions and warnings in the manual, prior to assembly, setup or use, in order to operate correctly and avoid damage or injury.

## Questions, Assistance, and Repairs

Your local hobby store and/or place of purchase cannot provide warranty support or repair. Once assembly, setup or use of the Product has been started, you must contact Horizon directly. This will enable Horizon to better answer your questions and service you in the event that you may need any assistance. For questions or assistance, please direct your email to [productsupport@horizonhobby.com](mailto:productsupport@horizonhobby.com), or call 877.504.0233 toll free to speak to a service technician.

## Inspection or Repairs

If this Product needs to be inspected or repaired, please call for a Return Merchandise Authorization (RMA). Pack the Product securely using a shipping carton. Please note that original boxes may be included, but are not designed to withstand the rigors of shipping without additional protection.

Ship via a carrier that provides tracking and insurance for lost or damaged parcels, as **Horizon is not responsible for merchandise until it arrives and is accepted at our facility**. A Service Repair Request is available at [www.horizonhobby.com](http://www.horizonhobby.com) on the "Support" tab. If you do not have internet access, please include a letter with your complete name, street address, email address and phone number where you can be reached during business days, your RMA number, a list of the included items, method of payment for any non-warranty expenses and a brief summary of the problem. Your original sales receipt must also be included for warranty consideration. Be sure your name, address, and RMA number are clearly written on the outside of the shipping carton.

## Warranty Inspection and Repairs

**To receive warranty service, you must include your original sales receipt** verifying the proof-of-purchase date. Provided warranty conditions have been met, your Product will be repaired or replaced free of charge. Repair or replacement decisions are at the sole discretion of Horizon Hobby.

## Non-Warranty Repairs

**Should your repair not be covered by warranty the repair will be completed and payment will be required without notification or estimate of the expense unless the expense exceeds 50% of the retail purchase cost.** By submitting the item for repair you are agreeing to payment of the repair without notification. Repair estimates are available upon request. You must include this request with your repair. Non-warranty repair estimates will be billed a minimum of ½ hour of labor. In addition you will be billed for return freight. Please advise us of your preferred method of payment. Horizon accepts money orders and cashiers checks, as well as Visa, MasterCard, American Express, and Discover cards.

If you choose to pay by credit card, please include your credit card number and expiration date. Any repair left unpaid or unclaimed after 90 days will be considered abandoned and will be disposed of accordingly. **Please note: non-warranty repair is only available on electronics and model engines.**

Electronics and engines requiring inspection or repair should be shipped to the following address:

Horizon Service Center  
4105 Fieldstone Road  
Champaign, Illinois 61822

or  
Horizon Hobby UK  
Units 1-4, Ployters Road  
Staple Tye - Southern Way  
Harlow  
Essex  
CM187NS  
United Kingdom

or  
Horizon Technischer Service  
Otto-Hahn-Str. 9a  
25337 Elmshorn  
Germany

**USA: Please call 1 877 504 0233 or visit [horizonhobby.com](http://horizonhobby.com) to find our distributor for your country for support with any questions or concerns regarding this product or warranty.**

**UK: Please call +44 1279 641 097 or [sales@horizonhobby.co.uk](mailto:sales@horizonhobby.co.uk) with any questions or concerns regarding this product or warranty.**

**Germany: Please call +49 4121 46199 66 or [service@horizonhobby.de](mailto:service@horizonhobby.de) with any questions or concerns regarding this product or warranty.**

## Instructions for Disposal of WEEE by Users in the European Union

This product must not be disposed of with other waste. Instead, it is the user's responsibility to dispose of their waste equipment by handing it over to a designated collection point for the recycling of waste electrical and electronic equipment. The separate collection and recycling of your waste equipment at the time of disposal will help to conserve natural resources and ensure that it is recycled in a manner that protects human health and the environment. For more information about where you can drop off your waste equipment for recycling, please contact your local city office, your household waste disposal service or where you purchased the product.



# 2008 Official Academy of Model Aeronautics Safety Code

## GENERAL

1. A model aircraft shall be defined as a non-human-carrying device capable of sustained flight in the atmosphere. It shall not exceed limitations established in this code and is intended to be used exclusively for recreational or competition activity.
2. The maximum takeoff weight of a model aircraft, including fuel, is 55 pounds, except for those flown under the AMA Experimental Aircraft Rules.
3. I will abide by this Safety Code and all rules established for the flying site I use. I will not willfully fly my model aircraft in a reckless and/or dangerous manner.
4. I will not fly my model aircraft in sanctioned events, air shows, or model demonstrations until it has been proven airworthy.
5. I will not fly my model aircraft higher than approximately 400 feet above ground level, when within three (3) miles of an airport without notifying the airport operator. I will yield the right-of-way and avoid flying in the proximity of full-scale aircraft, utilizing a spotter when appropriate.
6. I will not fly my model aircraft unless it is identified with my name and address, or AMA number, inside or affixed to the outside of the model aircraft. This does not apply to model aircraft flown indoors.
7. I will not operate model aircraft with metal-blade propellers or with gaseous boosts (other than air), nor will I operate model aircraft with fuels containing tetranitromethane or hydrazine.
8. I will not operate model aircraft carrying pyrotechnic devices which explode burn, or propel a projectile of any kind. Exceptions include Free Flight fuses or devices that burn producing smoke and are securely attached to the model aircraft during flight. Rocket motors up to a G-series size may be used, provided they remain firmly attached to the model aircraft during flight. Model rockets may be flown in accordance with the National Model Rocketry Safety Code; however, they may not be launched from model aircraft. Officially designated AMA Air Show Teams (AST) are authorized to use devices and practices as defined within the Air Show Advisory Committee Document.

9. I will not operate my model aircraft while under the influence of alcohol or within eight (8) hours of having consumed alcohol.
10. I will not operate my model aircraft while using any drug which could adversely affect my ability to safely control my model aircraft.
11. Children under six (6) years old are only allowed on a flightline or in a flight area as a pilot or while under flight instruction.
12. When and where required by rule, helmets must be properly worn and fastened. They must be OSHA, DOT, ANSI, SNELL or NOCSAE approved or comply with comparable standards.

## RADIO CONTROL

1. All model flying shall be conducted in a manner to avoid over flight of unprotected people.
2. I will have completed a successful radio equipment ground-range check before the first flight of a new or repaired model aircraft.
3. I will not fly my model aircraft in the presence of spectators until I become a proficient flier, unless I am assisted by an experienced pilot.
4. At all flying sites a line must be established, in front of which all flying takes place. Only personnel associated with flying the model aircraft are allowed at or in front of the line. In the case of airshows demonstrations straight line must be established. An area away from the line must be maintained for spectators. Intentional flying behind the line is prohibited.
5. I will operate my model aircraft using only radio-control frequencies currently allowed by the Federal Communications Commission (FCC). Only individuals properly licensed by the FCC are authorized to operate equipment on Amateur Band frequencies.
6. I will not knowingly operate my model aircraft within three (3) miles of any preexisting flying site without a frequency-management agreement. A frequency-management agreement may be an allocation of frequencies for each site, a day-use agreement between sites, or testing which determines that no interference exists. A frequency-management agreement may exist between two or more AMA chartered clubs, AMA clubs and individual AMA members, or individual AMA members. Frequency-management agreements, including an interference test report if the agreement indicates no interference exists, will be signed by all parties and copies provided to AMA Headquarters.
7. With the exception of events flown under official AMA rules, no powered model may be flown outdoors closer than 25 feet to any individual, except for the pilot and located at the flightline.

8. Under no circumstances may a pilot or other person touch a model aircraft in flight while it is still under power, except to divert it from striking an individual.
9. Radio-controlled night flying is limited to low-performance model aircraft (less than 100 mph). The model aircraft must be equipped with a lighting system which clearly defines the aircraft's attitude and direction at all times.
10. The operator of a radio-controlled model aircraft shall control it during the entire flight, maintaining visual contact without enhancement other than by corrective lenses that are prescribed for the pilot. No model aircraft shall be equipped with devices which allow it to be flown to a selected location which is beyond the visual range of the pilot.

## PARK FLYER SAFE OPERATING RECOMMENDATIONS

- Inspect your model before every flight to make certain it is airworthy.
- Be aware of any other radio frequency user who may present an interference problem.
- Always be courteous and respectful of other users of your selected flight area.
- Choose an area clear of obstacles and large enough to safely accommodate your flying activity.
- Make certain this area is clear of friends and spectators prior to launching your aircraft.
- Be aware of other activities in the vicinity of your flight path that could cause potential conflict.
- Carefully plan your flight path prior to launch.
- Abide by any and all established AMA National Model Aircraft Safety Code.



© 2008 Horizon Hobby, Inc.  
4105 Fieldstone Road  
Champaign, Illinois 61822  
(877) 504-0233  
[horizonhobby.com](http://horizonhobby.com)  
[E-fliteRC.com](http://E-fliteRC.com)