

Eclipse 360 BNF Basic

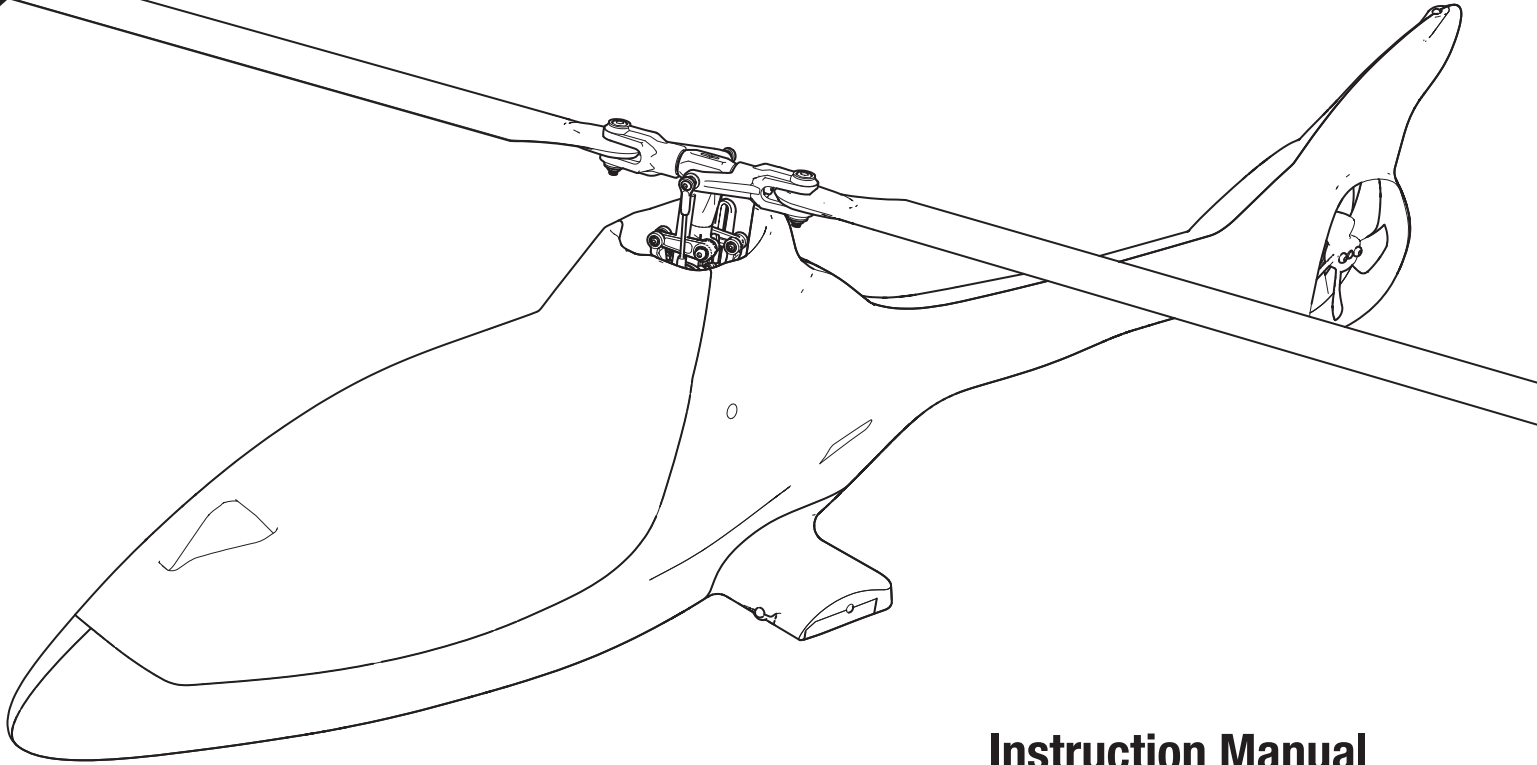

**Instruction Manual
Bedienungsanleitung
Manuel d'utilisation
Manuale di Istruzioni**

Scan the QR code and select the Manuals and Support quick links from the product page for the most up-to-date manual information.

Scannen Sie den QR-Code und wählen Sie auf der Produktseite die Quicklinks Handbücher und Unterstützung, um die aktuellsten Informationen zu Handbücher.

Scannez le code QR et sélectionnez les liens rapides Manuals and Support sur la page du produit pour obtenir les informations les plus récentes sur le manuel.

Scannerizzare il codice QR e selezionare i Link veloci Manuali e Supporto dalla pagina del prodotto per le informazioni manuali più aggiornate.



NOTICE

All instructions, warranties and other collateral documents are subject to change at the sole discretion of Horizon Hobby, LLC. For up-to-date product literature, visit horizonhobby.com or towerhobbies.com and click on the support or resources tab for this product.

Meaning of Special Language

The following terms are used throughout the product literature to indicate various levels of potential harm when operating this product:

WARNING: Procedures, which if not properly followed, create the probability of property damage, collateral damage, and serious injury OR create a high probability of superficial injury.

CAUTION: Procedures, which if not properly followed, create the probability of physical property damage AND a possibility of serious injury.

NOTICE: Procedures, which if not properly followed, create a possibility of physical property damage AND a little or no possibility of injury.



WARNING: Read the ENTIRE instruction manual to become familiar with the features of the product before operating. Failure to operate the product correctly can result in damage to the product, personal property and cause serious injury.

This is a sophisticated hobby product. It must be operated with caution and common sense and requires some basic mechanical ability. Failure to operate this Product in a safe and responsible manner could result in injury or damage to the product or other property. This product is not intended for use by children without direct adult supervision. Do not use with incompatible components or alter this product in any way outside of the instructions provided by Horizon Hobby, LLC. This manual contains instructions for safety, operation and maintenance. It is essential to read and follow all the instructions and warnings in the manual, prior to assembly, setup or use, in order to operate correctly and avoid damage or serious injury.

Age Recommendation: Not for children under 14 years. This is not a toy.

Safety Precautions and Warnings

- Always keep a safe distance in all directions around your model to avoid collisions or injury. This model is controlled by a radio signal subject to interference from many sources outside your control. Interference can cause momentary loss of control.
- Always operate your model in open spaces away from full-size vehicles, traffic and people.
- Always carefully follow the directions and warnings for this and any optional support equipment (chargers, rechargeable battery packs, etc.).
- Always keep all chemicals, small parts and anything electrical out of the reach of children.
- Always avoid water exposure to all equipment not specifically designed and protected for this purpose. Moisture causes damage to electronics.
- Always engage throttle hold before approaching the aircraft.
- Never place any portion of the model in your mouth as it could cause serious injury or even death.
- Never operate your model with low transmitter batteries.
- Always keep aircraft in sight and under control.
- Always move the throttle fully down at rotor strike.
- Always use fully charged batteries.
- Always keep transmitter powered on while aircraft is powered.
- Always remove batteries before disassembly.
- Always keep moving parts clean.
- Always keep parts dry.
- Always let parts cool after use before touching.
- Always remove batteries after use.
- Never operate aircraft with damaged wiring.
- Never touch moving parts.



WARNING AGAINST COUNTERFEIT PRODUCTS: If you ever need to replace a Spektrum component found in a Horizon Hobby product, always purchase from Horizon Hobby, LLC or a Horizon Hobby authorized dealer to ensure authentic high-quality Spektrum product. Horizon Hobby, LLC disclaims all support and warranty with regards, but not limited to, compatibility and performance of counterfeit products or products claiming compatibility with DSM or Spektrum technology.

Table of Contents

NX and DX Series Transmitter Setup.....	4	Advanced Tuning (Forward Programming)	11
iX Series Transmitter Setup	5	Troubleshooting Guide.....	13
Installing the Flight Battery.....	6	Limited Warranty.....	14
Smart Throttle	7	Warranty and Service Contact Information.....	14
Throttle Hold	7	FCC and Canada Compliance Information.....	15
Control Tests	8	IC Information	15
Low Voltage Cutoff (LVC)	9	Compliance Information for the European Union.....	15
Understanding the Primary Flight Controls.....	9	Exploded View	56
Pre-Flight Checklist	10	Parts List	58
Flying the Blade Eclipse 360 Helicopter.....	10	Optional Parts	59
Removing the Mechanics From the Fuselage	10	Recommended Components	59
Post-Flight Inspections and Maintenance	11		

Specifications

Length	30.6 in (767mm)	Tail Rotor Diameter	4.7 in (120 mm)
Height	7.6 in (193mm)	Flying Weight	33 oz (935 g)
Main Rotor Diameter	30.6 in (767mm)		

Components

BNF- Basic (BLH01250)

Airframe	Blade Eclipse 360	Included
Main Motor	Main Motor: Eclipse 360, (BLH01247)	Installed
Tail Motor	Tailmotor: Eclipse 360 (BLH01248)	Installed
Receiver	SRXL2 DSMX Remote Serial Telemetry Receiver	Installed
Flight Controller	FC6250HX Helicopter Flybarless Flight Control (SPMFC6250HX)	Installed
ESC	Dual ESC 30A 15A: Eclipse 360 (SPMXAHE3015)	Installed
Swash Servos	Spektrum H3050 Mid-Torq Ultra-Speed Micro Heli Cyclic Servo	Installed

Required Equipment

Transmitter	DSM2®/DSMX® Compatible Transmitter
Flight Battery	3S 11.1V 2200mAh – 3200mAh Smart 30C (or higher) Li-Po with IC3® (we recommend SPMX22003S30)
Battery Charger	3S LiPo Battery Compatible (we recommend SPMXC2050)

Optional Accessories

RFL1205	RealFlight Trainer Edition RC Flight Simulator
SPMWS2000	WS2000 Wireless Simulator USB Dongle
SPMXPSA200	Smart G2 Powerstage: 3S 2200mAh

Completion Guide

Scan the QR code to go to the product completion guide for information on the recommended Powerstage bundle as well as other compatible batteries and chargers.



First Flight Preparation

- Remove and inspect contents
- Begin charging the flight battery
- Install the flight battery in the helicopter (once it has been fully charged)
- Program your computer transmitter
- Bind your transmitter
- Program Smart telemetry options in your transmitter
- Familiarize yourself with the controls
- Find a suitable area for flying

Flying Checklist

- Always turn the transmitter on first
- Plug the flight battery into the lead from the ESC
- Allow the ESC to initialize and arm properly
- Fly the model
- Land the model
- Unplug the flight battery from the ESC
- Always turn the transmitter off last

NX and DX Series Transmitter Setup

1. Power ON your transmitter, click on scroll wheel, roll to System Setup and click the scroll wheel. Choose yes.
2. Go to Model Select and choose <Add New Model> at the bottom of the list. The system asks if you want to create a new model, select Create
3. Set Model Type: Select Helicopter Model Type by choosing the Helicopter. The system asks you to confirm model type, data will be reset. Select YES
4. Scroll down and select Model Name: Input a name for your model file
5. Scroll up to BACK and press the scroll wheel to return to System Setup
6. Scroll down and select F-Mode Setup
Set to:
Switch 1: Switch B
Hold Switch: Switch H
7. Scroll up to LIST and press the scroll wheel to return to System Setup
8. Scroll down and select Channel Assign
Scroll down on the Channel input config screen and set Ch 5 Gear to F-Mode
9. Scroll up to LIST and press the scroll wheel to return to System Setup
10. Select <Main Screen>, Click the scroll wheel to enter the Function List
11. Scroll down to Rates and Expo and press the scroll wheel
Scroll down to Channel and select Aileron
Set Switch: Switch F
Move Switch F to the 0 position
Set High Rates: 100%/100%, Expo 25%/25%
Move Switch F to the 1 position
Set High Rates: 100%/100%, Expo 25%/25%
Move Switch F to the 2 position
Set Low Rates: 75%/75%, Expo 25%/25%
12. Scroll up to Channel and select Elevator
Set Switch: Switch F
Move Switch C to the 0 position
Set High Rates: 100%/100%, Expo 25%/25%
Move Switch C to the 1 position
Set High Rates: 100%/100%, Expo 25%/25%
Move Switch C to the 2 position
Set Low Rates: 75%/75%, Expo 25%/25%
13. Scroll up to Channel and select Rudder
Set Switch: Switch F
Move Switch C to the 0 position
Set High Rates: 100%/100%, Expo 45%/45%
Move Switch C to the 1 position
Set High Rates: 100%/100%, Expo 45%/45%
Move Switch C to the 2 position
Set Low Rates: 75%/75%, Expo 45%/45%
14. Scroll up to LIST and press the scroll wheel to return to the Function List
15. Scroll down to Throttle Curve and press the scroll wheel
Scroll to the N box for curve selection and press the scroll wheel to select the Normal curve
Set the Curve values to

1	2	3	4	5
0	50	63	75	90
16. Scroll to the #1 box for curve selection and press the scroll wheel to select the Stunt #1 curve
Set the Curve values to

1	2	3	4	5
90	90	90	90	90
17. Scroll to the #2 box for curve selection and press the scroll wheel to select the Stunt #2 curve
Set the Curve values to

1	2	3	4	5
100	100	100	100	100
18. Scroll to the H box for curve selection and press the scroll wheel to select the Hold curve
Set the Curve values to

1	2	3	4	5
0	0	0	0	0
19. Scroll up to LIST and press the scroll wheel to return to the Function List

20. Scroll down to Pitch curve and press the scroll wheel
Scroll to the N box for curve selection and press the scroll wheel to select the Normal curve
Set the Curve values to

1	2	3	4	5
30	40	50	75	100
21. Scroll to the #1 box for curve selection and press the scroll wheel to select the Stunt #1 curve
Set the Curve values to

1	2	3	4	5
0	25	50	75	100
22. Scroll to the #2 box for curve selection and press the scroll wheel to select the Stunt #2 curve
Set the Curve values to

1	2	3	4	5
0	25	50	75	100
23. Scroll to the H box for curve selection and press the scroll wheel to select the Hold curve
Set the Curve values to

1	2	3	4	5
30	40	50	75	100
24. Scroll up to LIST and press the scroll wheel to return to the Function List
25. Scroll down to Mixing and press the scroll wheel
Select Mix 1, Select Normal
Select the first INH (for master) and select the I switch
Select the second INH (for slave) and select the Gear Channel
Set the first Rate value to 0% the second to -125%
Set the Offset to 100
Set the Switch to the I button
26. Scroll up to LIST and press the scroll wheel to return to the Function List
27. Scroll down to Timer and press the scroll wheel
Set to;
Mode: Count Down
Time: 5:00
Start: Throttle Out
Over: 25%
One Time: Inhibit
28. Scroll up to LIST and press the scroll wheel to return to the Function List
29. Scroll up to <Main Screen> and press the scroll wheel

See the Smart Throttle section for information on telemetry setup

iX Series Transmitter Setup

1. Power ON your transmitter and begin once the Spektrum Airware app is open.
Select the orange pen icon in the upper left corner of the screen, the system asks for permission to Turn Off RF, select PROCEED

2. Select the three dots in the upper right corner of the screen, select Add a New Model

3. Select Model Option, choose DEFAULT, select Helicopter.
The system asks if you want to create a new heli model, select Create

4. Select the last model on the list, named Heli.
Tap on the word Acro and rename the file to a name of your choice

5. Tap and hold the back arrow icon in the upper left corner of the screen to return to the main screen

6. Tap on the Model Setup button

7. Set Flight Mode Setup
Switch 1: Switch B
Hold Switch: Switch H
Tap on the arrow in the upper left corner to return to the Model Setup menu

8. Set Channel Assign
Set Channel input config: set Ch 5 Gear to Flight Mode
Tap on the arrow in the upper left corner to return to the Model Setup menu
Tap on the arrow in the upper left corner to return to the main screen

9. Tap on the Model Adjust button

10. Tap on Dual Rates and Exponential;
Tap on the pull down tab at Channel and select Aileron
Set Switch: Switch F
Move Switch F to the 0 position
Set High Rates: 100%/100%, Expo 25%/25%
Move Switch F to the 1 position
Set High Rates: 100%/100%, Expo 25%/25%
Move Switch F to the 2 position
Set Low Rates: 75%/75%, Expo 25%/25%

11. Tap on the pull down tab at Channel and select Elevator
Set Switch: Switch F
Move Switch C to the 0 position
Set High Rates: 100%/100%, Expo 25%/25%
Move Switch C to the 1 position
Set High Rates: 100%/100%, Expo 25%/25%
Move Switch C to the 2 position
Set Low Rates: 75%/75%, Expo 25%/25%

12. Tap on the pull down tab at Channel and select Rudder
Set Switch: Switch F
Move Switch C to the 0 position
Set High Rates: 100%/100%, Expo 45%/45%
Move Switch C to the 1 position
Set High Rates: 100%/100%, Expo 45%/45%
Move Switch C to the 2 position
Set Low Rates: 75%/75%, Expo 45%/45%

13. Tap on the arrow in the upper left corner to return to the Model Adjust menu

14. Tap on Throttle curve
Ensure Switch H is set to the 0 position
Set the B switch to the 0 position to select the Normal curve
Set the Curve values to

1	2	3	4	5
0	50	63	75	90

15. Set the B switch to the 1 position to select the Stunt #1 curve
Set the Curve values to

1	2	3	4	5
90	90	90	90	90

16. Set the B switch to the 2 position to select the Stunt #2 curve
Set the Curve values to

1	2	3	4	5
100	100	100	100	100

17. Set the H switch to the 1 position to select the Hold curve
Set the Curve values to

1	2	3	4	5
0	0	0	0	0

18. Tap on the arrow in the upper left corner to return to the Model Adjust menu

19. Tap on Pitch curve
Ensure Switch H is set to the 0 position
Set the B switch to the 0 position to select the Normal curve
Set the Curve values to

1	2	3	4	5
30	40	50	75	100

20. Set the B switch to the 1 position to select the Stunt #1 curve
Set the Curve values to

1	2	3	4	5
0	25	50	75	100

21. Set the B switch to the 2 position to select the Stunt #2 curve
Set the Curve values to

1	2	3	4	5
0	25	50	75	100

22. Set the H switch to the 1 position to select the Hold curve
Set the Curve values to

1	2	3	4	5
30	40	50	75	100

23. Tap on the arrow in the upper left corner to return to the Model Adjust menu

24. Tap on Mixing
Select P-Mix 1, Select Normal
Select the first INH (for master) and select the I switch
Select the second INH (for slave) and select the Gear Channel
Set the first Rate value to 0% the second to -125%
Set the Offset to 100
Set the Switch to the I button

25. Tap on <Back> in the upper right corner to return to the Mixing menu

26. Tap on the arrow in the upper left corner to return to the Model Adjust menu

27. Tap on the arrow in the upper left corner to return to the main screen

28. Tap on the clock icon in the Timer 1 box
Set to;
Mode: Count Down
Time: 5:00
Switch: Throttle Out
Over Under Trigger: 25%
One Time: Inhibit

29. Tap on the arrow in the upper left corner to return to the main screen

See the Smart Throttle section for information on telemetry setup

Installing the Flight Battery

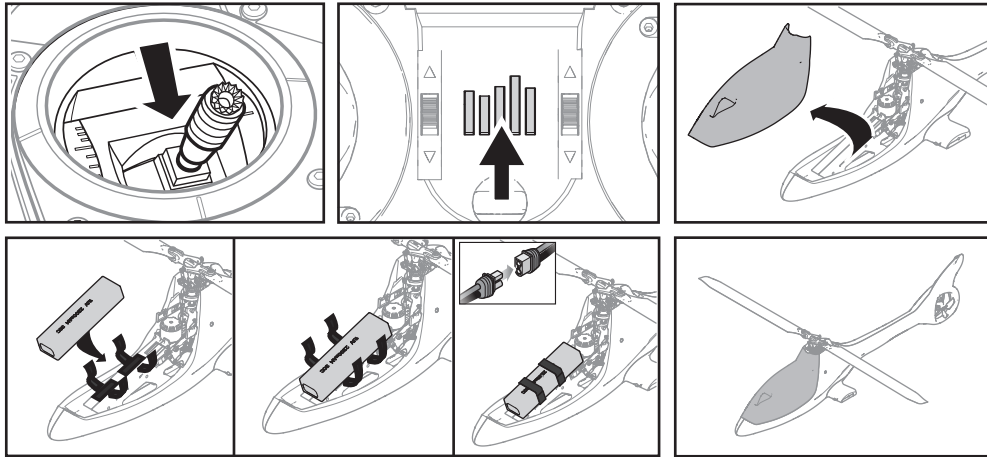

1. Lower the throttle.
2. Power on the transmitter.
3. Center all trims.
4. To allow the ESC to arm and to keep rotors from initiating at startup, turn on throttle hold and normal flight mode before connecting the flight battery.
5. Attach hook material to the helicopter frame and loop material to the battery.
6. Install the flight battery on the helicopter frame. Secure the flight battery with the hook and loop straps.
7. Bind your transmitter to the helicopter to establish a connection. See the Binding section below for more information.
8. Connect the battery cable to the ESC. The swashplate will center, indicating that the unit is ready. The flight controller status LED will display a slow green flash once initialization has been completed.
9. The helicopter motor will emit a series of tones, indicating the ESC is armed.

CAUTION: Make sure the flight battery, wire and connector does not come into contact with the motor. Failure to do so will cause the motor, ESC and battery to overheat, resulting in a crash causing property damage and injury.

CAUTION: Always disconnect the Li-Po battery from the ESC power lead when not flying to avoid over-discharging the battery. Batteries discharged below the lowest approved voltage may become damaged, resulting in loss of performance and potential fire when batteries are charged.

Transmitter and Receiver Binding

Binding is the process of programming the receiver to recognize the GUID (Globally Unique Identifier) code of a single specific transmitter. You need to 'bind' your chosen Spektrum™ DSM2®/DSMX® technology equipped aircraft transmitter to the receiver for proper operation. The receiver on the Eclipse 360 Smart helicopter is located on the bottom frame tray. The bind button is located in the center of the case, off to one side, with the Spektrum logo (bars) on the surface of the button.



Your BNF aircraft must be bound to your transmitter to establish a connection, follow the directions below.

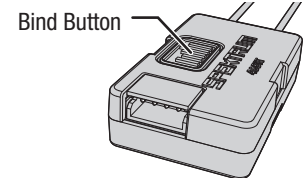

1. Program your transmitter using the Transmitter Setup found in this manual.
2. Lower the throttle stick to the lowest position, change the flight mode to normal mode (stability mode) and activate throttle hold. Set all trims to the center position.
3. Power off the transmitter, or power off the RF signal if using a Spektrum NX or iX series transmitter.
4. Connect the flight battery to the ESC.
5. Press the bind button on the remote receiver to initiate binding. The orange LED on the receiver will begin flashing rapidly to indicate bind mode.
6. Follow the procedures of your specific transmitter to enter bind mode. The system will connect within a few seconds. Once connected, the orange LED on the receiver will come on solid orange.
7. Disconnect the flight battery and power off your transmitter (or power off RF for iX series Spektrum transmitters).

If you encounter problems, obey binding instructions and refer to transmitter troubleshooting guide for other instructions. If needed, contact the appropriate Horizon Product Support office.

LED Indicator on Flight Controller

Indicator Description	
Slow Green Flash	Ready to Fly
Slow Red Flash	Failsafe Active
Slow Cyan Flash	Forward Programming Mode
Yellow Flash (during calibration)	Calibration proceeding normally
Red Flash (during calibration)	Calibration Error, FC not level or is being moved during calibration

Smart Throttle

The ESC in this helicopter paired with the FC6250HX flight controller and the 4651T receiver enables the use of Smart technology. This system can provide a variety of real-time power system related telemetry data while you fly, including motor RPM, current, battery voltage and more to compatible Spektrum AirWare™ equipped transmitters.

During binding your transmitter will perform an auto configuration which will populate the telemetry page. You may need to change the telemetry values to suit this aircraft and your needs.

To enter the telemetry values:

(For iX series transmitters, you must select Save on each page)

1. Power on your transmitter.
2. Set the throttle hold to on.
3. Power on the aircraft and allow it to initialize.

SAFE Technology

Revolutionary SAFE® (Sensor Assisted Flight Envelope) technology uses an innovative combination of multi-axis sensors and software that allows model aircraft to know its position relative to the horizon. This spatial awareness is utilized to create a controlled flight envelope the aircraft can use to maintain a safe region of bank and pitch angles so you can fly more safely. Far beyond stability, this level of protection offers multiple modes so the pilot can choose to develop his or her skills with a greater degree of security and flight control that always feels crisp and responsive.

Flight Mode and Rate Selection

Collective pitch helicopters use three powered flight modes; Normal, Stunt 1, and Stunt 2.

The Eclipse 360 has SAFE Stability On when in Normal mode. The rotor head spins at a low RPM, and the bank angle is limited. When the cyclic stick is released the model will return to level.

In Stunt 1 and Stunt 2 the Eclipse 360 has SAFE Stability Off and is only using AS3X technology to make the aircraft respond according to the control inputs. The bank angle is not limited. When the cyclic stick is released the model will not return to level.

Stunt 1 has a moderate headspeed for forward flight and sport aerobatics. Stunt 2 has a higher headspeed and can be used for more advanced aerobatics.

Flight Mode Operation

B Switch

- 0 = Normal, SAFE Stability On
- 1 = Stunt 1, SAFE Stability Off
- 2 = Stunt 2, SAFE Stability Off

Panic Recovery

If you get into distress while flying in any mode, activate the panic function and move the control sticks to their neutral position. SAFE technology will immediately return the aircraft to an upright level attitude, if the aircraft is at a sufficient height with no obstacles in its path. Return the collective stick to 50% and deactivate the Panic Recovery function to return to the current flight mode.

Panic Mode Operation

Bind / I Button

- Pressed = Panic Mode On
- Released = Panic Mode Off

Throttle Hold

Throttle hold only turns off the motor on an electric helicopter. You maintain pitch and direction control.

The blades will spin if throttle hold is OFF. For safety, turn throttle hold ON any time you need to touch the helicopter or check the direction controls.

Throttle Hold Operation

H Switch

- 0 = Motor operates normally
- 1 = Throttle hold is ON, motor will not spin

4. In your transmitter, go to the **Function List (Model Setup)** in iX series transmitters).
5. Select the **Telemetry** menu option.
6. Go to the **Smart Battery** menu option.
7. Scroll down to **Startup Volts**, enter **4.0V/cell**.
8. Return to the **Telemetry** menu.
9. Go to the **Smart ESC** menu option.
10. Scroll down to **Total Cells**, enter **3**.
11. Scroll down to **Low Voltage Alarm**, enter **3.2V/Cell** and set to **Voice**.
12. Scroll down to **Poles**, enter **8**.
13. Scroll down to **Ratio**, enter **9.64:1**
14. Return to the main screen.

SAFE technology delivers:

- Flight envelope protection you can enable at the flip of a switch.
- Multiple modes let you adapt SAFE technology to your skill level instantly.

Best of all, sophisticated SAFE technology doesn't require any work to enjoy. Every aircraft with SAFE installed is ready to use and optimized to offer the best possible flight experience.

Change control rates in any mode by moving the rate switch (Switch F).

- Low rate (switch position 2) reduces the control rates, making the model easier to control. Beginners should use low rate for initial flights.
- High rate (switch positions 0 and 1) provides full control and should be used by intermediate and experience pilots.

NOTICE: Before deactivating Panic Recovery, make sure the collective stick has been returned to the 50% position. Once the Panic Recovery has been deactivated, full negative collective becomes available, which could cause the Eclipse 360 Smart to descend rapidly.

- This mode is intended to provide the pilot with the confidence to continue to improve their flight skills.
- Move the collective stick to 50% and return all other transmitter controls to neutral for the quickest recovery.
- Once the model has reached a level upright attitude, the negative collective is reduced to prevent the user from pushing the model into the ground.

Throttle hold is also used to turn off the motor if the helicopter is out of control, in danger of crashing, or both.

Control Tests

CAUTION: You must complete the Cyclic tests prior to every flight. Failure to complete the tests and ensuring the sensor corrects in the proper direction can cause the helicopter to crash, resulting in property damage and injury.

Cyclic

It is normal for the swashplate to slowly move back to its original position after a stick input and for the servos to not move at the same speed as your control sticks.

- Tilt the helicopter forward. The swashplate must tilt backward.
- Tilt the helicopter backward. The swashplate must tilt forward.
- Roll the helicopter left. The swashplate must roll right.
- Roll the helicopter right. The swashplate must roll left.

Cyclic and Collective Control Test

Ensure the throttle hold is ON when performing the direction control tests. Test the controls prior to each flight to ensure the servos, linkages and parts

operate correctly. If the controls do not react as shown in the illustrations below, confirm the transmitter is programmed correctly before continuing on to the **Motor Test**.

Elevator/ Fore and aft cyclic

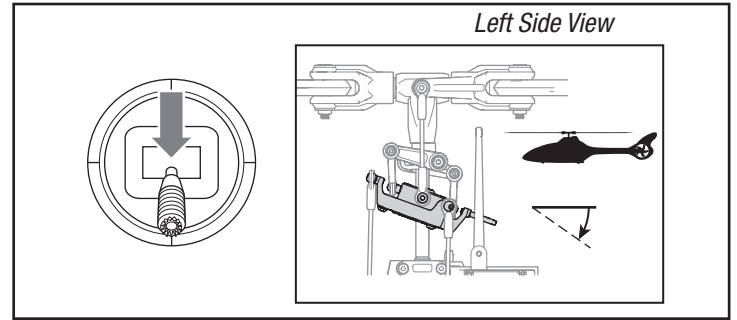
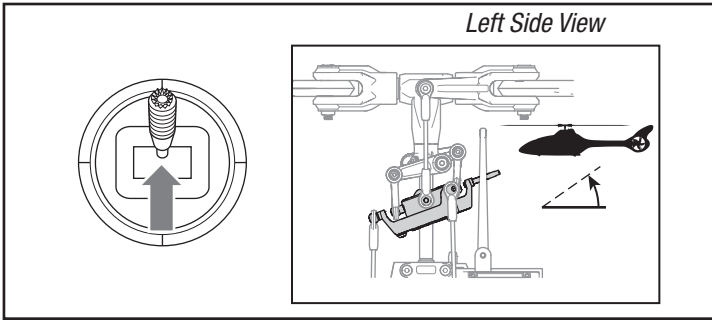

Aileron/ Left and right cyclic

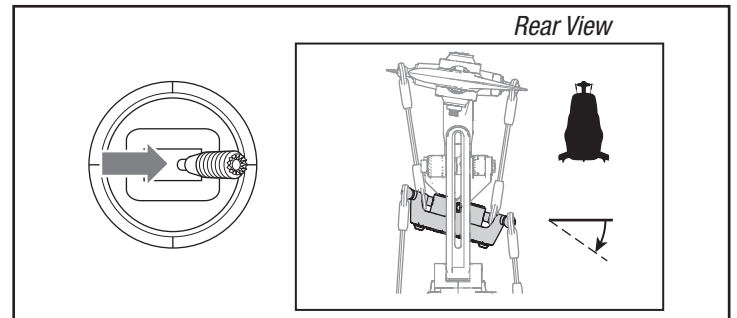
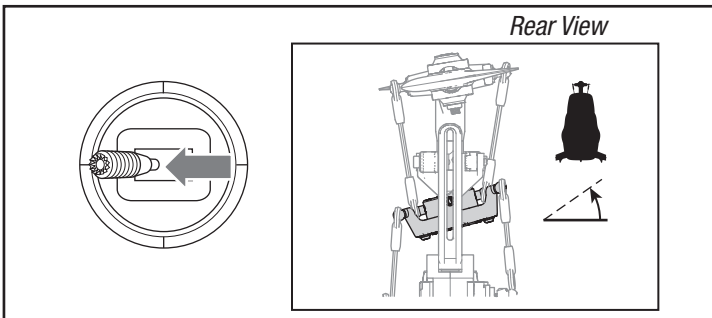

Collective Pitch

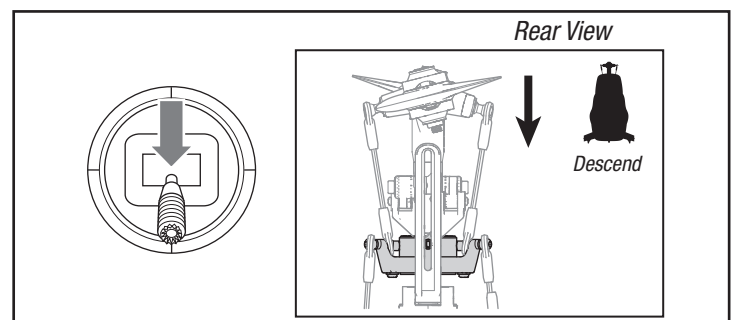
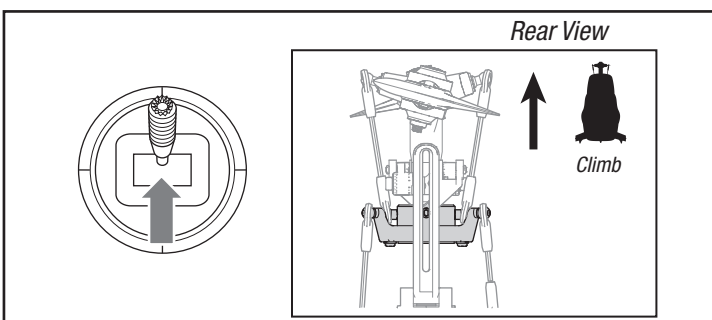

Motor Test

Place the helicopter outdoors on a clean, flat and level surface (concrete or asphalt) free of obstructions. Always stay clear of moving rotor blades.

WARNING: The motor will spin when throttle is increased while throttle hold is OFF.

1. Check the swashplate directions to ensure they are moving in the correct direction. Please refer to the diagrams on the prior page for reference.

WARNING: Stay at least 30 feet (10 meters) away from the helicopter when the motor is running. Do not attempt to fly the helicopter at this time.

2. Ensure the throttle is lowered completely and is in normal flight mode.
3. Turn throttle hold off.
4. Slowly increase the throttle until the blades begin to spin. The main blades spin clockwise when viewing the helicopter from the top. The tail rotor blades spin counterclockwise when viewing the helicopter from the right-hand side.
5. Turn throttle hold on.

Low Voltage Cutoff (LVC)

The ESC will continuously lower power to the motor until complete shutdown when the battery reaches 9V under load. This helps prevent over-discharge of the Li-Po battery. Land immediately when the ESC activates LVC. Continuing to fly after LVC can damage the battery, cause a crash or both. Crash damage and batteries damaged due to over-discharge are not covered under warranty.

Repeatedly flying the helicopter until LVC activates will damage the helicopter battery. Disconnect and remove the Li-Po battery from the aircraft after use to prevent trickle discharge. During storage, make sure the battery charge does not fall below 3V per cell.

Understanding the Primary Flight Controls

If you are not familiar with the controls of your Eclipse 360, take a few minutes to familiarize yourself with them before attempting your first flight.

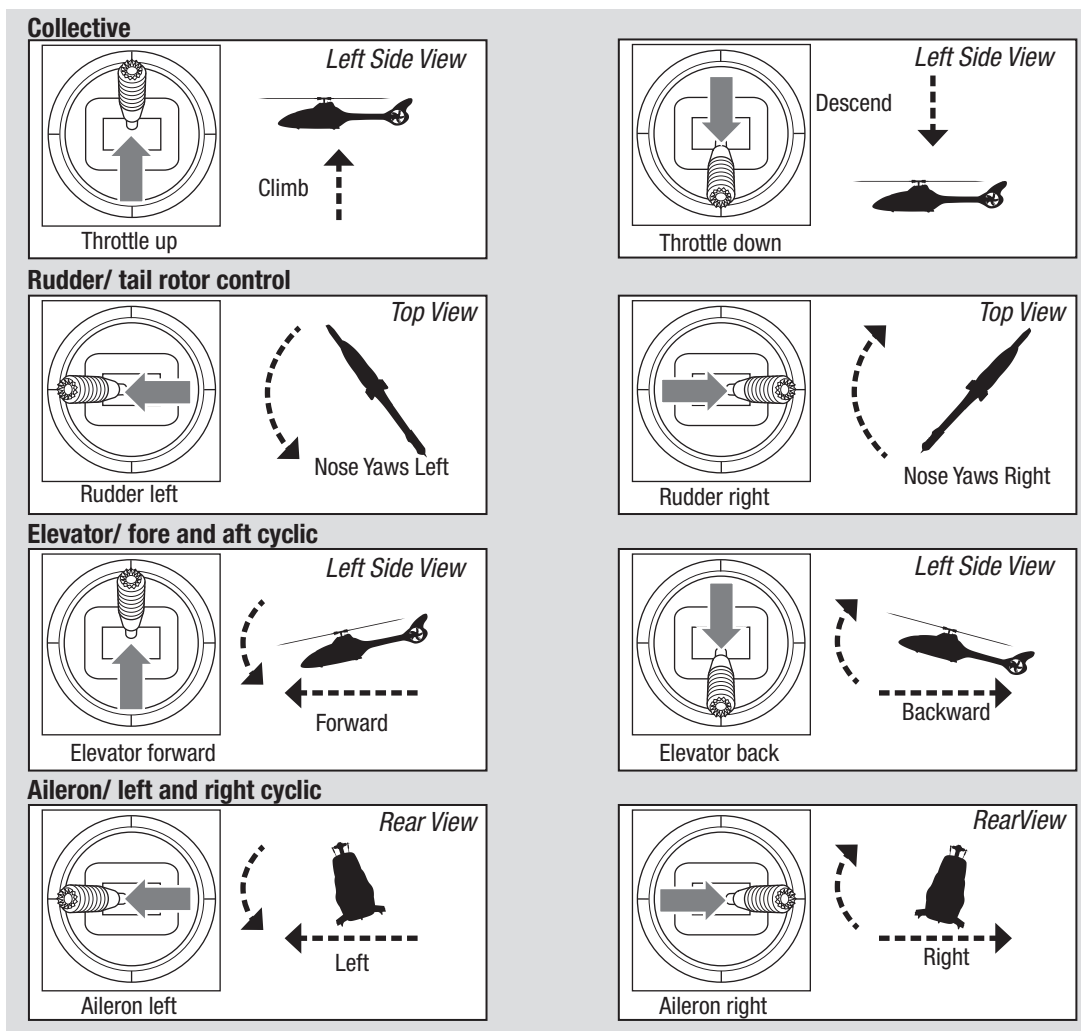

Pre-Flight Checklist

- Check all screws and ensure that they are tight
- Check main and tail blades to ensure they are not damaged
- Check all links and make sure they move freely but do not pop off easily
- Check that flight battery and transmitter battery are fully charged
- Check all wires to ensure that they are not cut, pinched, or chafed and are properly secured
- Check all wire connections
- Check gears and make sure no teeth are missing
- Do a complete control test
- Verify the receiver sensor is correcting in the proper directions
- Check that servos are functioning properly
- Check to make sure the flight battery is properly secured
- Check to make sure all electronic components are properly secured

Flying the Blade Eclipse 360 Helicopter

Consult local laws and ordinances before choosing a location to fly your aircraft.

Select a large, open area away from people and objects. Your first flights should be outdoors in low-wind conditions. Always stay at least 30 feet (10 meters) away from the helicopter when it is flying.

The Blade Eclipse 360 is intended to be flown outdoors by intermediate to experienced pilots.

Takeoff

The Eclipse 360 ESC utilizes a soft start function. Raise the throttle / collective stick to mid stick and the head speed will slowly begin to increase RPM. Once the head speed is constant (spool up takes approximately 10 seconds), raise the throttle / collective stick slowly until the model lifts off from the ground. Establish a hover at least 24" (0.6 meter) high, outside of ground effect.

CAUTION: Making large inputs to the roll or pitch controls while the helicopter is on the ground may result in a crash.

Flying

First flights should be performed in normal mode and low cyclic and tailrotor rates until you are familiar with the flying manner of the helicopter.

CAUTION: Always fly the helicopter with your back to the sun and the wind to prevent loss of flight control.

Landing

Establish a low level hover. Deliberately lower the throttle until the helicopter lands.

When the helicopter is in stunt mode:

- The rotor head speed is constant.
- The main rotor will increase negative pitch as the throttle/collective stick is moved from the middle stick position to the low stick position. Negative pitch allows the helicopter to fly upside down and perform aerobatics.

Change between normal and stunt modes in a hover with the throttle near the hovering stick position.

WARNING: Do not use wooden main blades with the Blade Eclipse 360 or injury and/or property damage could occur. Only use Blade Eclipse 360 replacement main blades.

Removing the Mechanics From the Fuselage

To remove the mechanics from the fuselage:

1. Remove the four tail motor mount screws.
2. Remove the two screws on the side of the fuselage and the six screws from the bottom of the fuselage.
3. Remove the lower hatch from the fuselage.
4. Unplug lights from wiring harness.

5. Partially remove the mechanics with tail boom from the fuselage.
6. Remove tail motor assembly from the fuselage
7. Disconnect the tail motor.
8. Complete removal of the mechanics and tail boom from the fuselage.

To reinstall the fuselage:

Repeat in reverse order.

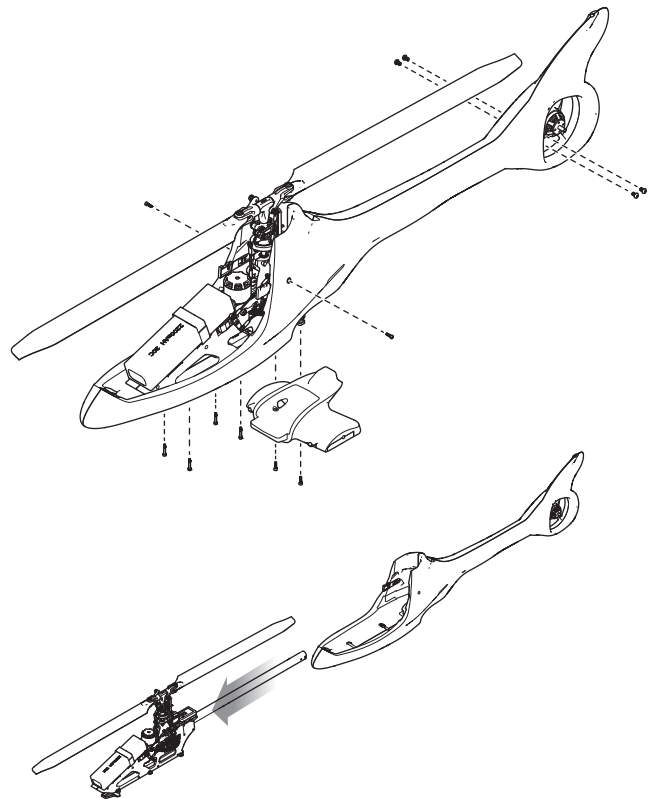

Post-Flight Inspections and Maintenance

Ball Links	Make sure the plastic ball link holds the control ball, but is not tight (binding) on the ball. When a link is too loose on the ball, it can separate from the ball during flight and cause a crash. Replace worn ball links before they fail.
Cleaning	Make sure the battery is not connected before cleaning. Remove dust and debris with a soft brush or a dry lint free cloth.
Bearings	Replace bearings when they become damaged.
Wiring	Make sure wiring does not block moving parts. Replace damaged wiring and loose connectors.
Fasteners	Make sure there are no loose screws, other fasteners or connectors. Do not over tighten metal screws in plastic parts. Tighten screw so parts are mated together, then turn screw only 1/8th of a turn more.
Rotors	Make sure there is no damage to rotor blades and other parts which move at high speed. Damage to these parts includes cracks, burrs, chips or scratches. Replace damaged parts before flying.
Flight Controller	Make sure the flight controller is securely attached to the frame. Replace the double-sided tape when necessary. The helicopter will crash if the flight controller separates from the helicopter frame.

Advanced Tuning (Forward Programming)

The following applies to forward programming capable Spektrum transmitters. Consult your transmitter manual or visit SpektrumRC.com for a complete list of forward programming capable transmitters.

The Blade Eclipse 360 default settings are appropriate for most users. We recommend flying with the default parameters before making any adjustments.

The Blade Eclipse 360 BNF flight controller may be programmed from any compatible Spektrum transmitter (visit SpektrumRC.com for more information).

The flight controller shipped with BNF models is specifically configured for the Blade Eclipse 360 Helicopter utilizing the supplied electronic components and is not intended for use in other aircraft.

Entering the Advanced Parameters Menu

With the helicopter bound to the transmitter and powered on, enter the Function List and select Forward Programming. Make small changes to one parameter at a time and test fly the changes before changing the parameter further or changing a different parameter. If at anytime you want to restore the default value for a parameter simply press the [RESET] button on IX radios screen or the [Clear] button on DX and NX transmitters and the default value for that parameter will be restored to the recommended value for your specific BNF model.

Calibration Procedure

If the helicopter is experiencing drift issues, perform the following calibration. The calibration procedure may also be needed following crash repairs.

1. Ensure the surface used for calibration is level.
2. Power on the transmitter and activate throttle hold.
3. Connect the flight batter to the ESC and allowing the model to initialize.
4. Turn Throttle Hold ON.
5. Use a small 2 axis bubble level on the motor as shown below.
6. Level the helicopter by placing a shim under the landing skid if necessary.
7. Enter the Function List on your transmitter.
8. Select Forward Programming.
9. Select System Setup.
10. Select Calibration.
11. Select Apply and the calibration will begin. The LED will flash yellow indicating the calibration is proceeding normally. If the LED changes to red this indicates the model is not near level or the model was moved, in this case the calibration starts over.
12. After the calibration is successfully completed, the receiver LED will change to a slow cyan flash which indicates the calibration has completed.
13. Exit forward programming and proceed to the pre-flight check list procedure before flying your model.

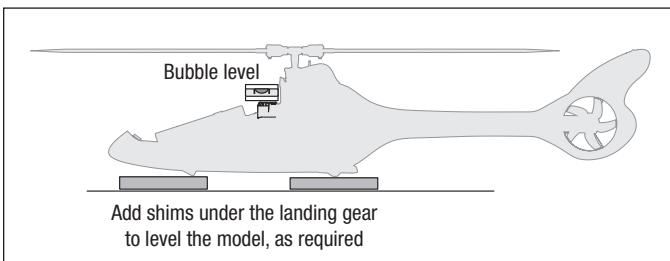
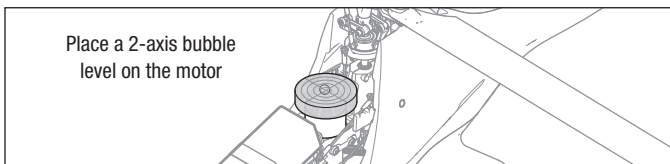

Factory Reset

If the process of changing parameters on the the Blade Eclipse 360 helicopter results in undesirable flight performance, you can reset the settings back to factory defaults by selecting the Factory Reset option in Forward Programming.

1. Enter the Function List
2. Select Forward Programming
3. Select System Setup
4. Select Factory Reset
5. Select Apply
6. Perform the Setup->Swashplate->Sub Trim function and ensure the servos are properly trimmed.
7. Proceed with the pre-flight check list procedure before flying the model.

Trim Flight

Perform this procedure if the model is not performing well or has been recently rebuilt from a crash.

The trim flight procedure was performed during the factory test flight and only needs to be performed if you notice the model is not returning to level consistently or if the model does not remain still during stationary pirouettes.

The trim flight is used to determine the optimal settings for SAFE® technology during flight.

The trim flight must be performed in calm conditions.

Entering Trim Flight Mode

1. Lower the throttle stick to the lowest position.
2. Center all trims.
3. Power ON the transmitter.
4. Install the flight battery in the helicopter.
5. Connect the battery connector to the ESC.
6. Place the helicopter on a flat surface and leave it still until the motor beeps twice and the blue ESC LED glows solid, indicating initialization is complete.
7. Place the helicopter where you are going to take off.

Performing the Trim Flight

1. Slowly increase the throttle to lift the model into a stationary hover. Make corrections as necessary to keep the model still. Evaluation does not begin until the throttle stick is over 50% and the sticks are centered. Making corrections will not affect the result but a longer flight may be necessary.
2. Keep the model stationary in a hover for 120 seconds. Sliding and slow movements are okay. The main goal is to keep the rotor disk level.
3. Once you are satisfied with the trim flight, land the model.

Exiting Trim Flight Mode

1. After landing, lower the throttle stick to the lowest position.
2. Activate Panic Recovery for 2 seconds, or until the swashplate moves, indicating the servo positions and attitude values have been recorded and trim flight mode has been exited.

8. Move and hold the left stick to the bottom left corner and the right stick to the top left corner as shown.

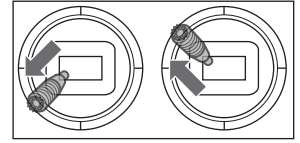

9. Activate Panic Recovery until the swashplate rotates around once.
10. Release the sticks and deactivate panic recovery.
11. The model is ready for the trim flight.

Flight Test

After performing the trim flight, test-fly the model to evaluate the leveling characteristics.

- The model should return to level flight consistently.
- During takeoff, the model should lift off with minimal corrections.
- During a hover, the control stick should remain close to center. Small corrections are acceptable.

If the model performs poorly or does not level properly after the trim flight, retry the entire trim flight procedure. If the problem persists, inspect the model for damaged components, a bent shaft or anything that may result in increased vibration. The trim flight may not record the correct values due to excessive vibration, flying in wind or the model not staying level. In these cases, shorter trim flights may be necessary. If you are still experiencing problems after several attempts please perform the calibration procedure and try the trim flight procedure again.

FC6250HX Slot Assignments

Use the following diagram if you need to replace any of the servos.

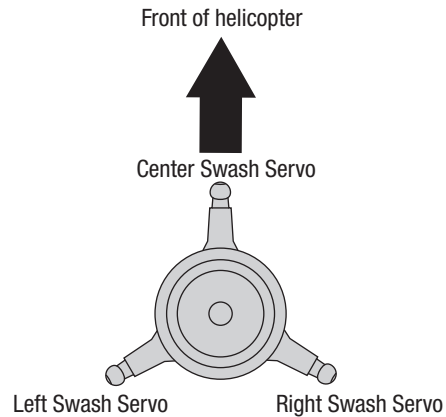
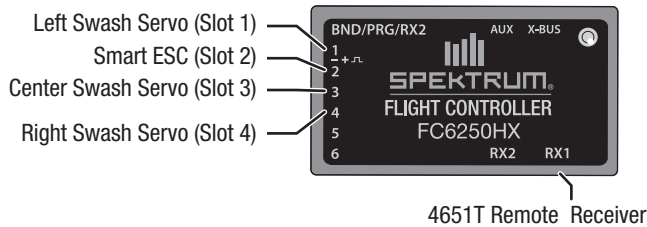

Troubleshooting Guide

Problem	Possible Cause	Solution
Helicopter will not bind to the transmitter (during binding)	Low flight battery or transmitter battery voltage	Fully charge or replace the flight battery and/or transmitter batteries
	receiver is not in bind mode	Make sure the bind plug is connected to the receiver BND/DAT port
	Transmitter is not in bind mode	Power on the transmitter while holding the Trainer/Bind switch. Hold the Trainer/Bind switch until binding is complete
	Transmitter too close to the helicopter during binding process	Power off the transmitter. Move the transmitter further away from the helicopter. Disconnect and reconnect the flight battery to the helicopter and follow binding instructions
Helicopter will not link to the transmitter (after binding)	Helicopter is bound to a different model memory (ModelMatch™ radios only)	Disconnect the flight battery. Select the correct model memory on the transmitter. Reconnect the flight battery
	Flight battery/Transmitter battery charge is too low	Replace or recharge batteries
SPMFC6250HX will not initialize	The transmitter is powered off	Power on the transmitter
	Controls are not centered	Center elevator, aileron and rudder controls. Make sure the throttle is at idle
Helicopter will not respond to the throttle but responds to other controls	Throttle not at idle and/or throttle trim is too high	Lower the throttle stick and lower the throttle trim
	The transmitter is not in normal mode or throttle hold is on	Make sure the transmitter is in normal mode and throttle hold is off
	The motor is not connected to the ESC or the motor wires are damaged	Connect the motor wires to the ESC and check motor wires for damage
	Flight battery charge is too low	Replace or recharge flight battery
	Throttle channel is reversed	Reverse the throttle channel on the transmitter
Helicopter power is lacking	Flight battery has low voltage	Fully charge the flight battery
	Flight battery is old or damaged	Replace the flight battery
	Flight battery cells are unbalanced	Fully charge the flight battery, allowing the charger time to balance the cells
	Excessive current is being drawn through the BEC	Check all servos and the helicopter motor for damage
Helicopter will not lift off	Main rotor head is not spinning in the correct direction	Make sure the main rotor head is spinning clockwise. Refer to the motor control test
	Transmitter settings are not correct	Check throttle and pitch curve settings and pitch control direction
	Flight battery has low voltage	Fully charge the flight battery
	Main rotor blades are installed backwards	Install the main rotor blades with the thicker side as the leading edge
The helicopter tail spins out of control	Rudder control and/or sensor direction reversed	Make sure the rudder control and the rudder sensor are operating in the correct direction
The helicopter wobbles in flight	Cyclic gain is too high	Please review the Advanced Settings - Gain Adjustments section
	Head speed is too low	Increase the helicopter's head speed via your transmitter settings and/or using a freshly charged flight pack
	Dampers are worn	Replace the main rotor head dampers

Limited Warranty

What this Warranty Covers—Horizon Hobby, LLC, (Horizon) warrants to the original purchaser that the product purchased (the "Product") will be free from defects in materials and workmanship at the date of purchase.

What is Not Covered—This warranty is not transferable and does not cover (i) cosmetic damage, (ii) damage due to acts of God, accident, misuse, abuse, negligence, commercial use, or due to improper use, installation, operation or maintenance, (iii) modification of or to any part of the Product, (iv) attempted service by anyone other than a Horizon Hobby authorized service center, (v) Product not purchased from an authorized Horizon dealer, (vi) Product not compliant with applicable technical regulations, or (vii) use that violates any applicable laws, rules, or regulations.

OTHER THAN THE EXPRESS WARRANTY ABOVE, HORIZON MAKES NO OTHER WARRANTY OR REPRESENTATION, AND HEREBY DISCLAIMS ANY AND ALL IMPLIED WARRANTIES, INCLUDING, WITHOUT LIMITATION, THE IMPLIED WARRANTIES OF NON-INFRINGEMENT, MERCHANTABILITY AND FITNESS FOR A PARTICULAR PURPOSE. THE PURCHASER ACKNOWLEDGES THAT THEY ALONE HAVE DETERMINED THAT THE PRODUCT WILL SUITABLY MEET THE REQUIREMENTS OF THE PURCHASER'S INTENDED USE.

Purchaser's Remedy—Horizon's sole obligation and purchaser's sole and exclusive remedy shall be that Horizon will, at its option, either (i) service, or (ii) replace, any Product determined by Horizon to be defective. Horizon reserves the right to inspect any and all Product(s) involved in a warranty claim. Service or replacement decisions are at the sole discretion of Horizon. Proof of purchase is required for all warranty claims. SERVICE OR REPLACEMENT AS PROVIDED UNDER THIS WARRANTY IS THE PURCHASER'S SOLE AND EXCLUSIVE REMEDY.

Limitation of Liability—HORIZON SHALL NOT BE LIABLE FOR SPECIAL, INDIRECT, INCIDENTAL OR CONSEQUENTIAL DAMAGES, LOSS OF PROFITS OR PRODUCTION OR COMMERCIAL LOSS IN ANY WAY, REGARDLESS OF WHETHER SUCH CLAIM IS BASED IN CONTRACT, WARRANTY, TORT, NEGLIGENCE, STRICT LIABILITY OR ANY OTHER THEORY OF LIABILITY, EVEN IF HORIZON HAS BEEN ADVISED OF THE POSSIBILITY OF SUCH DAMAGES. Further, in no event shall the liability of Horizon exceed the individual price of the Product on which liability is asserted. As Horizon has no control over use, setup, final assembly, modification or misuse, no liability shall be assumed nor accepted for any resulting damage or injury. By the act of use, setup or assembly, the user accepts all resulting liability. If you as the purchaser or user are not prepared to accept the liability associated with the use of the Product, purchaser is advised to return the Product immediately in new and unused condition to the place of purchase.

Law—These terms are governed by Illinois law (without regard to conflict of law principals). This warranty gives you specific legal rights, and you may also have other rights which vary from state to state. Horizon reserves the right to change or modify this warranty at any time without notice.

WARRANTY SERVICES

Questions, Assistance, and Services—Your local hobby store and/or place of purchase cannot provide warranty support or service. Once assembly, setup or use of the Product has been started, you must contact your local distributor or Horizon directly. This will enable Horizon to better answer your questions and service you in the event that you may need any assistance. For questions or assistance, please visit our website at www.horizonhobby.com, submit a Product Support Inquiry, or call the

toll free telephone number referenced in the Warranty and Service Contact Information section to speak with a Product Support representative.

Inspection or Services—If this Product needs to be inspected or serviced and is compliant in the country you live and use the Product in, please use the Horizon Online Service Request submission process found on our website or call Horizon to obtain a Return Merchandise Authorization (RMA) number. Pack the Product securely using a shipping carton. Please note that original boxes may be included, but are not designed to withstand the rigors of shipping without additional protection. Ship via a carrier that provides tracking and insurance for lost or damaged parcels, as Horizon is not responsible for merchandise until it arrives and is accepted at our facility. An Online Service Request is available at http://www.horizonhobby.com/content/service-center_render-service-center. If you do not have internet access, please contact Horizon Product Support to obtain a RMA number along with instructions for submitting your product for service. When calling Horizon, you will be asked to provide your complete name, street address, email address and phone number where you can be reached during business hours. When sending product into Horizon, please include your RMA number, a list of the included items, and a brief summary of the problem. A copy of your original sales receipt must be included for warranty consideration. Be sure your name, address, and RMA number are clearly written on the outside of the shipping carton.

NOTICE: Do not ship LiPo batteries to Horizon. If you have any issue with a LiPo battery, please contact the appropriate Horizon Product Support office.

Warranty Requirements—For Warranty consideration, you must include your original sales receipt verifying the proof-of-purchase date. Provided warranty conditions have been met, your Product will be serviced or replaced free of charge. Service or replacement decisions are at the sole discretion of Horizon.

Non-Warranty Service—Should your service not be covered by warranty, service will be completed and payment will be required without notification or estimate of the expense unless the expense exceeds 50% of the retail purchase cost. By submitting the item for service you are agreeing to payment of the service without notification. Service estimates are available upon request. You must include this request with your item submitted for service. Non-warranty service estimates will be billed a minimum of ½ hour of labor. In addition you will be billed for return freight. Horizon accepts money orders and cashier's checks, as well as Visa, MasterCard, American Express, and Discover cards. By submitting any item to Horizon for service, you are agreeing to Horizon's Terms and Conditions found on our website http://www.horizonhobby.com/content/service-center_render-service-center.

ATTENTION: Horizon service is limited to Product compliant in the country of use and ownership. If received, a non-compliant Product will not be serviced. Further, the sender will be responsible for arranging return shipment of the un-serviced Product, through a carrier of the sender's choice and at the sender's expense. Horizon will hold non-compliant Product for a period of 60 days from notification, after which it will be discarded.

10/15

Warranty and Service Contact Information

Country of Purchase	Horizon Hobby	Contact Information	Address
United States of America	Horizon Service Center (Repairs and Repair Requests)	servicecenter.horizonhobby.com/RequestForm/	2904 Reasearch Rd Champaign, Illinois, 61822 USA
	Horizon Product Support (Product Technical Assistance)	productsupport@horizonhobby.com 800-338-4639	
	Sales	websales@horizonhobby.com 800-338-4639	
European Union	Horizon Technischer Service Sales: Horizon Hobby GmbH	service@horizonhobby.de +49 (0) 4121 2655 100	Hanskampring 9 D 22885 Barsbüttel, Germany

*For the most up-to-date customer service contact information, please visit: www.horizonhobby.com/content/service-center-render-service-center

Important Federal Aviation Administration (FAA) Information

Use the QR code below to learn more about the Recreational UAS Safety Test (TRUST), as was introduced by the 2018 FAA Reauthorization Bill. This free test is required by the FAA for all recreational flyers in the United States. The completed certificate must be presented upon request by any FAA or law enforcement official.



If your model aircraft weights more than .55lbs or 250 grams, you are required by the FAA to register as a recreational flyer and apply your registration number to the outside of your aircraft. To learn more about registering with the FAA, use the QR code below.



FCC and Canada Compliance Information

FC FCC ID: BRWQSTLMRX2

This equipment complies with FCC and IC radiation exposure limits set forth for an uncontrolled environment. This equipment should be installed and operated with minimum distance 20cm between the radiator and/or antenna and your body (excluding fingers, hands, wrists, ankles and feet). This transmitter must not be co-located or operating in conjunction with any other antenna or transmitter.

Supplier's Declaration of Conformity

This device complies with part 15 of the FCC Rules. Operation is subject to the following two conditions: (1) This device may not cause harmful interference, and (2) this device must accept any interference received, including interference that may cause undesired operation.

CAUTION: Changes or modifications not expressly approved by the party responsible for compliance could void the user's authority to operate the equipment.

NOTE: This equipment has been tested and found to comply with the limits for a Class B digital device, pursuant to part 15 of the FCC Rules. These limits are designed to provide reasonable protection against harmful interference in a residential installation. This equipment generates, uses and can radiate radio frequency energy and, if not installed and used in accordance with the instructions, may cause harmful interference to radio communications. However, there is no guarantee that interference will not occur in a particular installation. If this equipment does cause harmful interference to radio or television reception, which can be determined by turning the equipment off and on, the user is encouraged to try

to correct the interference by one or more of the following measures:

- Reorient or relocate the receiving antenna.
- Increase the separation between the equipment and receiver.
- Connect the equipment into an outlet on a circuit different from that to which the receiver is connected.
- Consult the dealer or an experienced radio/TV technician for help.

Horizon Hobby, LLC
2904 Research Rd., Champaign, IL 61822
Email: compliance@horizonhobby.com
Web: HorizonHobby.com

IC Information

CAN ICES-3 (B)/NMB-3(B)
Contains IC: 6157A-KATY1T
IC: 6157A-QSTMRX2

This device contains license-exempt transmitter(s)/receivers(s) that comply with Innovation, Science, and Economic Development Canada's license-exempt RSS(s). Operation is subject to the following 2 conditions:

1. This device may not cause interference.
2. This device must accept any interference, including interference that may cause undesired operation of the device.

Compliance Information for the European Union

CE EU Compliance Statement:

Blade Eclipse 360 BNF Basic (BLH01250) Hereby, Horizon Hobby, LLC declares that the device is in compliance with the following: EU Radio Equipment Directive 2014/53/EU; RoHS 2 Directive 2011/65/EU; RoHS 3 Directive - Amending 2011/65/EU Annex II 2015/863.

The full text of the EU declaration of conformity is available at the following internet address: <https://www.horizonhobby.com/content/support-render-compliance>.

NOTE: This product contains batteries that are covered under the 2006/66/EC European Directive, which cannot be disposed of with normal household waste. Please follow local regulations.

Wireless Frequency Range and Wireless Output Power:

Receiver:
2402.0-2478.0MHz
18.87dBm

EU Manufacturer of Record:

Horizon Hobby, LLC
2904 Research Road
Champaign, IL 61822 USA

EU Importer of Record:

Horizon Hobby, GmbH
Hanskampring 9
22885 Barsbüttel Germany

WEEE NOTICE:



This appliance is labeled in accordance with European Directive 2012/19/EU concerning waste of electrical and electronic equipment (WEEE). This label indicates that this product should not be disposed of with household waste. It should be deposited at an appropriate facility to enable recovery and recycling.



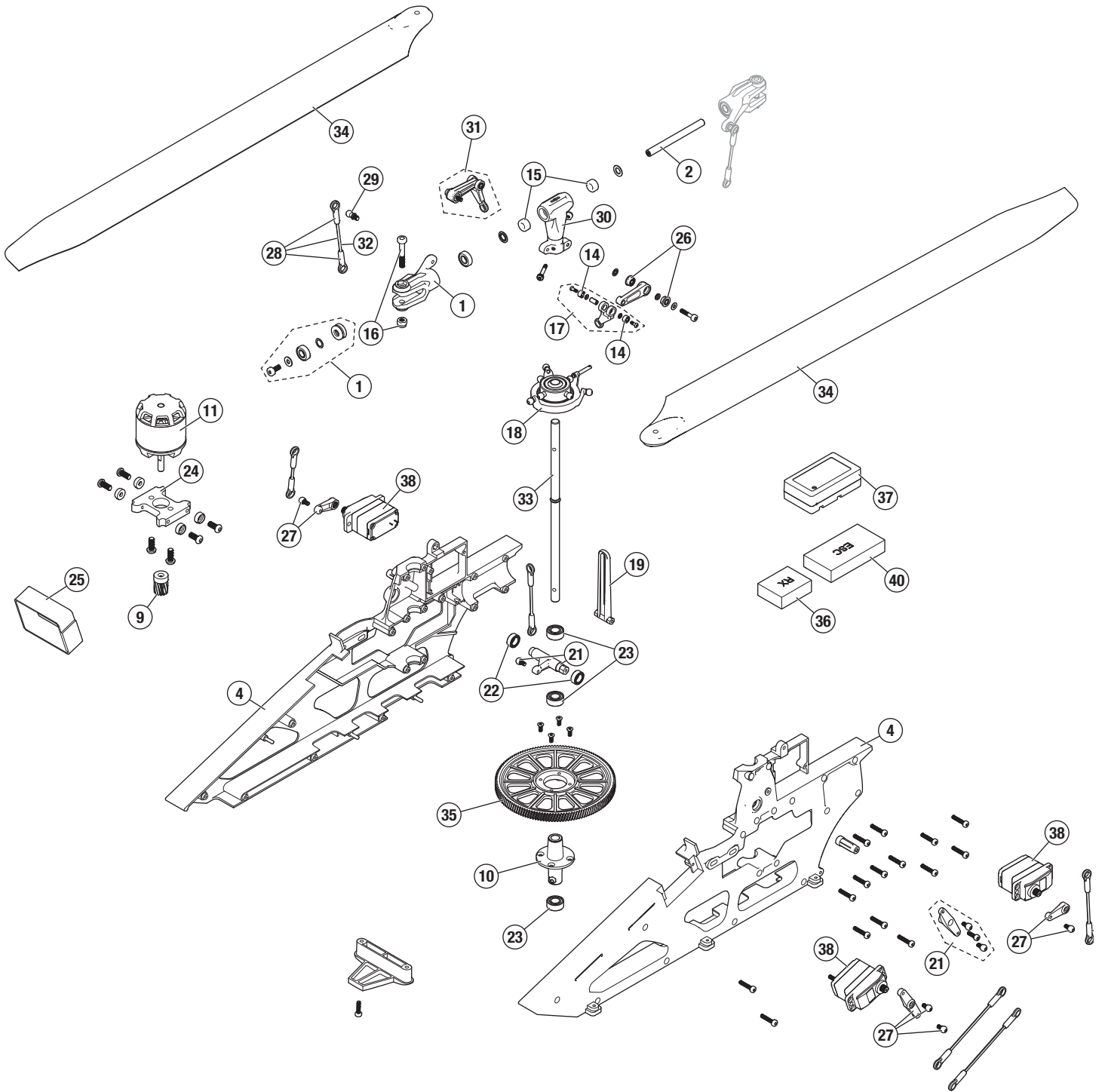

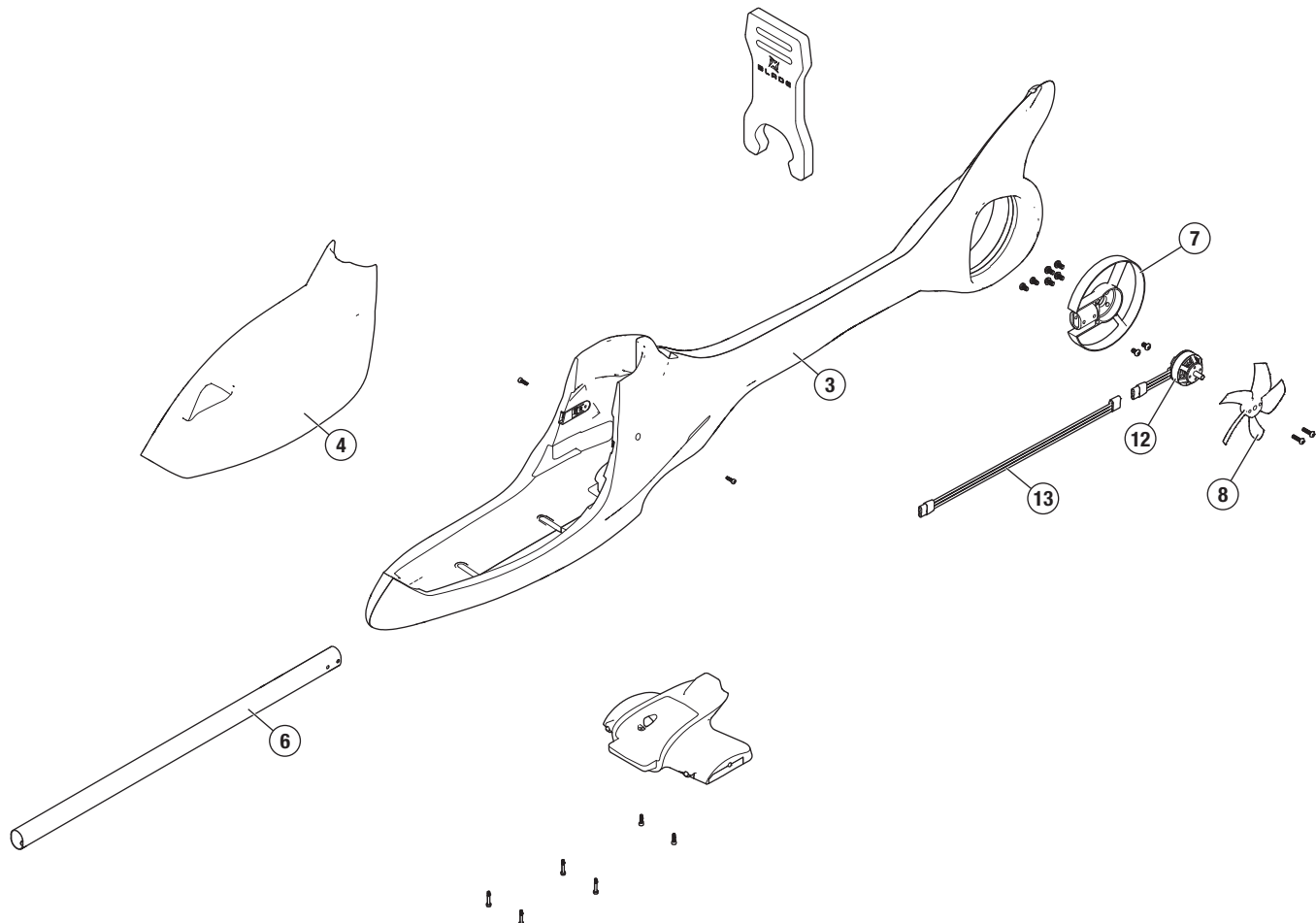

Parts List / Ersatzteile / Pièces de Rechange / Pezzi di Ricambio

#	Part #	English	Deutsch	Français	Italiano
1	BLH01201	Main Blade Grips (2): Eclipse 360	Hauptflügelblattgriffe (2): Eclipse 360	Poignées de la pale principale (2) : Eclipse 360	Impugnatura della lama principale (2): Eclipse 360
2	BLH01202	Spindle (2): Eclipse 360	Spindel (2): Eclipse 360	Axe (2) : Eclipse 360	Fusello (2): Eclipse 360
3	BLH01203	Main Body: Eclipse 360	Hauptkörper: Eclipse 360	Corps principal : Eclipse 360	Corpo principale: Eclipse 360
4	BLH01204	Main Frame: Eclipse 360	Hauptrahmen: Eclipse 360	Châssis principal : Eclipse 360	Telaio principale: Eclipse 360
5	BLH01205	Hatch: Eclipse 360	Abdeckung: Eclipse 360	Trappe : Eclipse 360	Portello: Eclipse 360
6	BLH01206	Tailboom: Eclipse 360	Heckausleger: Eclipse 360	Poutre de queue : Eclipse 360	Tube di coda: Eclipse 360
7	BLH01207	Tail Motor Mount: Eclipse 360	Heckmotorhalterung: Eclipse 360	Support moteur de queue : Eclipse 360	Supporto motore di coda: Eclipse 360
8	BLH01208	Tailrotor: Eclipse 360 (2)	Heckrotor: Eclipse 360 (2)	Rotor de queue : Eclipse 360 (2)	Rotore di coda: Eclipse 360 (2)
9	BLH01209	14t Pinon: Eclipse 360	14T Ritzel: Eclipse 360	Pignon 14t : Eclipse 360	Pignone 14t: Eclipse 360
10	BLH01210	Main Gear Housing: Eclipse 360	Hauptgetriebegehäuse: Eclipse 360	Boîtier du train principal : Eclipse 360	Alloggiamento carrello principale: Eclipse 360
11	BLH01247	Main Motor: Eclipse 360	Hauptmotor Eclipse 360	Moteur principal : Eclipse 360	Motore principale: Eclipse 360
12	BLH01248	Tailmotor: Eclipse 360	Heckmotor: Eclipse 360	Moteur de queue : Eclipse 360	Motore di coda: Eclipse 360
13	BLH01249	Tail Extension Lead: Eclipse 360	Verlängerungsleitung Heck: Eclipse 360	Rallonge de queue : Eclipse 360	Cavo di prolunga della coda: Eclipse 360
14	BLH1607	1.4x4x2 Bearing (4)	Lager 1,4x4x2 (4)	Roulembt 1,4 x 4 x 2 (4)	1.cuscinetto 4x4x2 (4)
15	BLH1608	Dampeners 80 (4): B450	Stoßdämpfer 80 (4): B450	Amortisseurs 80 (4) : B450	Ammortizzatori 80 (4): B450
16	BLH1616	Main Rotor Blade Mounting Screw & Nut (2):B450	Befestigungsschraube und Mutter Hauptrotorblatt (2):B450	Vis et écrous de support de pale du rotor principal (2) : B450	Vite e dado di montaggio della lama del rotore principale (2):B450
17	BLH1632	Washout Ctrl Arm Link Set: B450	Verbindungssatz Pitch-Steuerarm: B450	Kit de liaison de bras de commande de lavage : B450	Set di collegamenti del braccio di controllo del washout: B450
18	BLH1633	Alum & Comp Swashplt: B450, B400	Taumelscheibe, Aluminium & Verbundmaterial: B450, B400	Plateau cyclique en aluminium et composite : B450, B400	Alluminio e Comp piatto oscillante: B450, B400
19	BLH1634	Anti-RotBrckt/Guide: B450, B400	Schraubensicherung/Führung: B450, B400	Guide/support antirotation : B450, B400	Anti-RotBrckt/Guida: B450, B400
20	BLH1637	Ball Link Set (20): B450, B400	Kugelgelenk-Satz (20): B450, B400	Ensemble de liaisons à billes (20) : B450, B400	Set di collegamenti a sfera (20): B450, B400
21	BLH1640	ElevatorCtrlLeverSt: B450, B400	Höhenruder-Steuerhebelsatz: B450, B400	Ensemble de leviers de commande de profondeur : B450, B400	ElevatorCtrlLeverSt: B450, B400
22	BLH1641	5x8x2.5 Bearing (2)	Lager 5x8x2,5 (2)	Roulement 5 x 8 x 2,5 (2)	Cuscinetto 5x8x2,5 (2)
23	BLH1642	5x10x4 Bearing (2)	Lager 5x10x4 (2)	Roulement 5 x 10 x 4 (2)	Cuscinetto 5x10x4 (2)
24	BLH1643	Alum Motor Mount Set: B450, B400	Aluminium-Motorhalterungssatz: B450, B400	Ensemble support du moteur en aluminium : B450, B400	Set supporto motore alum: B450, B400
25	BLH1644	Hook&LoopBattStrap: B450, B400	Klettband Akku: B450, B400	Bande velcro pour la batterie : B450, B400	Gancio e anelloBattStrap: B450, B400
26	BLH1666	2x5x2.5 Bearing (4)	Lager 2x5x2,5 (4)	Roulement 2 x 5 x 2,5 (4)	Cuscinetto 2x5x2,5 (4)
27	BLH1676	Servo Arm Set: B450, B400	Servoarm-Satz: B450, B400	Ensemble de bras de servo : B450, B400	Set bracci servo: B450, B400
28	BLH4301	Flybarless Linkage Set: B450 X	Gestängesatz ohne Paddelstange: B450 X	Ensemble tringlerie sans barre stabilisatrice : B450 X	Set leveraggi Flybarless: B450 X
29	BLH4303	Main Rotor Grip FBL Control Balls (2):B450X	FBL-Rollkugel Hauptrotorhalter (2): B450X	Rotules de commande, poignée, rotor principal FBL (2) : B450X	Sfere di controllo FBL dell'impugnatura del rotore principale (2):B450X
30	BLH4322	Alu FBL Head Block Set: B450 X	Alu FBL Kopfblocksatz: B450 X	Ensemble bloc de tête FBL en aluminium : B450 X	Set blocco testa Alu FBL: B450 X
31	BLH4331	FBL Follower Arms: B450 X	FBL Folgerarme: B450 X	Bras suivants FBL : B450 X	FBL Bracci di scorrimento: B450 X
32	BLH4338	FBL LnkageRd/Pshrd St: B450 X	FBL Gestängesatz: B450 X	Ensemble barres/tiges de liaison : B450 X	FBL LnkageRd/Pshrd St: B450 X
33	BLH4347	Flybarless Mainshaft (2): B450 X	Hauptwelle ohne Paddelstange (2): B450 X	Arbre principal sans barre stabilisatrice (2) : B450 X	Albero principale Flybarless (2): B450 X
34	BLH5201	Fusion 350mm Main Blade	Fusion 350 mm Hauptblatt	Pale principale Fusion 350 mm	Pala principale Fusion 350 mm
35	BLH5337	Helical Main Gear, 135T	Schrägverzahntes Hauptgetriebe, 135T	Train principal hélicoïdal, 135T	Ingranaggio principale elicoidale, 135T
36	SPM4651T	SRXL2 Serial Telemetry Receiver	Serieller Telemetrieempfänger SRXL2	Récepteur de télémétrie en série SRXL2	Ricevitore telemetrico Seriale SRXL2
37	SPMFC6250HX	FC6250HX Helicopter FBL System	FC6250HX Hubschrauber mit FBL-System	Système FBL pour hélicoptère FC6250HX	Sistema per elicottero FBL FC6250HX
38	SPMSH3050	H3050 M-T / U-S MicroCyclicServ	H3050 M-T / U-S Mikro-Steuer servo	Micro servo cyclique H3050 M-T / U-S	H3050 M-T / U-S MicroCyclicServ
39	SPMSP2052	Case Set: H3050, H3060	Gehäusesatz: H3050, H3060	Ensemble de boîtier : H3050, H3060	Set custodia: H3050, H3060
40	SPMXAHE3015	Dual ESC 30A 15A: Eclipse 360	Doppel-ESC 30A 15A: Eclipse 360	Variateur ESC double 30 A 15 A : Eclipse 360	Doppio ESC 30A 15A: Eclipse 360

Optional Parts / Optionale Bauteile / Pièces Optionnelles / Pezzi Opzionali

Part #	English	Deutsch	Français	Italiano
BLH4317A	Alu FBL Main Rtr Grp Set: B450 X	Alu FBL Hauptrotorhaltersatz: B450 X	Ensemble poignée du rotor principal FBL en aluminium : B450 X	Set di gruppi di montaggio principale FBL in alluminio: B450 X
BLH4331A	Alu FBL Follower Arms: B450 X	Alu FBL Folgerarme: B450 X	Bras suiveurs FBL en aluminium : B450 X	Bracci di scorrimento Alu FBL: B450 X

Recommended Components / Empfohlene Komponenten / Composants recommandés / Componenti raccomandati

Part #	English	Deutsch	Français	Italiano
SPMX22003S100	2200mAh 3S 11.1V Smart 100C; IC3	2200 mAh 3S 11,1 V Smart 100C; IC3	2200 mAh 3S 11,1 V Smart 100C ; IC3	2200 mAh 3S 11,1 V Smart 100C; IC3
SPMX22003S30	2200mAh 3S 11.1V Smart 30C; IC3	2200 mAh 3S 11,1 V Smart 30C; IC3	2200 mAh 3S 11,1 V Smart 30C ; IC3	2200 mAh 3S 11,1 V Smart 30C; IC3
SPMX22003S50	2200mAh 3S 11.1V Smart 50C; IC3	2200 mAh 3S 11,1 V Smart 50C; IC3	2200 mAh 3S 11,1 V Smart 50C ; IC3	2200 mAh 3S 11,1 V Smart 50C; IC3
SPMXC1020	Smart S120 USB-C Charger, 1x20	Smart S120 USB-C-Ladegerät, 1 x 20 W	Chargeur Smart S120 USB-C, 1 x 20	Caricabatterie Smart S120 USB-C, 1x20 W
SPMXPSA200	Smart G2 Air Powerstage 2	Smart G2 Air Powerstage 2	Smart G2 Air Powerstage 2	Smart G2 Air Powerstage 2



©2023 Horizon Hobby, LLC.

Blade, the Blade logo, SAFE, The SAFE logo, DSM2, DSMX, BNF, the BNF logo, IC3, and the Horizon Hobby logo are trademarks or registered trademarks of Horizon Hobby, LLC.

The Spektrum trademark is used with permission of Bachmann Industries, Inc.
All other trademarks, service marks or logos are property of their respective owners.

US 9,930,567. US 10,419,970. US 10,849,013. CN201721563463.4. Other patents pending.

Created 09/23

533908

BLH01250