

Name: <u>Petr Sekula</u>		Date: <u>16.11.2013</u>	Event: <u>XRAY MORAVIA CHALLENGE</u>
City: <u>Trenčín</u>		State: <u>SK</u>	
Track: <u>Hudy arena</u>			
Track Conditions	<input checked="" type="checkbox"/> Indoor <input type="checkbox"/> Outdoor	<input checked="" type="checkbox"/> Tight <input type="checkbox"/> Open	<input checked="" type="checkbox"/> Smooth <input type="checkbox"/> Rough
	<input type="checkbox"/> Hard Packed <input type="checkbox"/> Loose/Loamy	<input type="checkbox"/> Blue Groove <input type="checkbox"/> Dry	<input type="checkbox"/> Wet <input type="checkbox"/> Dusty
	<input type="checkbox"/> Grass <input type="checkbox"/> Astro Turf	<input checked="" type="checkbox"/> Low Bite <input checked="" type="checkbox"/> Med Bite	<input checked="" type="checkbox"/> High Bite <input type="checkbox"/> Other <u>carped, wood, mix</u>

Front Suspension

Toe: 0°

Ride Height: 25mm

Camber: 2°

Caster: 0° 3° 5° 10°

Kick Angle: 20° 25° 30°

Sway Bar: No

Shock Type: Bladder Emulsion Oil: 27.5wt

Piston: reverse

Spring: blue

Shock Limiters: 3mm

Shock Location: 1 inside

Bump Steer: 0mm

Camber Link: 1 inside

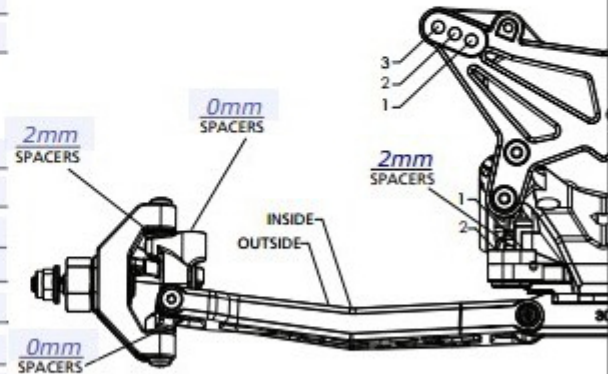

Notes: _____

Rear Suspension

Chassis Configuration: Rear Motor Mid Motor

Differential: Ball Diff Gear Diff Gear Diff Fluid: _____

Toe: 3°

Anti-Squat: 2°

Roll Center: Low Roll Center (LRC) High Roll Center (HRC)

Ride Height: 25mm

Camber: 2°

Rear Hub Spacing: middle

Hex Width: stock

Sway Bar: No

Shock Type: Bladder Emulsion Oil: 27.5wt

Piston: reverse

Spring: yellow

Shock Limiters: 3mm

Camber Link: 1 B

Shock Locations: 2 outside

Battery Position: width saddle pack

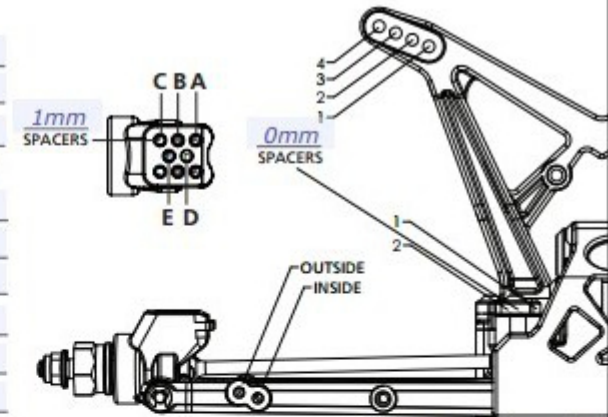

Editable by Arn0 at Pelitrc.com

Electronics

Radio: <u>Spektrum</u>	Timing Advance: _____
Servo: <u>BluebirdBMS631MG</u>	Throttle/Brake Expo: <u>100%</u>
ESC: <u>LRP sphere competition</u>	Servo Expo: _____
Initial Brake: <u>0</u>	Throttle/Brake EPA: <u>100%</u>
Drag Brake: <u>0</u>	Motor: <u>LRP VECTOR X11 10.5Z</u>
Throttle Profile: <u>6</u>	Pinion: <u>18</u> Spur: <u>84</u>
	Battery: <u>Turnigy 4850mAh</u>

Weight Placement
(Mark with "X")

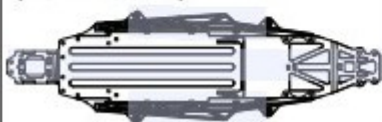

Weight of each piece _____ oz./g

Tires	Compound	Insert	Additive
Front: <u>Schumacher</u>	<u>yellow</u>	<u>yellow</u>	<u>No</u>
Rear: <u>Schumacher</u>	<u>yellow</u>	<u>yellow</u>	<u>No</u>

Notes: _____